

**Marking out for angular outlines, filing and fitting the inserts into gaps**

**Objectives:** At the end of this exercise you shall be able to

- mark an angular out lines on part A & B with an accuracy of  $\pm 0.02\text{mm}$
- file part A & B maintain the accuracy of H7/g6 for fitting
- fit inserts.

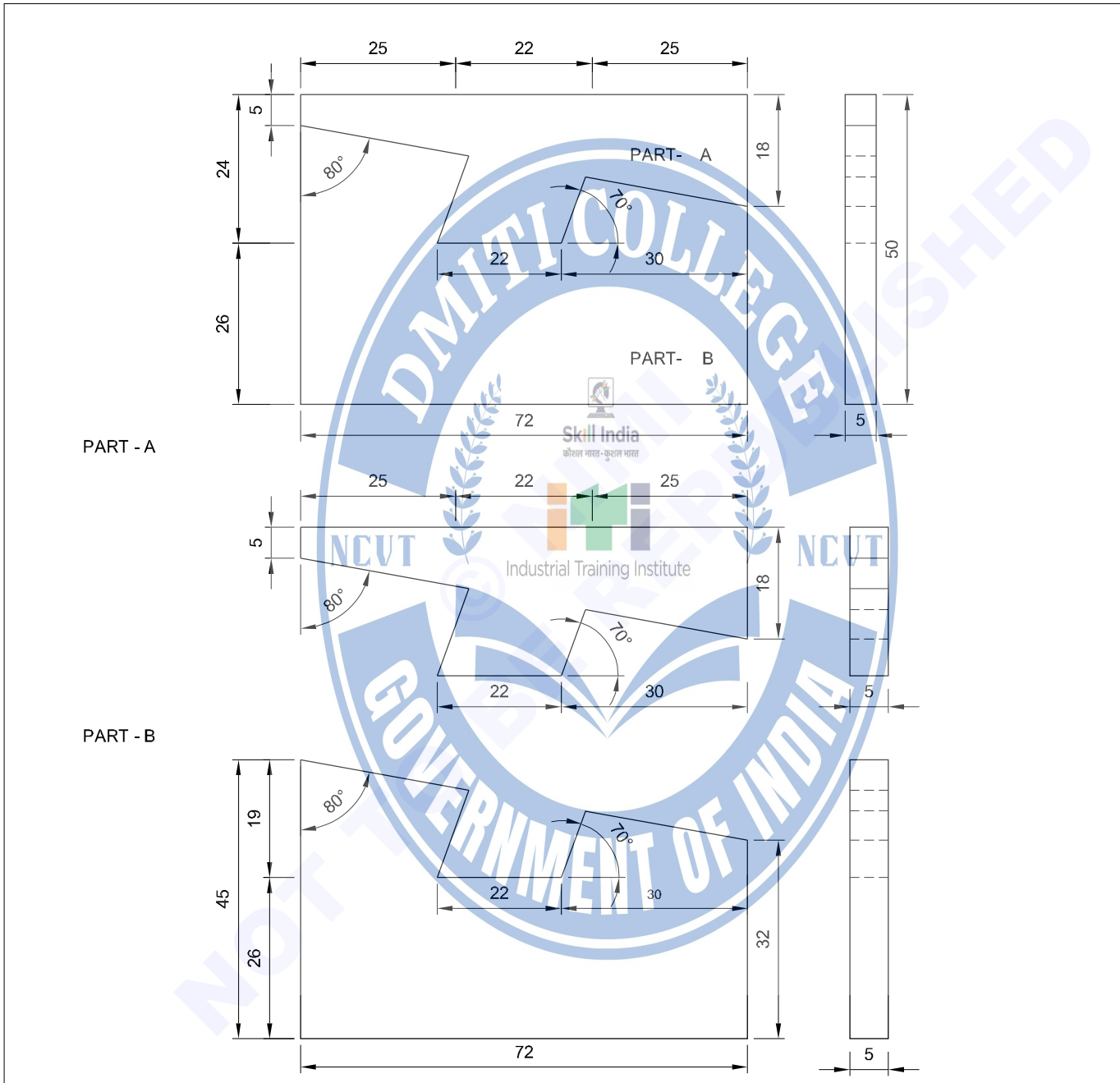

1	75 ISF 6 - 50	-	Fe310	-	B	2.5.159
1	75 ISF 6 - 28	-	Fe310	-	A	
NO.OFF	STOCK SIZE	SEMI-PRODUCT	MATERIAL	PROJECT NO.	PART NO.	EX. NO.
SCALE 1:1					TOLERANCE $\pm 0.02\text{ mm}$ TIME : 6 Hrs	
<p align="center"><b>MARKING OUT FOR ANGULAR OUTLINES, FILING AND FITTING THE INSERTS INTO GAPS</b></p>					CODE NO. FI20N25159E1	

## Job sequence

- Cut the raw materials as per the dimensions
- File right angle and mark off part A & B with vernier height gauge and vernier bevel protractor
- Punch on the marked lines / out lines
- Remove unwanted materials by hacksawing and chain drilling
- File Part A&B with a linear accuracy of  $\pm 0.02\text{mm}$  and angular of  $\pm 5'$
- Checking the angular dimensions by vernier bevel protractor
- Fit Part : A & B and finish

### **Safety**

- Do not mark angular dimensions / angle by scale / set square while marking
- Do not use hammer for fitting



**Exercises on finished material, such as aluminium/ brass/ copper/ stainless steel, marking out, cutting to size, drilling, tapping etc. without damage to surface of finished articles**

**Objectives:** At the end of this exercise you shall be able to

- mark on the Aluminium, Brass, Copper with vernier height gauge
- cut extra metal using hacksaw
- drill counter sink, counter bore and ream
- tap, finish and de- burr.

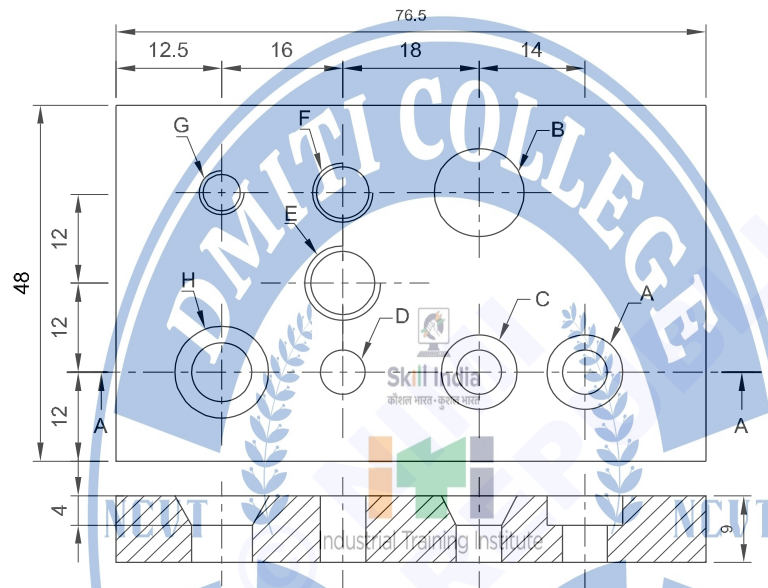

NOTE: COMMON JOB DRAWING FOR TASK 1 TO 4

- |                  |   |     |                  |   |       |
|------------------|---|-----|------------------|---|-------|
| A - Counter Bore | - | ∅ 6 | F - Tap          | - | M8    |
| B - Drilling     | - | ∅12 | G - Tap          | - | M6    |
| C - Counter Sunk | - | ∅10 | H - Counter Sunk | - | ∅12.5 |
| D - Ream         | - | ∅ 6 |                  |   |       |
| E - Tap          | - | M10 |                  |   |       |

1	75 ISF 10-52	-	STAINLESS STEEL	4	-	2.5.160
1	75 ISF 10-52	-	COPPER	3	-	2.5.160
1	75 ISF 10-52	-	BRASS	2	-	2.5.160
1	75 ISF 10-52	-	ALUMINIUM	1	-	2.5.160
NO.OFF	STOCK SIZE	SEMI-PRODUCT	MATERIAL	TASK	PART NO.	EX. NO.

SCALE : NTS	<b>EXERCISES ON FINISHED MATERIALS, SUCH AS ALUMINIUM/BRASS/ COPPER/STAINLESS STEEL, MARKING OUT, CUTTING TO SIZE, DRILLING, TAPPING ETC. WITHOUT DAMAGE TO SURFACE OF FINISHED ARTICLES</b>	TOLERANCE ±0.02 mm	TIME : 9 Hrs
		CODE NO. FI20N25160E1	

## Job sequence

### Task 1 to 4

- Check the raw material.
- File adjacent sides and one flat surface.
- Mark the dimensions as per drawing.
- Punch on marked dimension with 'Dot punch' and centre punch.
- Set the job on drilling machine.
- Make the drill holes as per drawing.
- Use kerosene as coolant for task-1 Aluminium.
- Use dry soluble oil or lard oil as coolant for task-2 - Brass.
- Use dry soluble oil or mineral lard oil as coolant for task-3 - Copper.
- Use cutting fluid as coolant for task - 4 stainless steel.
- Make reaming, counter boring, tapping and counter sinking as per dimensions
- Remove burrs and submit work for evaluation.

#### Caution

**Use soft jaw for clamping on the vice use only soft hammer for setting the work piece.**

**Do not over tight the work piece, handle gently not ot make any scratch on the work piece.**



**Making an adjustable spanner**

**Objectives:** At the end of this exercise you shall be able to

- prepare different parts referring to the drawing
- prepare for assembly
- assemble all the parts
- check for the accuracy.

The drawing shows the assembly of an adjustable spanner. Part A is the fixed jaw, Part B is the sliding jaw, Part C is a special screw, Part D is a sliding plate, Part E is a knurled nut, Part F is a flat CSK head rivet, and Part G is a cylindrical pin. Dimensions include a total length of 82.5 mm, a jaw width of 6 mm, and various radii (R3, R5, R2). A tolerance of  $\pm 0.02$  mm is specified for the assembly.

NO.OFF	STOCK SIZE	DESCRIPTION	MATERIAL	PROJECT NO.	PART NO.	EX. NO.
1	$\text{Ø}2\text{h}8 \times 10$ IS : 2393	CYLINDRICAL PIN	Fe310		G	
2	$\text{Ø}4 \times 18$ IS : 2155	FLAT CSK HEAD RIVET	Fe310		F	
1	$\text{Ø}18 - 18$	KNURLED NUT	Fe310		E	
1	ISST 125 x 1.6 - 55	SLIDING PLATE	Fe310		D	
1	$\text{Ø}6 - 58$	SPECIAL SCREW	Fe310		C	
1	30 ISF 8 - 70	SLIDING JAW	Fe310		B	
1	40 ISF 8 - 85	FIXED JAW	Fe310		A	2.5.161
NO.OFF	STOCK SIZE	DESCRIPTION	MATERIAL	PROJECT NO.	PART NO.	EX. NO.

SCALE 1:1

**MAKING AN ADJUSTABLE SPANNER**

TOLERANCE  $\pm 0.02$  mm TIME : 16 Hrs

CODE NO. FI20N25161E1

PART - B SLIDING JAW

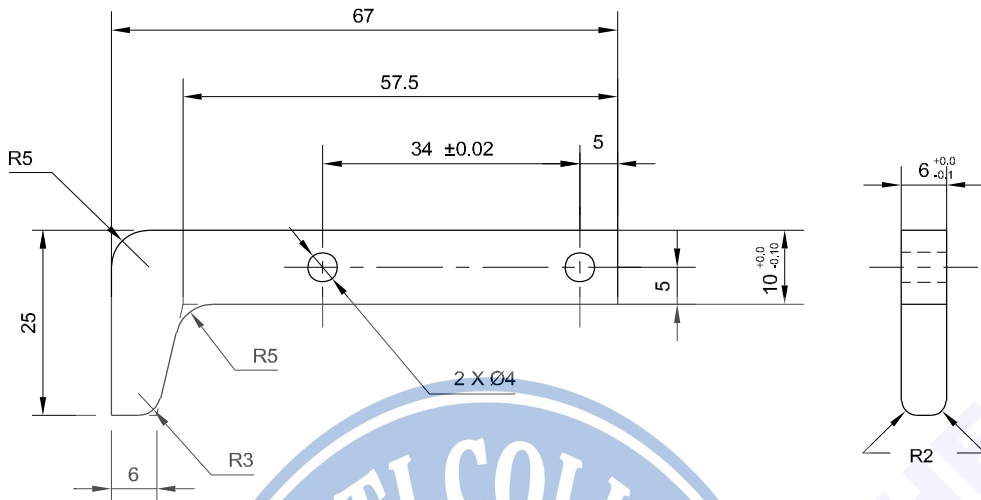

PART - C SPECIAL SCREW

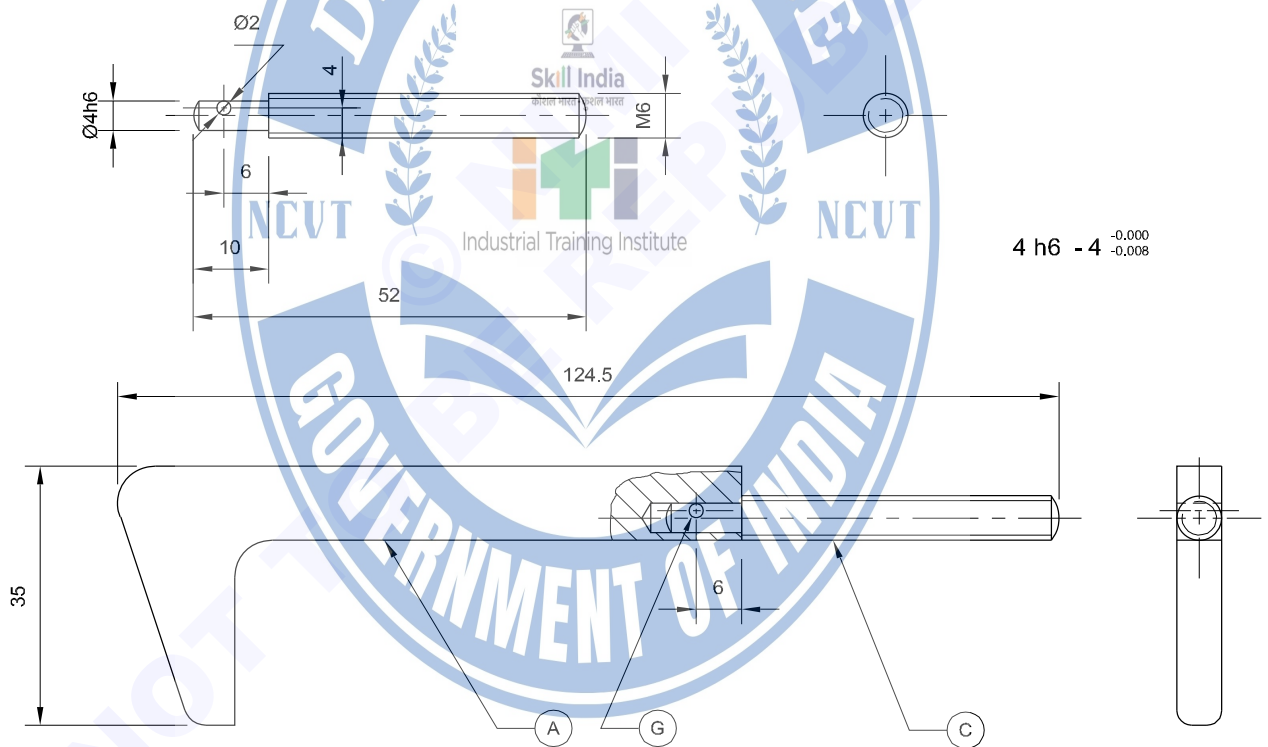

SPECIAL SCREW ASSEMBLED WITH FIXED JAW

-	-	-	-	-	A & B	2.5.161
NO.OFF	STOCK SIZE	SEMI-PRODUCT	MATERIAL	PROJECT NO.	PART NO.	EX. NO.
SCALE 1:1	<b>PARTS OF ADJUSTABLE SPANNER</b>				TOLERANCE ±	TIME:
					CODE NO. F120N25161E2	

PART - D SLIDING PLATE

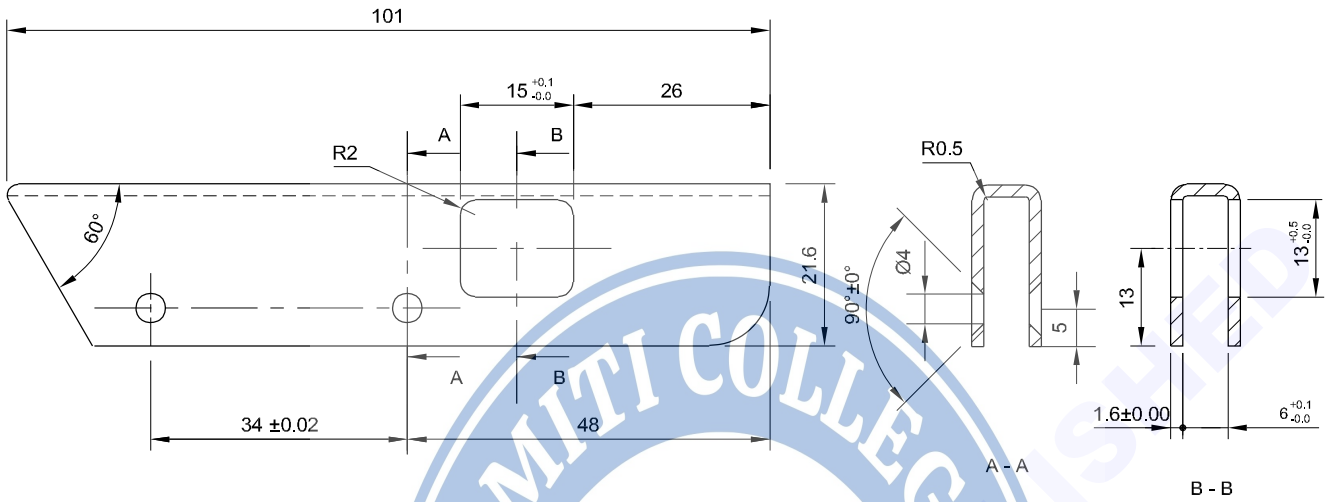

PART - E KNURLED NUT

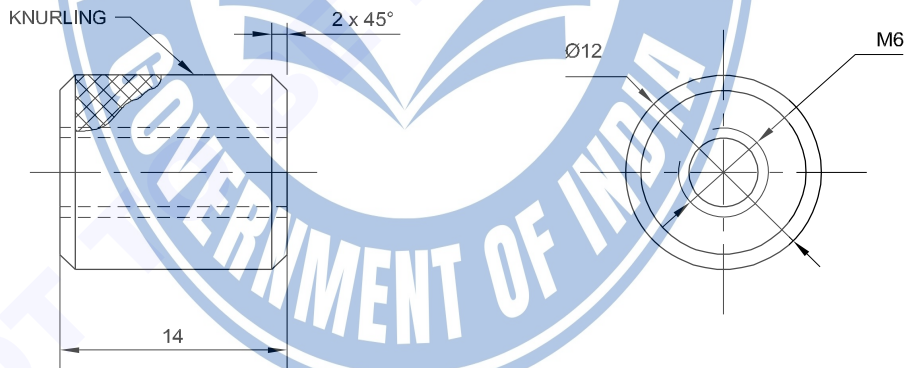

-	-	-	-	-	C	2.5.161
NO.OFF	STOCK SIZE	SEMI-PRODUCT	MATERIAL	PROJECT NO.	PART NO.	EX. NO.
SCALE 1:1	<b>PARTS OF ADJUSTABLE SPANNER</b>				TOLERANCE ±	TIME:
					CODE NO. F120N25161E3	

## Job sequence

### TASK 1:

#### Part 'A' - Fixed jaw

- Check the raw material for the given size
- File the surface and side for straightness
- File the adjacent side for right angle
- Do the marking as per drawing with vernier height gauge
- Remove the excess material by hacksawing or chain drilling
- Drill  $\varnothing 10$  hole for the R5 concave
- File and check for the dimension as per drawing
- Check the radius with radius gauge R5 & R3
- Drill the hole  $\varnothing 3.8$  mm from the side to the depth of 12mm and ream  $\varnothing 4$
- De - burr and finish smooth surface

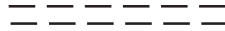

### TASK 2:

#### Part 'B' - sliding jaw

- Check the raw material for the given size
- File the surface and side for straightness
- File the adjacent side for right angle
- Mark the job as per the drawing with vernier height gauge
- Remove the excess material by hacksawing or chain drilling and  $\varnothing 4$ , 2 hole
- File the job for the dimension and check the dimension
- File for the radius edges
- File the edges and deburr the job

### TASK 3:

#### Part - 'C' - Special screw

- Check the rod for  $\varnothing 6 \times 52$  mm
- Turn the rod holding in 3 jaw chuck for  $\varnothing 4$ mm, 10mm length with h6 finish.
- Reduce length to 52mm.
- Do the threading M6 for the entire length
- Check with the die nut for threaded portion
- Insert the rod into the fixed jaw and position it.
- Drill  $\varnothing 2$ mm hole along with the fixed jaw
- Fit the cylindrical pin  $\varnothing 2$ ,
- Check the dimensions



### TASK 4:

#### Part D: Sliding plate

- Check the metal sheet for the dimension
- File the sheet metal for straightness and right angle by draw filing
- Mark the layout as per drawing and punch
- Bend the sheet metal into right angle with the help of 6mm flat by hammering
- Check for the dimension after bending
- Mark drill the  $\varnothing 4$  hole for the slot opening
- Chain drilling for the slot opening remove excess metal
- File the slot for the dimensions
- Mark drill  $\varnothing 4$ mm in the position as per drawing
- File for  $60^\circ$  angle and check with bevel protractor
- Do the radius filing and remove the burr's
- Check the raw material as per the drawing size
- Hold the rod in the three jaw chuck and true
- Turn the round for  $\varnothing 12$ mm
- Knurled the outer surface with knurling tool upto 15mm length
- Drill  $\varnothing 5$  mm and tap the drilled hole by M6 Tap
- Chamfer the side  $2 \times 45^\circ$
- Do the parting off and chamfer the other side.

### TASK 5:

#### Spanner assembly

- Check material size for all the parts
- File, mark and finish parts A & B to size
- Bend Part 'D' as per drawing
- Remove excess metal and finish to size
- File and finish square slot
- Drill and counter sink holes
- Turn, drill, tap, knurl and part off part E to size
- Step turn, cut external thread using and part off part 'C' to size
- Assemble part C & A
- Rivet and join part B and D
- Assemble all the parts together as shown in the assembly drawing.

## Dismantling and mounting of pulleys

**Objectives:** At the end of this exercise you shall be able to

- extract pulley using puller
- extract pulley using arbor press
- mount pulley on shaft.

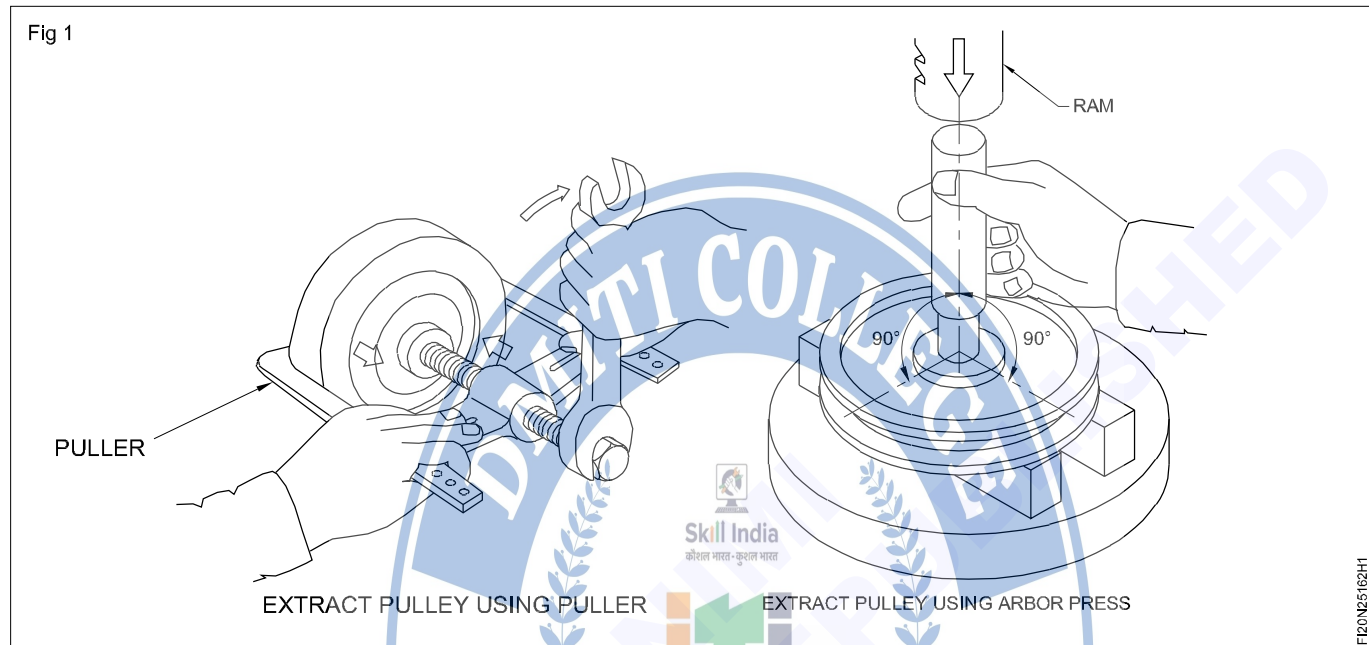

### Job sequence

#### Extract pulley from shaft

- Remove pulley using puller.
- Remove pulley using arbour press.

#### Extract pulley using puller

- Select correct size of puller, depending upon the size of the shaft and pulley.
- Clean end of the shaft using flat file, to remove any burrs or bulging on the end of the shaft.
- Place the legs of the puller diagonally opposite sides of the pulley to hold the pulley firmly . (Fig 1)

- Position the centre screw of the puller by hand screwing, so that, sufficient centre screw length is available for complete removal of the pulley from the shaft.
- Apply few drops of oil, around the shaft before removing.
- Tighten the centre screw gradually using correct size spanner and check whether the pulley is coming out freely from the shaft, if not slightly hammer on the head of the centre screw, this will cause the pulley to come out from the shaft freely.(Fig 2)

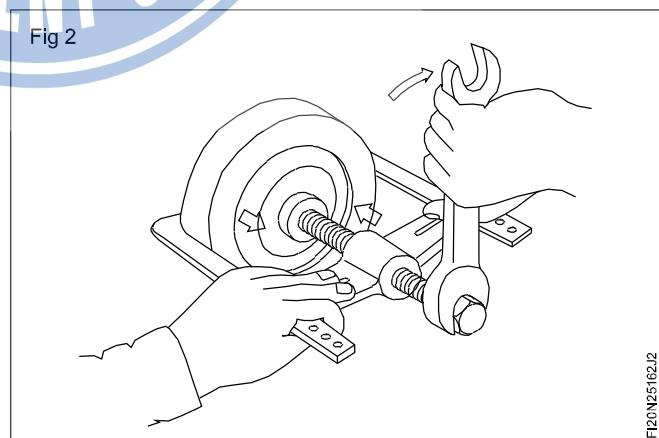
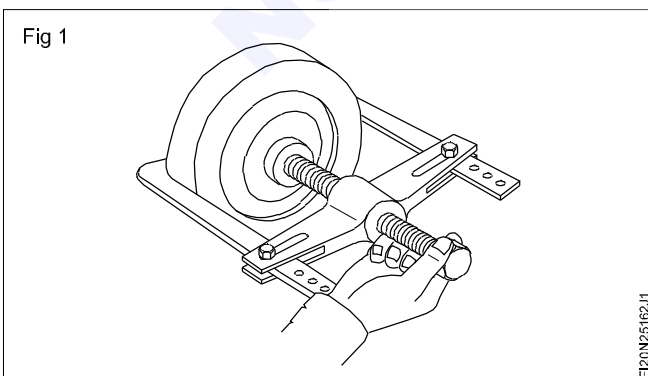

**For removing pulley from smaller shaft use Arbor press.**

**For removing pulley from longer shaft or from the shaft attached to the machine. Use proper puller.**

### Extract pulley using Arbor press

- Clean the end of the shaft with flat file to remove any burrs or bulging from the end of the shaft.
- Set the Arbor press according to the shaft it should be less than the diameter of the shaft.
- Select the mandrel according to the shaft it should be less than the diameter of the shaft.
- Select a pair of parallel blocks and position them on the bed of the press.
- Place the pulley with shaft on the parallel blocks, such that the shaft in the pulley is in line with the ram of the press. Ensure that the parallel blocks are as close as to the shaft to give maximum support.
- Apply few drops of oil around the shaft to reduce friction during removal.
- Position the mandrel on the shaft and position the ram of the press on the mandrel (Fig 3).

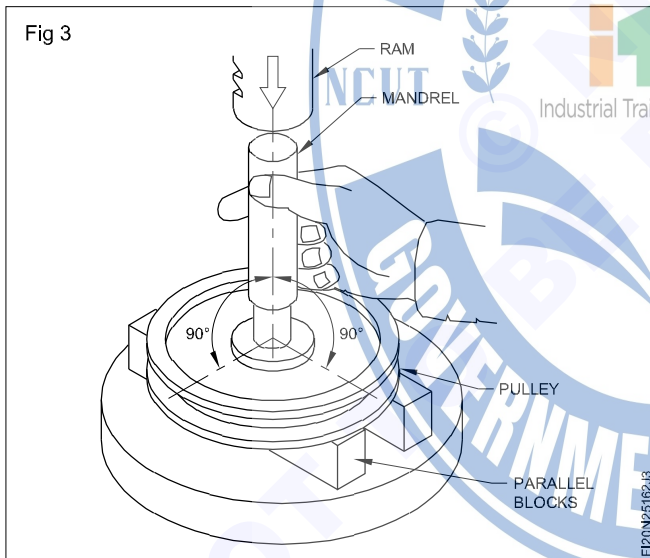

- Apply light pressure with the ram on the mandrel gradually so that the shaft is extracted out of the pulley. Apply same pressure on the ram still the shaft is completely ejected out from the pulley.
- Bring back the ram to its original position gradually and remove the mandrel.

### Assemble pulley and shaft

- Deburr the keyway in the shaft and the hub and clean the keyways.

- Check the dimensions of the shaft and the hub and the keyways.
- Check, by inserting the hub on the shaft, so that it is a tight push fit with the hands on to the shaft. Polish the shaft or scrap bore of the workpiece until this fit is obtained.
- Select a Gib head key of the correct section and length.
- Check the key for width by inserting into the keyway of the shaft, draw file the key until it is a light tap fit in the keyway. Similarly, check the key in the keyway of the hub. (Fig 4)

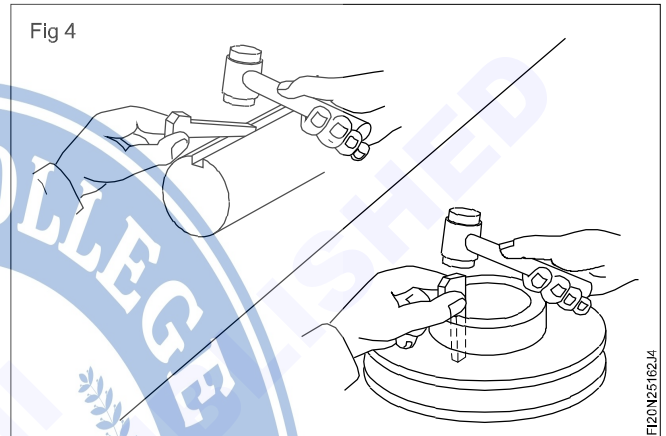

- Fit the hub on to the shaft by taping slightly with a soft hammer.
- Tap the key in to the keyway. Remove the key and check for any high spots, and file away the high spots. Repeat the above operation until the key head is approximately 15mm away from the boss of the hub. (Fig 5).
- Remove the key and check the fit on the faces.
- Fit key with a firm blow with a hammer.

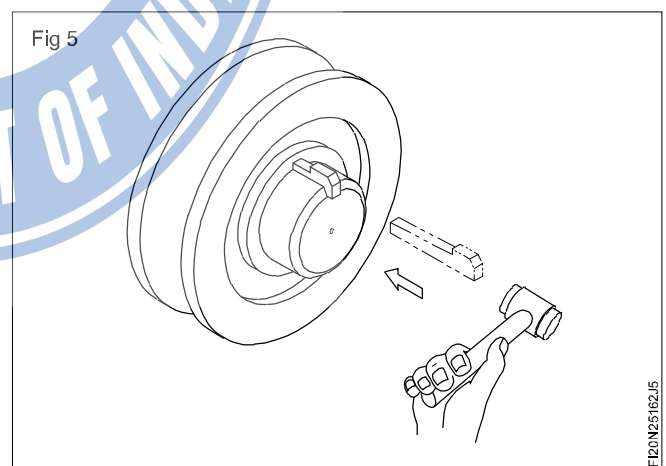

## Making and replacing damaged keys

**Objective :** At the end of this exercise you shall be able to

- assemble using feather key in hub and shaft

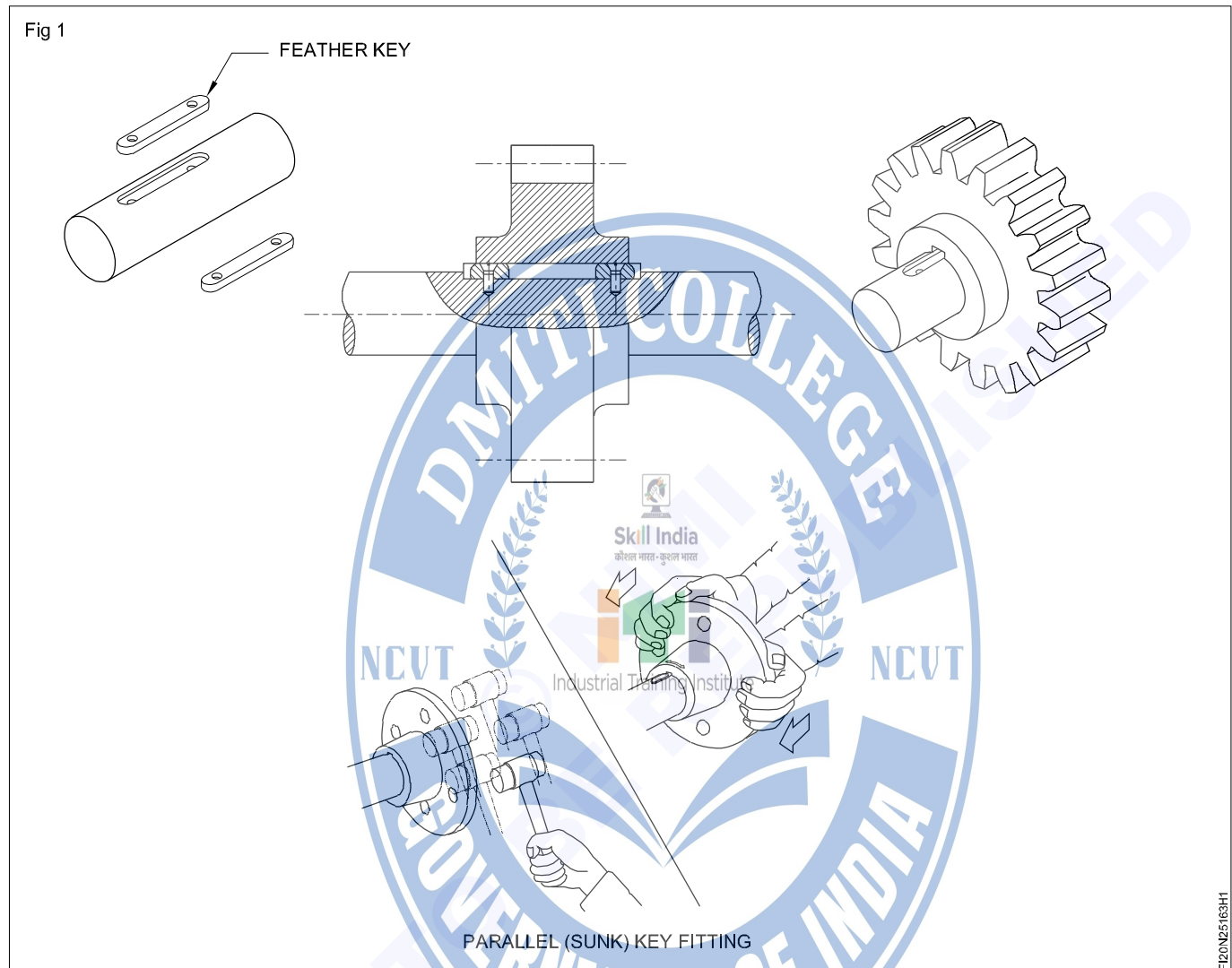

### Job sequence

- Assemble hub and shaft with parallel key.

#### Parallel key fitting

- Deburr the keyways in the shaft and the Hub, clean the keyways.
- Check the dimensions of shaft and Hub and keyways using precision instruments. (Outside dia of shaft, inside dia of hub, length, width and depth of keyway) as per the drawing (Fig 1).
- Select a length of key steel of suitable cross section depending on the size of the keyway.
- File radius at one end of the key and cut to a length plus

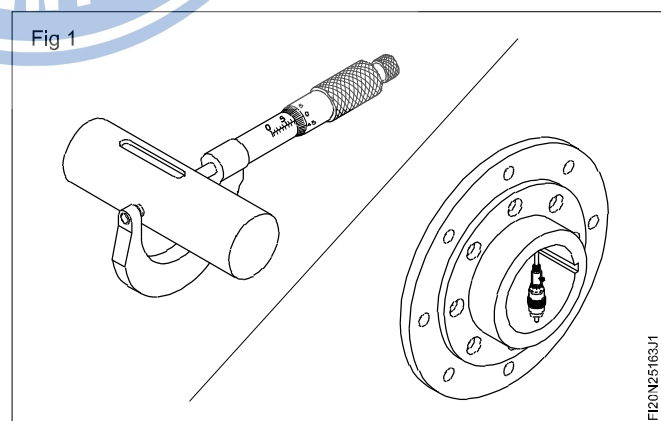

1 mm of the keyway and file other end of the key (Fig 2).

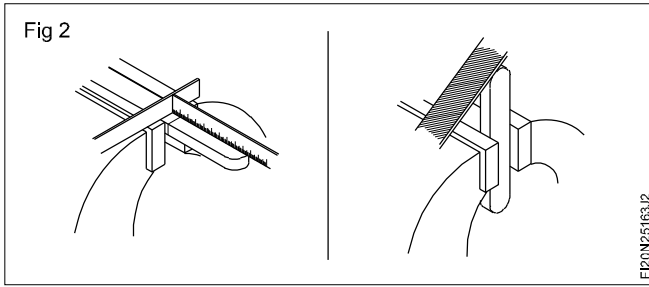

**Ensure that the key is chamfered all around in its bottom side edges.**

- Check the key width to suit the keyway in the shaft. Draw file the key, so that it is slight tap fit/light keying fit (K7-h6) with the keyway on the shaft (Fig 3).

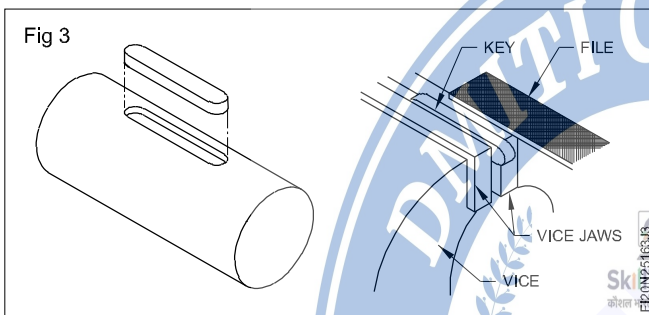

- Check the key for slight tap fit with the keyway in the Hub (Fig 4).

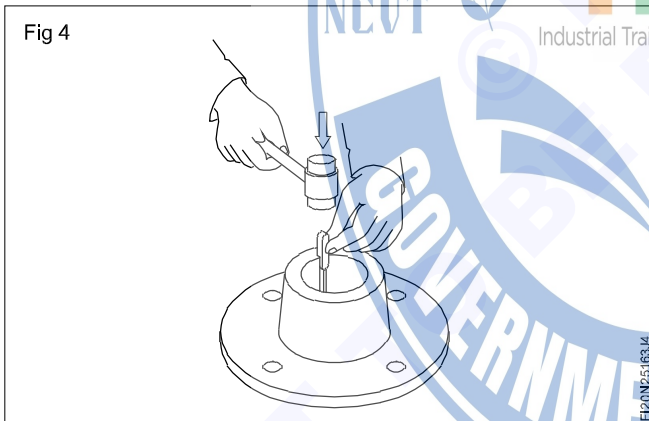

- Apply Prussian blue on all sides and bottom portion of the key so that proper bearing of key on the keyway is ascertained.
- Insert the key in the keyway of the shaft and tap with a light weight soft hammer (Fig 5).

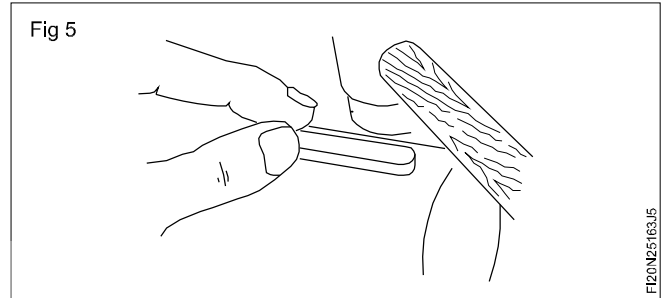

- Tap the hub on the shaft, and remove the hub from the shaft, check the key and note the high spots where the key has made contact with the keyway of the hub.
- Lightly file the high spots away, the top of the key should be approximately 0.1mm clear.
- Repeat the fitting and filing operation until the hub is fit on to the shaft to the desired position (Fig 6).

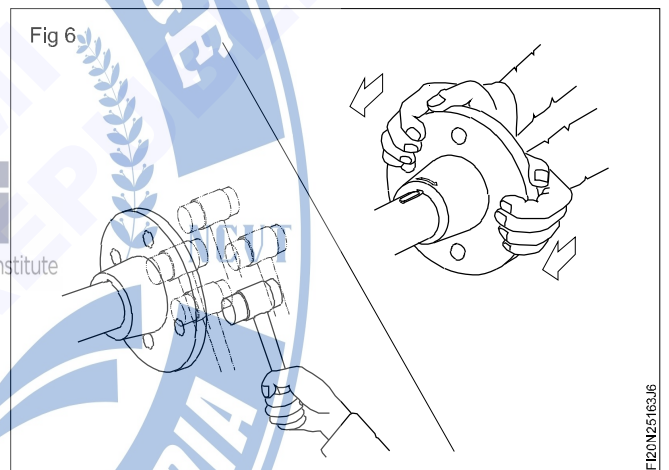

## Repairing damaged gears

**Objectives:** At the end of this exercise you shall be able to

- dismantle gear box from the machine
- check out and replace wornout or damaged parts
- assemble the gear box
- mount the gear box to the machine, check the test run.

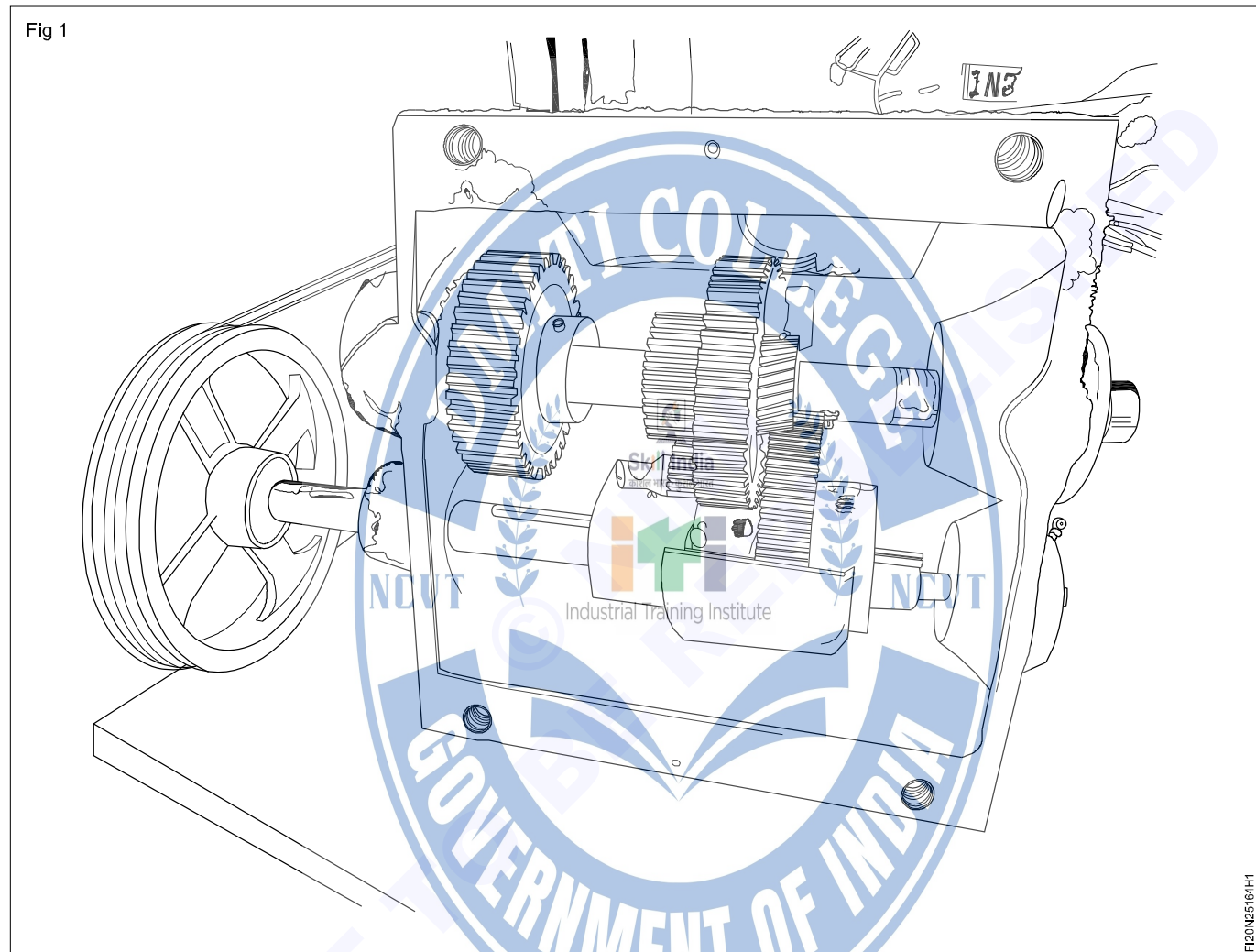

## Job sequence

### Dismantling the gear box

- Switch of the main power supply
- Inspect the shaping machine gear box.
- Dismantle the guard and belts
- Support the gear box with wooden blanks
- Unscrew the fastener's by using suitable tools (Fig 1).
- Remove the gear box and keep it on the work table
- Remove the driven pulley from the driver shaft using puller. (Fig 2)



Fig 2



F120N25164H2

- Remove the key from the drive shaft.
- Remove bearing covers and internal circlips.
- Dismantle the driver shaft by tapping the shaft using copper rod and hammer.
- Remove the bearings and sliding gear unit from the gear box by disconnecting spring loaded shifting lever.
- Remove the end nut, bearing covers, circlips and grup screws in the spacer of the driven shaft. (Fig 3)

- Remove the driven shaft by tapping the shaft using copper rod and hammer then take out the gears, spacers from the gear box.
- Thoroughly clean all the parts using kerosene and wiped out with cotton cloth. (Fig 3 & 4)

Fig 4



F120N25164H4

- Check all the part for wear and tear.
- Repair the damaged gear parts (Refer Ex No.2.5.167).
- Lubricate the parts before assemble (Fig 5)
- Assemble the gear box in reverse manner of dismantle.
- Mount the gear box with the machine.
- Check the test run with different speeds (four speed).

Fig 3

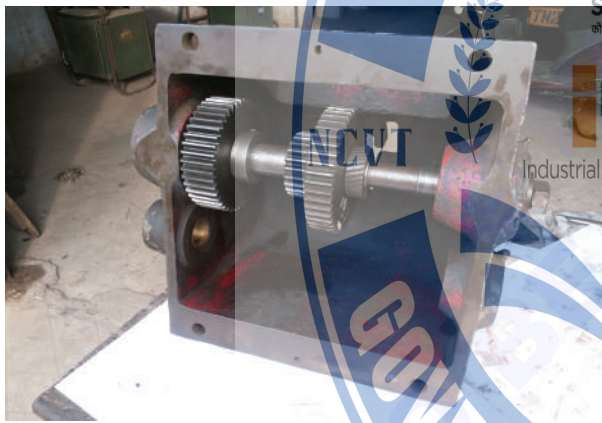

F120N25164H3

Fig 5



F120N25164H5

## Skill sequence

### Inspection of gear tooth elements

**Objectives :** This shall help you to

- check the P.C.D of a given spur gear
- check the spur gear tooth thickness
- check the teeth clearance between mating gears and backlash
- check the concentricity and wear of gears.

### Checking of the Pitch Circle Diameter (PCD) of the gear

- Select the gear to be measured and place it on the work table.

- Choose the two standard cylindrical pins or balls for measuring the gear size.
- Hold the flange micrometer, select and place cylindrical pins or balls as shown in the figure 1.

- Note down the flange micrometer reading by locking its thimble and barrel scales.
- Find out the PCD by subtracting the pin or ball diameter from the obtained micrometer reading.

**This method is only suitable for gears having even numbers of teeth.**

**Composite inspection as shown in the figure 2 is a useful shop friendly tool to determine the gear size of having any number of teeth.**

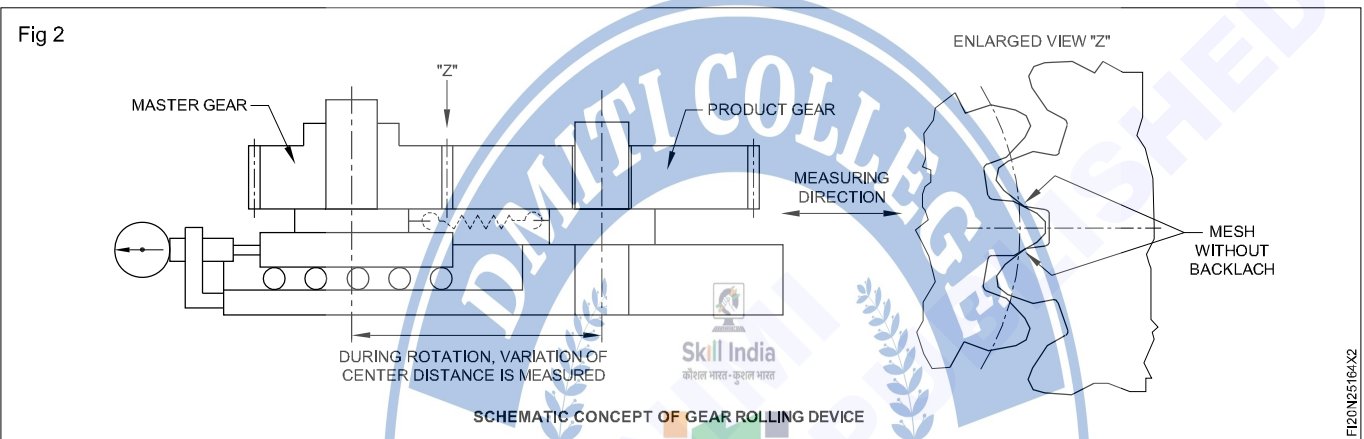
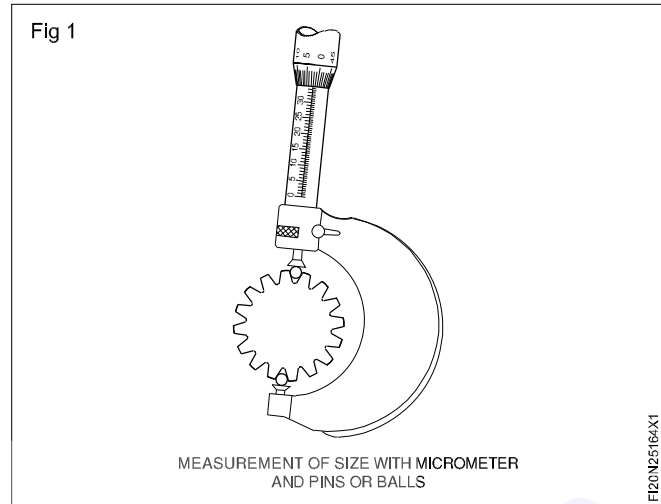

### Measuring the gear tooth thickness (Fig 3)

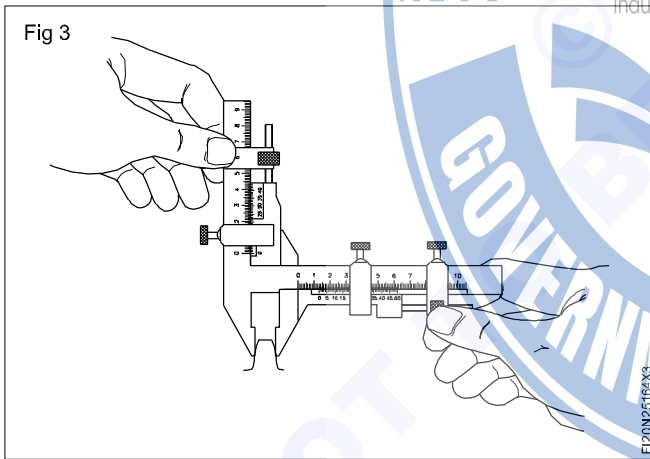

- Select the gear to be measured and hold it with a vice.
- Set the chordal addendum in vertical scale.
- Hold the gear tooth caliper properly as shown in the figure 3.
- Adjust the adjustable tongue of the gear tooth caliper to touch it with the tooth side.
- Note down the reading directly from the caliper and it will be the chordal tooth thickness.

### Checking the gear teeth clearance between mating gears and backlash (Fig 4)

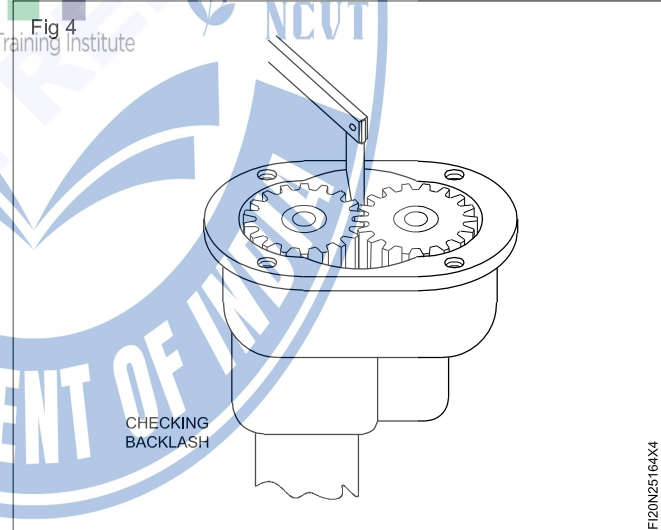

- Arrange the gears to be measured as shown in the figure.
- Hold one gear rigid and insert the feeler gauge through the gap between gear teeth of mating gears as shown.
- Note down the feeler gauge reading and it will be the backlash value.
- Compare the measured backlash value with the given table and ensure it within the permissible value (limit).

**Table 1**  
**Backlash Suggestions**

Pitch	Backlash
3P	0.013
4P	0.010
5P	0.008
6P	0.007
7P	0.006
8-9 P	0.005
10-13P	0.004
14-32P	0.003
33-64P	0.0025

- Fix the gear to be measured in a mandrel as shown in the figure.
- Select suitable ball or cylindrical pin and place it in between the gap of two teeth.
- Hold the dial indicator in such a way that it will touch the outer periphery of cylindrical pin or ball.
- Note down the dial indicator reading.
- Repeat the same procedure for all the gear teeth and simultaneously note down the dial indicator reading.
- Calculate the total runout or concentricity by subtracting maximum and minimum dial gauge reading.

**Checking the concentricity and wear of gears (Fig 5)**

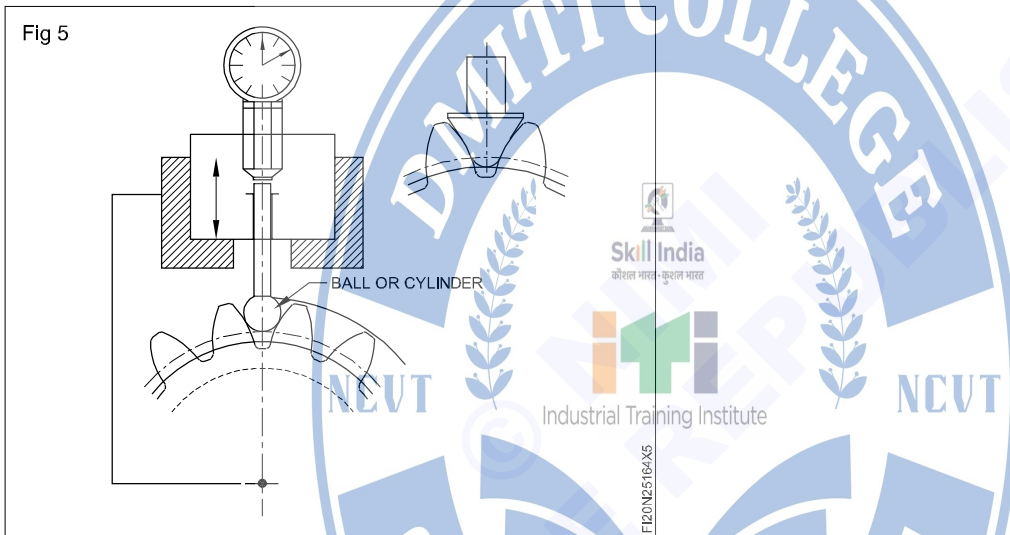

## Repair & replacement of belts and check for workability

**Objectives:** At the end of this exercise you shall be able to

- fix a belt on driver and driven pulley
- measure tension of a 'V' belt drive
- adjust belt tension with a spring balance.

### Job sequence

- Mark and cut the belt to the required length (Fig 1).

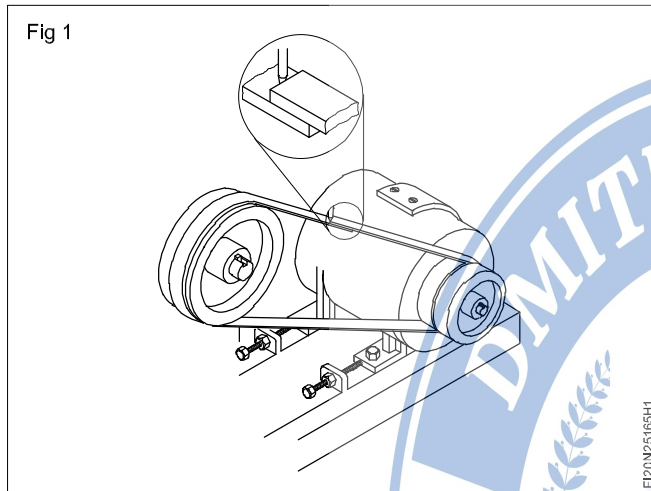

- Trim both ends of the belt square (Fig 2).

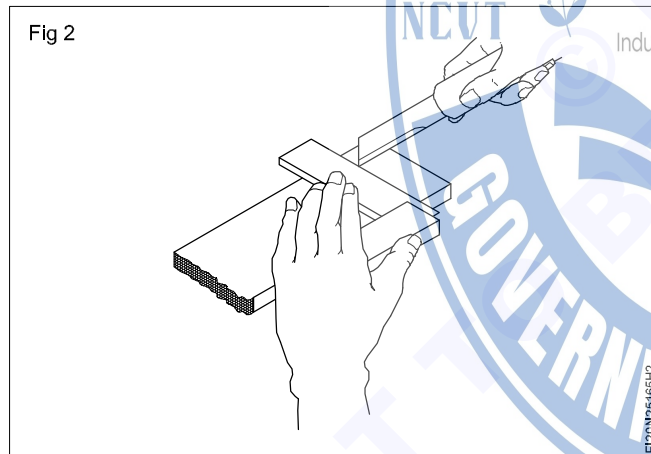

- Fit an alligator fastener centrally into the jaws of the lacing machine and fit the pin into the side of the jaws to hold the fastener in the machine (Fig 3).
- Put the belt centrally between the jaws of the machine. (Fig 4)
- Operate the machine to press the fastener into the belt until it is flush with the belt (Fig 5 & 6). Trim the edges of the fastener.
- Place the belt around the shafts beside the pulleys with the rough side against the pulleys and join both ends by the pin (Fig 7).
- Fit the belt to the small pulley end first and then run it on to the big pulley (Fig 8).

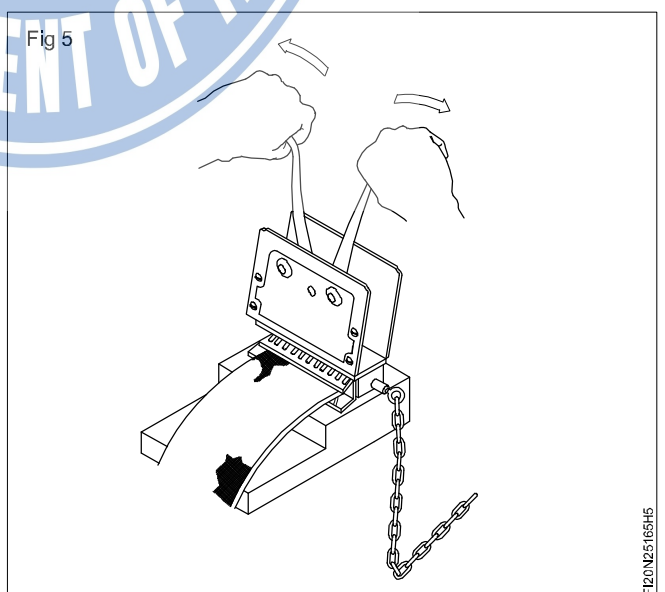
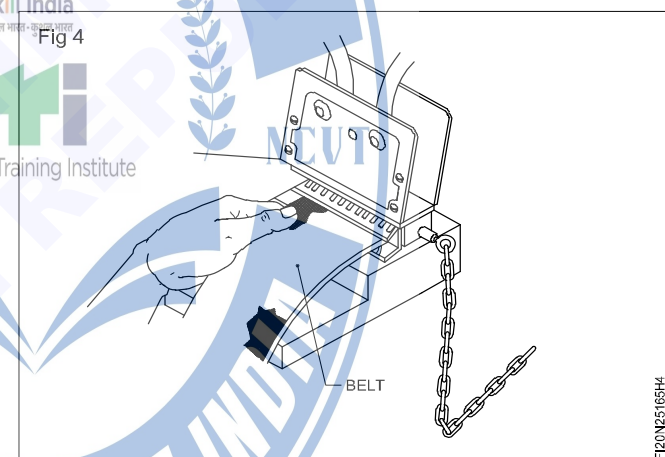
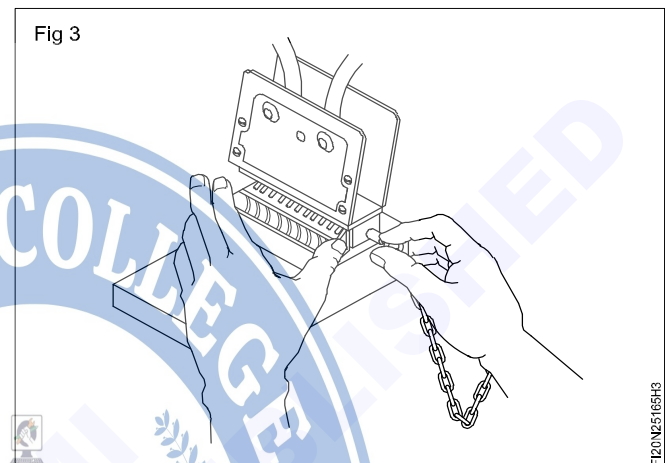

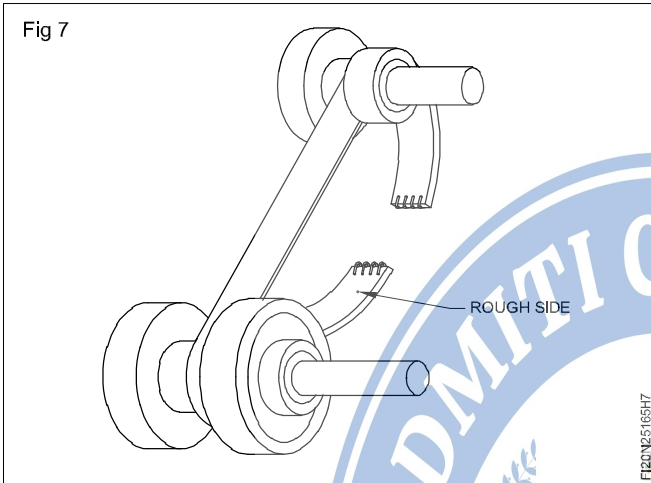
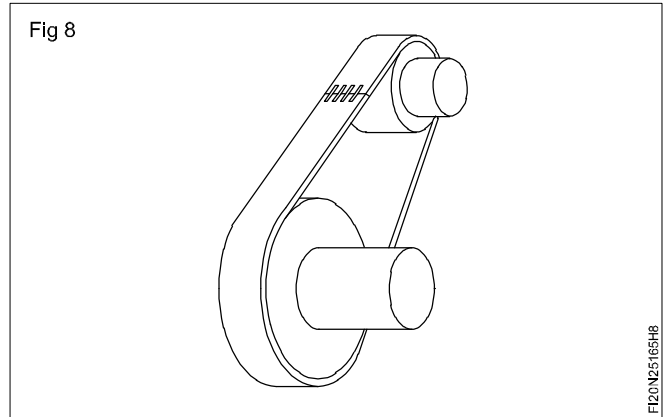
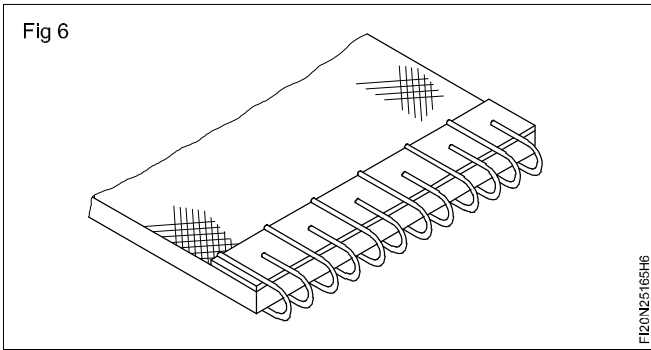

## Skill sequence

### Adjust belt tension in 'v' belt drive

**Objectives :** This shall help you to

- check belt tension using a spring balance
- adjust belt tension by tensioning bolts.

Measure the longest span length of the belt between the pulleys, using a steel tape.

Find the middle of the longest span of the belt between the pulleys.

Push this mid-point inwards, then pull it out and note the total deflection. (Fig 1)

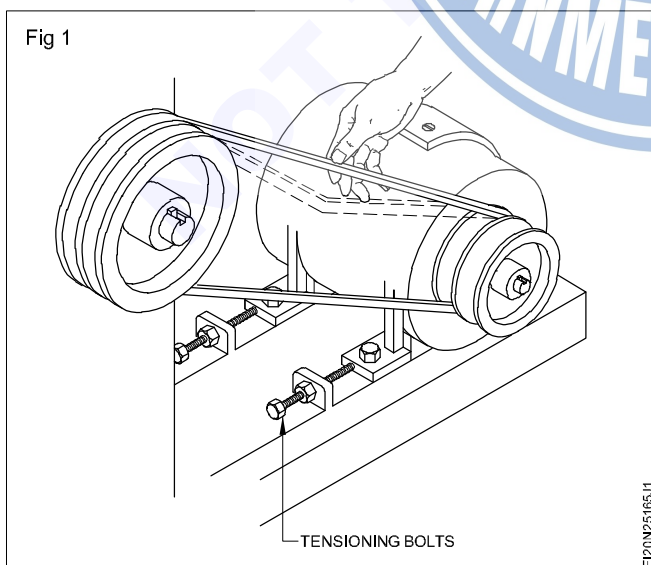

**This indicates the existing tension of the belt.**

Loosen the lock-nuts. (Fig 2)

Slacken the clamping bolts. (Fig 2)

Move the pulley with the adjusting screws to alter the tension. (Fig 2)

**The adjusting screws must be turned equally to keep the pulleys correctly aligned.**

Attach a spring balance and check the tension of the belt. (Fig 3)

Readjust the adjusting screws until the tension is correct.

Tighten the clamping bolts.

Tighten the lock-nuts.

Fig 2

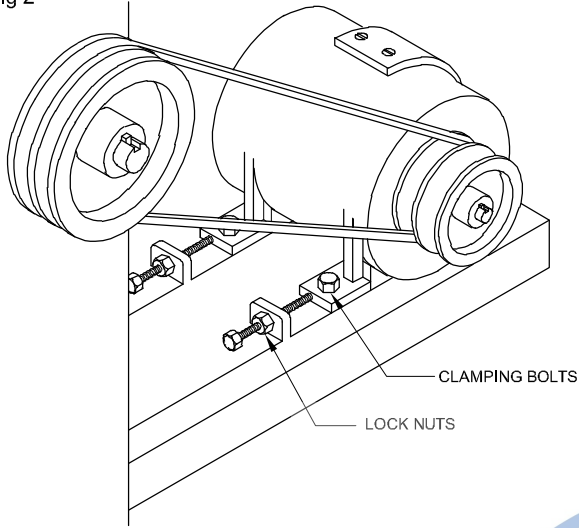

F120N25165.2

Fig 3

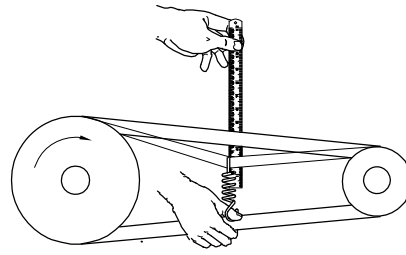

F120N25165.3





## Job sequence

### TASK 1: Angle gauge

- Check the raw material for its size
- File and finish the plate to size 60 x 20 x 3.8mm (0.4mm thick for grinding allowance)
- Mark centre lines for the 60° external Vee and relief grooves.
- Mark centres for 2 mm relief hacksawing.
- Cut off excess metal with a hacksaw from the plate, for the two 'V' grooves.
- Ensure that punch marks are visible and sufficient metal is left for finish filing
- File and finish the sides of the groove with a knife edge file
- Ensure that the width of the remaining metal on both sides of the 'V' grooves end is equal.
- Check the accuracy of the 60° angle with the template / gauge supplied.
- Repeat the steps for the 'V' groove.
- Cut off excess metal from the plate for external 'Vee' on one side.
- File and finish the side of the 'VEE' correct to the centre line.
- Cut off excess metal from the other side of 'Vee'
- File and finish the 'Vee' to the centre line
- Check the 60° angle with a vernier bevel protractor file, and finish all the edges.
- Remove burrs and check the dimensions.

### TASK 2: Template of different profiles

- Check the raw material for its size
- Remove burrs and check the raw material size.
- File the large surface with a 200mm flat second cut file (Hold the sheet on the wooden block)
- File two adjacent sides - flat and square.
- Make relief hole by drilling as per drawing.
- Mark dimensions as per drawing.
- Hacksawing and remove the excess material.
- File and finish the remaining surfaces to size and check the size.
- File and finish 60° and 45° angles and radius check with vernier bevel protractor and gauge.
- File and finish thickness to 3 mm, by fixing work on the wooden block.

**Care should be taken to maintain the correct length**

Repair of broken gear tooth by stud and repair broken gear teeth by dovetail

Objectives: At the end of this exercise you shall be able to

- repair gear tooth by stud and welding method
- repair gear tooth by dovetail method.

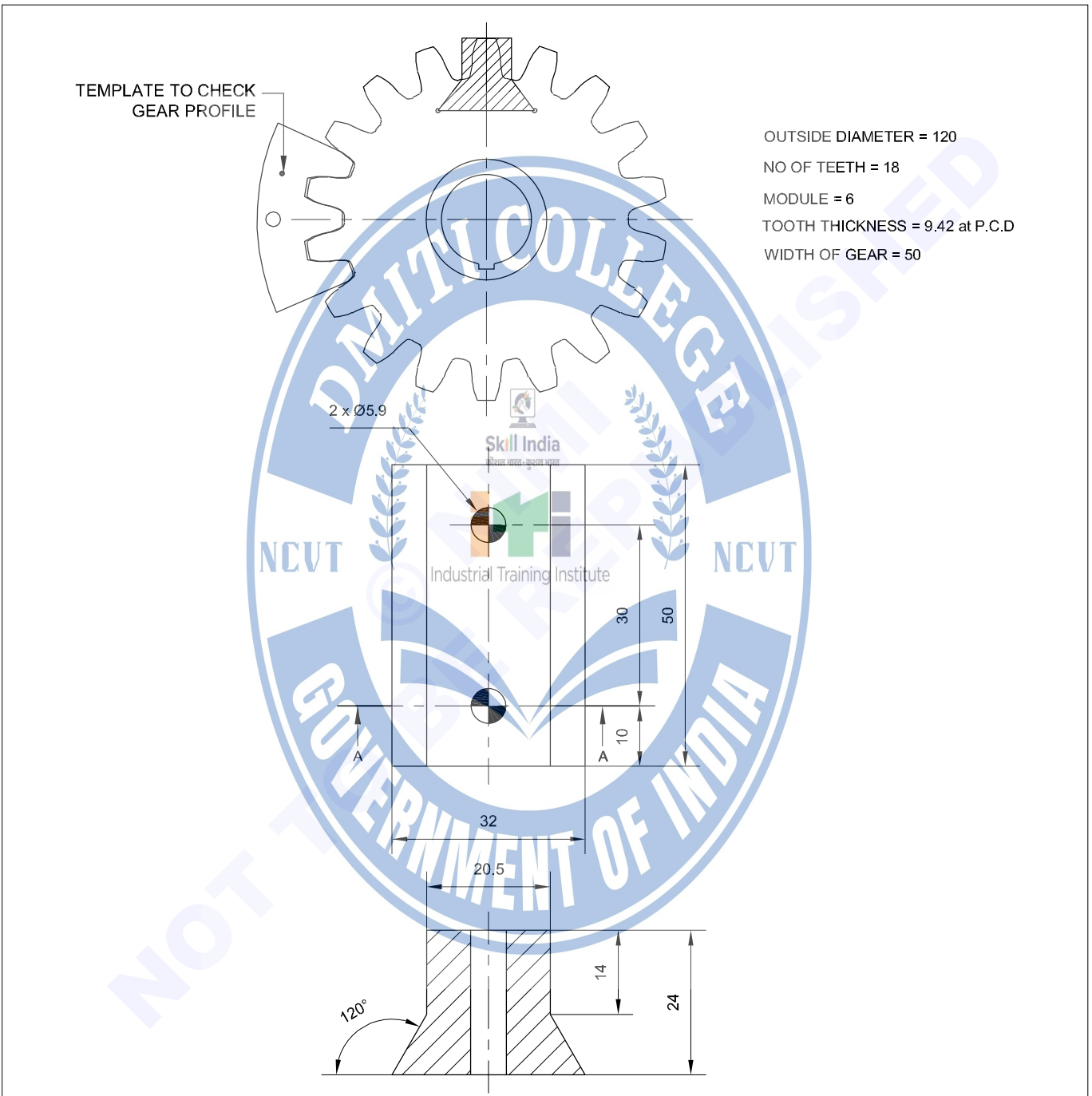

1	□36-55	-	FG 15	-	-	2.5.167
NO.OFF	STOCK SIZE	SEMI-PRODUCT	MATERIAL	PROJECT NO.	PART NO.	EX. NO.
SCALE 1:1	REPAIR OF BROKEN GEAR TOOTH BY STUD AND REPAIR BROKEN GEAR TEETH BY DOVETAIL				TOLERANCE : ±0.02 mm	TIME : 17 Hrs
					CODE NO. F120N25167E1	

## Job sequence

### TASK 1: Repair broken gear tooth (dovetail blank method)

- Support the gear against a Vee block and clamp it by parallel clamp.
- Mark the dovetail groove on the gear wheel from both sides using a vernier height gauge and vernier bevel protractor.
- Punch the marking lines (Fig 1).

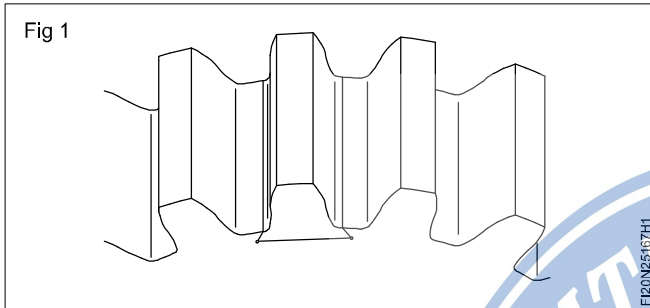

- Drill 3mm dia. relief holes one each on the corner of the dovetail.
- Remove material from the gear to shape and size of dovetail as per marking (Fig 2).

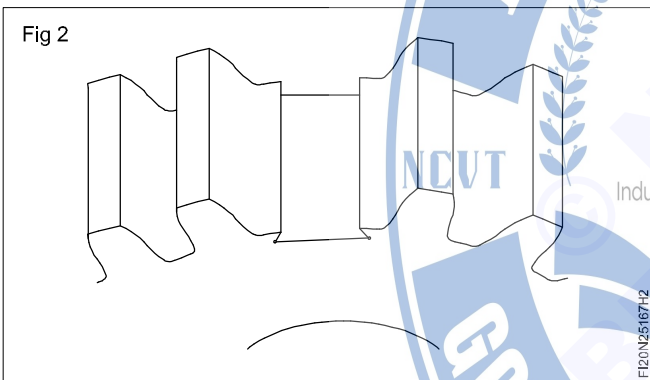

- File the blank to the profile of the gear tooth as per punch mark.
- File the dovetail portion of the blank.
- Fit the blank into the dovetail groove of the gear wheel. If necessary, file the blank till it fits in.
- Apply Prussian blue on the dovetail groove to check the high spots in the blank piece.
- Remove the high spots and make a snug fit in the dovetail groove.
- Drill 5.9mm dia. - 2 holes up to a depth of 33mm on the blank and gear wheel in assembled condition.
- Ream the holes using a hand reamer.

**Dismantle the assembly and remove the chips from the holes of the gear and the blank.**

- Assemble again and fit the dowel pins in the holes by a slight tapping.
- File the profile of the gear tooth to the correct shape.
- Use a template to check the profile.

**File the sides of the blank, flush with the gear.**

### TASK 2: Repair broken gear tooth (Welding method)

- File the broken tooth surface flat (Fig 1).

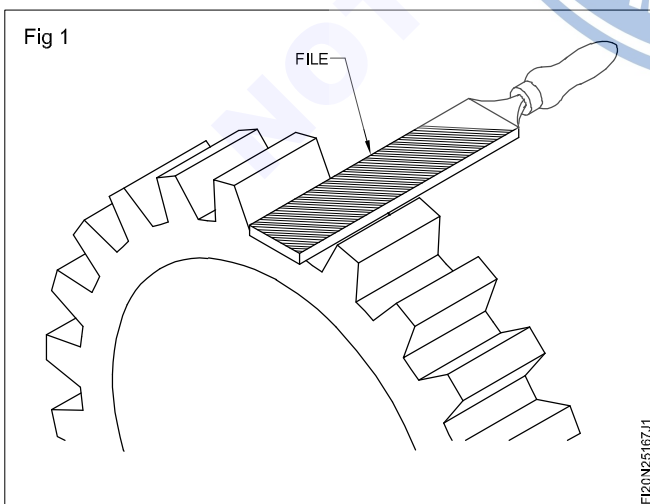

- Mark for four holes on the surface with 10mm centre distance between the holes.
- Punch the centres for drill holes (Fig 2).

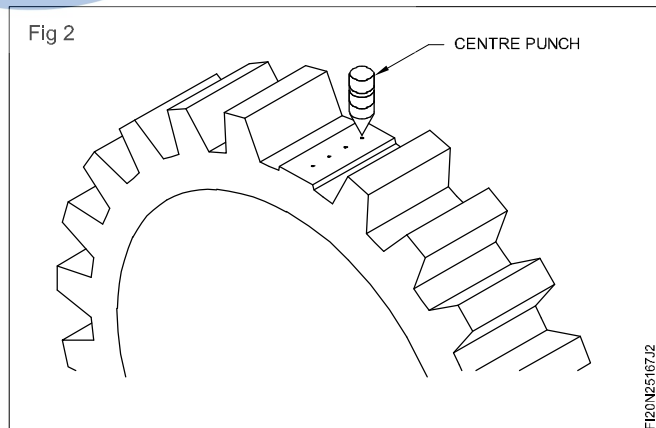

- Drill 5 mm dia. holes on the centres to a depth of 9 mm. (Fig 3).

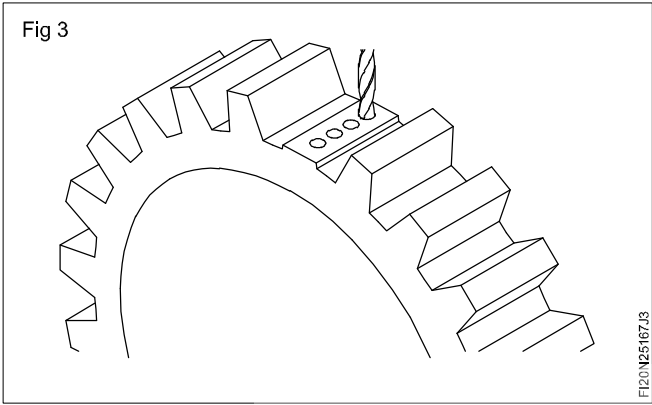

**Remove the chips from the holes.**

- Tap the holes using a M6 hand tap (Fig 4)

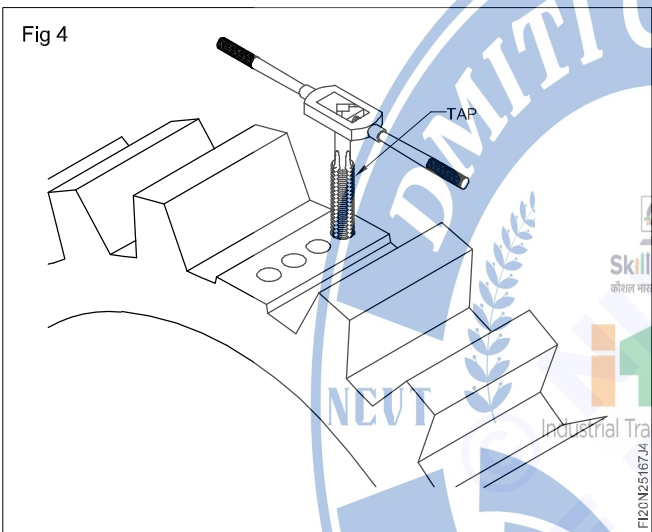

**Remove the chips and clean the tapped holes.**

- Fix up four hexagonal headed M6 bolts into the tapped holes and tighten them securely (Fig 5)

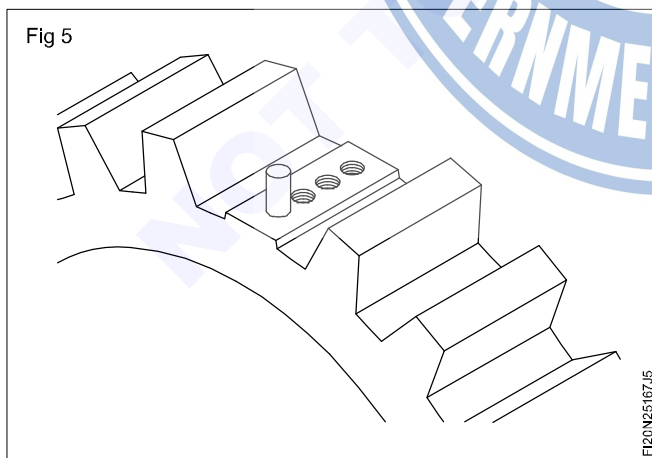

- Cut off the hexagonal head of the bolts by hacksawing.
- Build up material by welding just enough to make the tooth profile by filing (Fig 6).

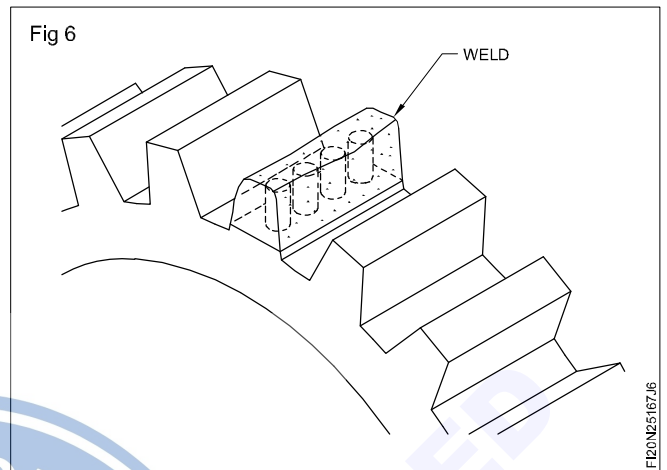

- File the built up material to tooth profile. Use a template frequently to check the profile to have correct shape and pitch (Figs 7 & 8).

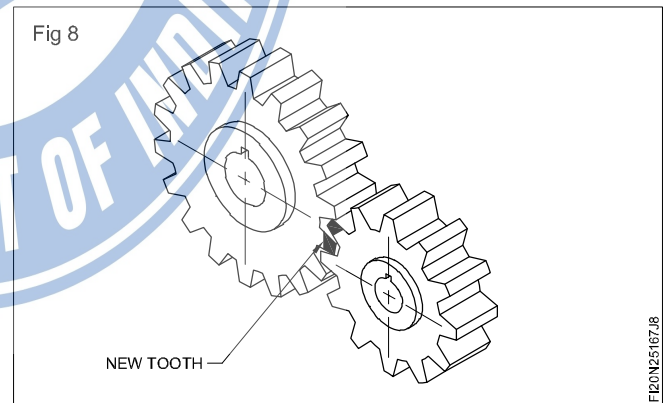
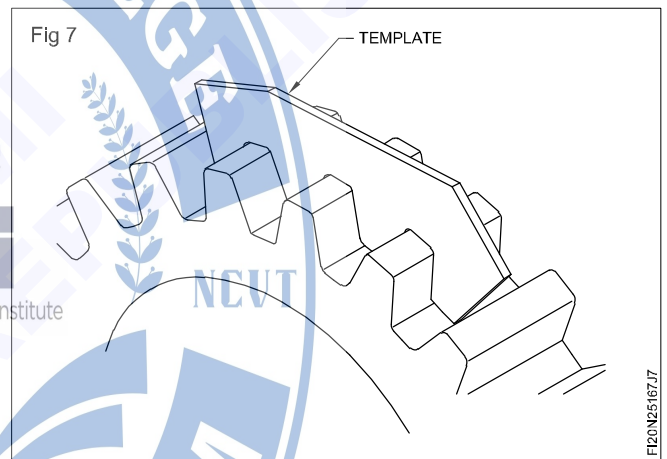

Make hexagonal slide fitting

Objectives: At the end of this exercise you shall be able to

- file and finish mating parts within  $\pm 0.02$  mm using O.S. micrometer
- file and finish mating parts having angular surfaces within  $\pm 10'$  accuracy using vernier bevel protractor.

PART - ①

60

A/F25g6

6 x Ø3 RELIEF HOLE

PART - ②

48

25H7

11.5

60

9

NOTE:

25 H7 - 25  $\begin{matrix} +0.021 \\ +0.000 \end{matrix}$

25 g6 - 25  $\begin{matrix} -0.007 \\ -0.020 \end{matrix}$

A/F - ACROSS FLATS (OPOSITE SIDE OF THE HEX BOLT)

1	65 ISF 10 - 52	-	Fe310	-	2	2.5.168
1	HEX A/F 27 - 63	-	Fe310	-	1	
NO.OFF	STOCK SIZE	SEMI-PRODUCT	MATERIAL	PROJECT NO.	PART NO.	EX. NO.
SCALE 1:1	<b>MAKE HEXAGONAL SLIDE FITTING</b>				TOLERANCE $\pm 0.02$ mm	TIME : 16 Hrs
					CODE NO. F120N25168E1	

## Job sequence

### Task 1 :

- File the surface and two adjacent edges at right angle to each other.
- Check the squareness.
- Refer the job drawing and do the marking as per the dimensions given (Fig 1).

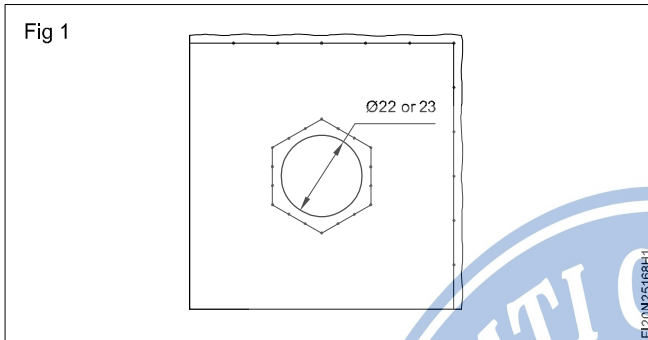

- File the excess material and maintain the dimension 60 x 48 mm with vernier caliper.
- Check the squareness with square head.

- To make the hexagonal cut out, drill a 22 or 23mm dia. drill hole in the centre. File the hexagonal shape with a square file or triangular file (Fig 2).
- At this stage make 6 relief hole in the corners by  $\varnothing 3$  mm drill.
- Finish the hexagonal shape and check the angle by the help of protractor head. ( $120^\circ$ )

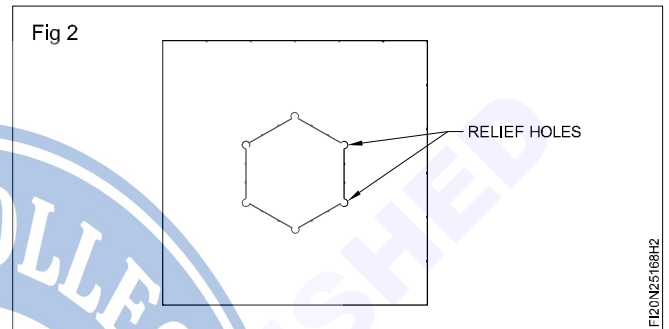

### Task 2 :

- Check the dimension in side and parallelism of faces with a vernier caliper.
- File the end of the given rod at right angle to the axis.
- Mark the hexagon as per the dimensions given in the drawing (Fig 3).

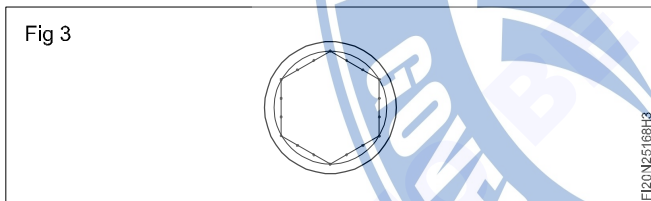

- File one side up to the marked line. Check the parallelism through out the length.
- File the adjacent side and check the angle ( $120^\circ$ ) by protractor head.

- File and finish the other sides also (Fig 4).

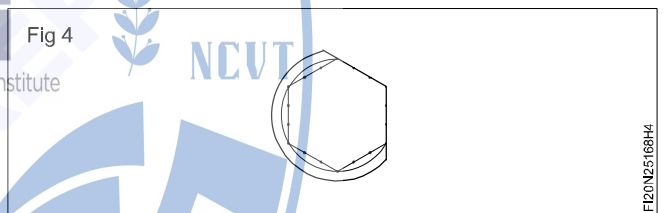

- Finally check the flat dimension and other sizes and assemble in the hexagonal slot.
- Place the female part on a wooden block. File and finish both surfaces with a smooth file and maintain the thickness.
- Remove the burrs from the edges.
- Check for Hexagon slide fitting.

**Prepare different types of documentation as per industrial need by different methods of recording information**

**Objectives:** At the end of this exercise you shall be able to

- prepare and fill up batch processing record in format
- prepare and fill up bill of materials (BOM)
- prepare and fill up production cycle time in format
- prepare and fill up daily production report in format
- prepare and fill up manufacturing stage inspection report format.

**TASK 1: Documentation 1**

**Note:**

- Instructor/ Training Officer should arrange for a industrial Visit near by your institute, collect inputs and fill up format as required.
- Trainees will be guided by the concerned instructor/ Training Officer.
- Collect necessary information forms and instruct the trainees to reproduce the format and guide them to fill it up.

**Job sequence**

- Study the different types of documentation provided in (format).  Prepare the required format with the knowledge gained during the industrial visit.
- Visit to the industry and collect the input / information from industry and fill it up in all the format.  Record relevant information in the format.
- Get it check by your Instructor / Training Officer.

**BATCH PROCESSING RECORD - FORMAT - 1**

Batch Processing Record		
Description of job	Batch no. :	
Part no. :	Batch quantity :	
Name of part :	Batch record no. :	
	Purchase order no. :	
Description of process :		
Manufacturing Organisation :		
Period of manufacture (Year - Qtr):	Start date of manufacture:	End date of manufacture:
Number of pages according to batch:	Inserted pages:	Manufacturing facilities:
Total number of pages		
1. Operator / Technician	Date	Name and signature
2. Production in-charge:	Date	Name and signature
3. Section manager	Date	Name and signature
4. Plant in-charge:	Date	Name and signature
5. Production in-charge:	Date	Name and signature
Remarks (if any)		



DAILY PRODUCTION REPORT - FORMAT - 4

Date:		Daily Production Report										Organisation Name:	
		Department:		Section:									
Process - I		Process-II		Process-III		Process-IV		Quality Control		Packing			
Planned	Completed	Planned	Completed	Planned	Completed	Planned	Completed	Planned	Completed	Planned	Completed		
Job Order No.													
Quantity													
Material & Size													
Job Order No.													
Quantity													
Material & Size													
Job Order No.													
Quantity													
Material & Size													
Job Order No.													
Quantity													
Material & Size													

Signature of section Incharge

**MANUFACTURING STAGE INSPECTION REPORT - FORMAT-5**

Organisation Name:										Status: From Date ...../...../..... To Date ...../...../.....			
Department / Section:										Inspection Record No. & Date		Inspection/ Test conducted by	
Date	Product ID/ Code	Customer	P.O. No. & Date	Job Order No.	J.O. Date	Process	Qty	Accepted	Rejected				

## TASK 2: Documentations - 2

**Objectives :** At the end of this exercise you shall be able to

- prepare and fill job card in format
- prepare and fill work activity log in format
- prepare and fill batch production record
- prepare and fill estimation sheet in format
- prepare and fill maintenance log in format
- prepare and fill the history sheet of machinery and equipment in format
- prepare and fill maintenance record in format.

**Note:**

- Instructor / Training Officer should arrange for a industrial visit near by your institute, collect inputs and fill up in format as required.
- Trainees will be guided by the concerned instructor/ Training Officer.
- Collect necessary information forms and instruct the trainees to reproduce the forms and guide them to fill it up.

### Job sequence

- Study the different types of documentation provided in (format).
- Visit to the industry and collect the input/ information from industry and fill it up in all the format.
- Prepare the required format with the knowledge gained during the industrial visit.
- Record relevant information in the format.
- Get it checked by your instructor/ Training Officer.

Skill India  
कौशल भारत - कुशल भारत  
**JOB CARD - FORMAT-1**

<b>Job Card</b>		Doc No.					
		Rev No.					
		Date					
Order Starting Date							
Customer							
Work Order No.							
Details							
S.No.	Date	Production Line Description	Time (Minutes)			Location Time	Remarks
			Start Time	End Time	Total Time		

**WORK ACTIVITY LOG - FORMAT-2**

<b>Organisation Name:</b>			
<b>Department:</b>			
<b>Section:</b>			
<b>Employee Name:</b>			
<b>Supervisor Name:</b>			
<b>Date:</b>			
<b>Start / Stop</b>	<b>Operations performed</b>	<b>Equipment / Machinery/ Instruments used</b>	<b>Remarks</b>
8.00 to 9.00 a.m.			
9.00 to 10.00 a.m.			
10.00 to 11.00 a.m.			
11.00 to 12.00 noon			
12.00 to 1.00 p.m.			
1.00 to 2.00 p.m.		 <b>Skill India</b> कौशल भारत - कुशल भारत	
2.00 to 3.00 p.m.			
3.00 to 4.00 p.m.			

**BATCH PRODUCTION RECORD - FORMAT-3**

<u>Batch Production Record in accordance with batch processing record</u>			
Manufacturing Organisation Name: _____			
Description of job: _____			
Name of part: _____			
Batch No.: _____			
The following deviations have appeared (continued)			
<b>No. process step</b>	<b>Name of processing step</b>	<b>Documented page no.</b>	<b>Short description of deviation</b>
1	<u>Raw material preparation:</u> Operation 1: _____ Operation 2: _____ Operation 3: _____		1. _____ 2. _____ 3. _____ 4. _____
2	<u>Sizing of material:</u> Operation 1: _____ Operation 2: _____		1. _____ 2. _____ 3. _____

**ESTIMATION SHEET - FORMAT-4**

Part Name: _____		Part No.: _____		Part Drawing	
Assembly: _____		Material: _____			
Assembly No.: _____		Stock size: _____			
Operation No.	Operation description	Machine	Estimated time	Rate / piece per hr.	Tools

Prepared by: \_\_\_\_\_

Date: \_\_\_\_\_

Approved by: \_\_\_\_\_

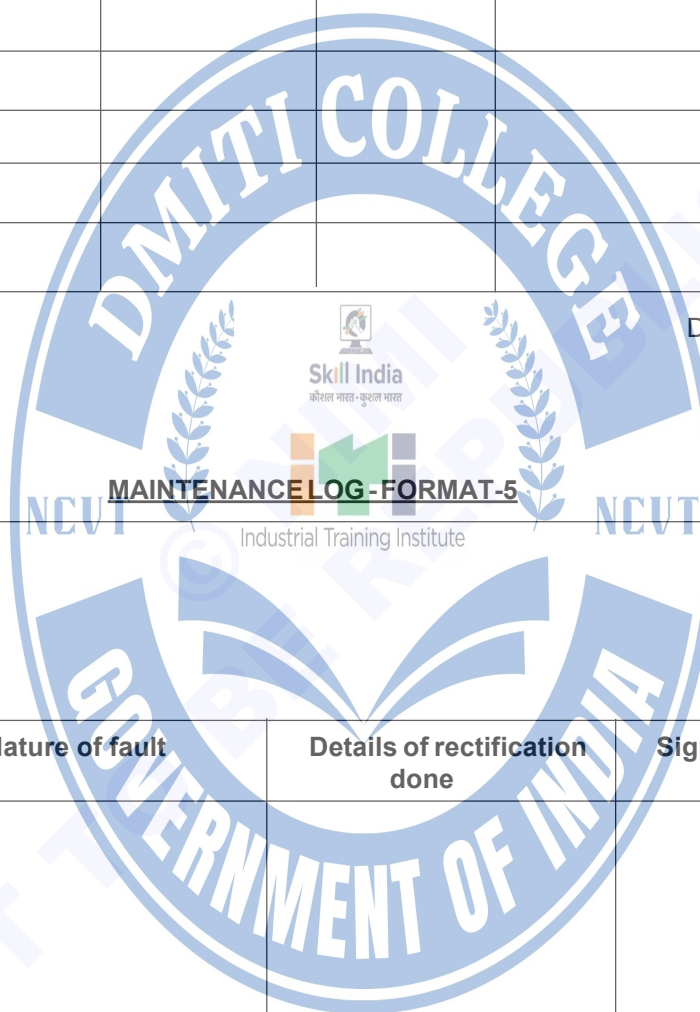

Organisation Name :				
Department :				
Section :				
Name of the machine :				
S. No.	Date	Nature of fault	Details of rectification done	Signature of in-charge

**MACHINERY AND EQUIPMENT RECORD - FORMAT-6**

Organisation Name :			
Department :			
Section :			
<b>History sheet of machinery &amp; Equipment</b>			
Description of equipment			
Manufacturer's address			
Supplier's address			
Order No. and date			
Date on which received			
Date on which installed and placed			
Date of commissioning			
Size:	Length x Width x Height	 <b>Skill India</b> कौशल भारत - कुशल भारत	
Weight		 <b>ITI</b> Industrial Training Institute	
Cost		 	
Motor particulars	Watts/H.P./	r.p.m:	Phase:      Volts:
Bearings/ spares/ record			
Belt specification			
Lubrication details			
Major repairs and overhauls carried out with dates			

**PREVENTIVE MAINTENANCE RECORD - FORMAT-7**

Organisation Name :			
Department :			
Section :			
Name of the Machine :		Location of the machine :	
Machine Number :			
Model No. & Make :			
<b>Check list for machine inspection</b>			
<b>Inspect the following items and tick in the appropriate column and list the remedial measures for the defective items.</b>			
Items to be checked	Good working/satisfactory	Defective	Remedial measures
Level of the machine			
Belt/chain and its tension			
Bearing condition (Look, feel, listen noise)			
Driving clutch and brake			
Exposed gears			
Working in all the speeds			
Working in all feeds			
Lubrication and its system			
Coolant and its system			
Carriage & its travel			
Cross-slide & its movement			
Compound slide & its travel			
Tailstock's parallel movement			
Electrical controls			
Safety guards			
Inspected by			
Signature			
Name:			
Date:			
			Signature of in-charge

Geometrical shaped fittings

Objectives: At the end of this exercise you shall be able to

- mark and file spline on the shaft
- mark and file internal spline in the hub
- file and assemble hub and spline shaft.

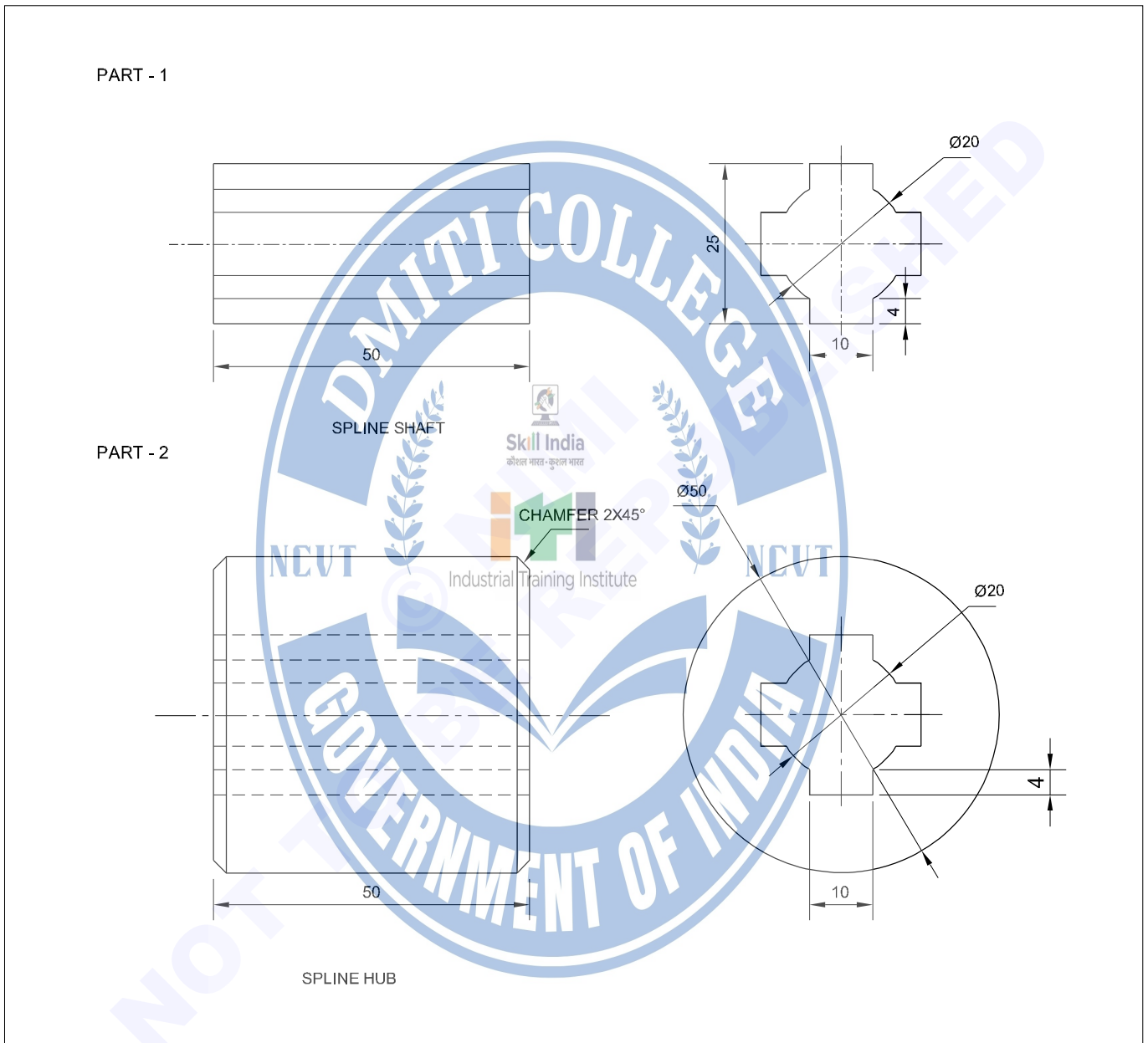

1	Ø50-55		Fe 310	-	2	2.5.170
1	Ø28-55		Fe 310	-	1	
NO.OFF	STOCK SIZE	SEMI-PRODUCT	MATERIAL	PROJECT NO.	PART NO.	EX. NO.
SCALE 1:1					TOLERANCE:±0.02 mm	
<p style="text-align: center;"><b>GEOMETRICAL SHAPED FITTINGS</b></p>					TIME : 15 Hrs	
					CODE NO. FI20N25170E1	

## Job sequence

- Check the raw material size using steel rule.
- File raw metal to over all size part 1  $\varnothing 28 - 50\text{mm}$  and part - 2  $\varnothing 50 - 50\text{mm}$ .
- Apply marking media on part 1 and part 2.
- Mark off spline key ways on part 1 and 2 by keeping on 'V' blocks using vernier height gauge and try square as per job drawing.
- Punch witness mark on part 1 and part 2.

### Part 1

- Cut and remove the excess metal in Part 1 by Hacksawing and chipping and file to size and shape using flat file, safe edge file, square file and half round file bastard, second cut and smooth grade of files.
- Check the spline shaft size using vernier caliper.

### Part 2

- Hold the part 2 in drilling machine table.
- Fix centre drill in drilling machine spindle.
- Drill centre drill, to locate centre of the round rod.
- Remove centre drill and fix  $\varnothing 6\text{mm}$  drill in drilling machine spindle and drill pilot of the hole.

- Similarly, enlarge the pilot hole using different diameter drill and finally drill  $\varnothing 20\text{mm}$  and enlarge the hole.
- Hold the job in benchvice and file key way slot size 10mm width X 4mm depth using square file bastard, second cut and smooth grade of file.
- Similarly, file other three keyways slot to the size as per job drawing.
- Check the key way slots sizes using vernier caliper.
- Finish file on part 1 and 2 and assemble as shown in job drawing and slide it (Fig 1).

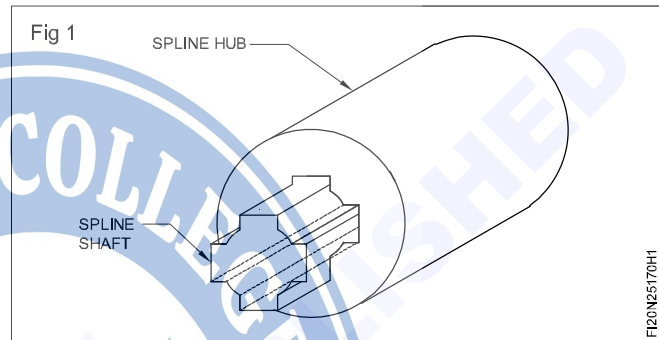

Apply thin coat of oil and preserve it for evaluation.

## Skill sequence

### Marking of a job with vernier height gauge

**Objective :** This shall help you to

- mark concentric and eccentric centre lines of a job by using a vernier height gauge.

**The height gauge marking is more accurate than the scribing block marking.**

**The marking surface must be free from sharp edges and unevenness.**

Clamp the finish turned rod in the 'V' block with the help of the clamps.

Apply marking media on both faces of the job.

Set the scriber point on the top edge of the job (Fig 1).

Move the height gauge scriber over the round surface to get a feel that the scriber bottom face is contacting the work periphery (Fig 1).

Lock the slides and note down the reading of the scales.

Subtract half the diameter from the reading and set the height gauge for that reading. (Fig 2)

Scribe a horizontal line on both faces. (Fig 2)

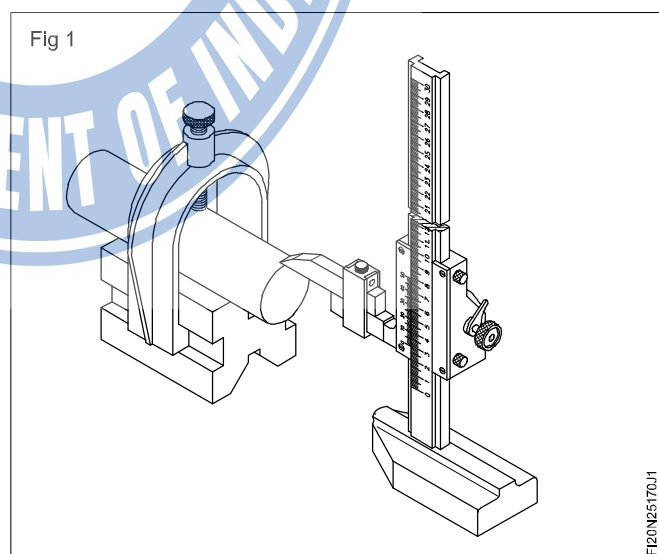

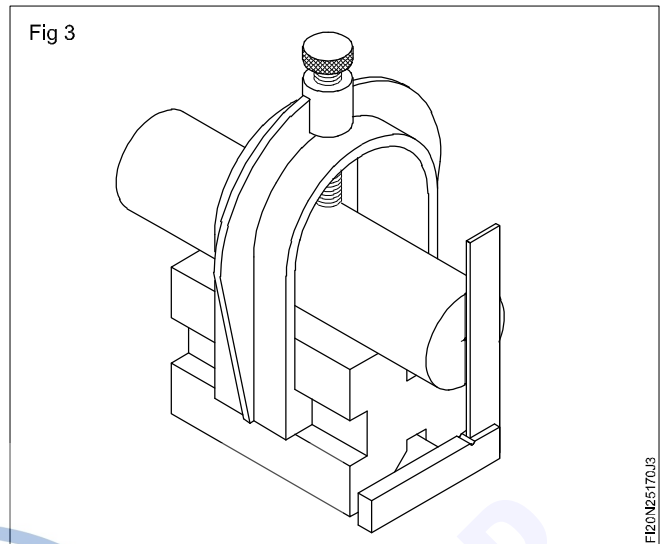
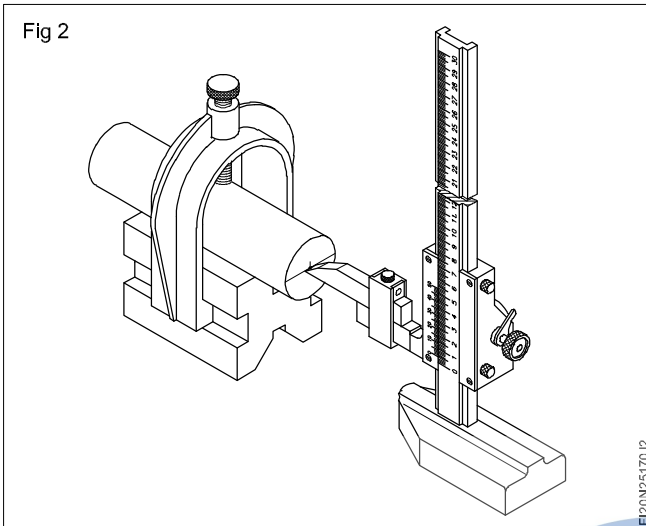

Release the workpiece from the clamp and rotate the workpiece through  $90^\circ$ . Set the line at  $90^\circ$  with the help of a try-square. (Fig 3)

Clamp the workpiece to the 'V' block.

Scribe horizontal lines on both faces with the same reading which is set for centre position. (Fig 4)

Add eccentricity amount to the above reading and reset the height gauge for the new reading. (Fig 4)

Scribe horizontal lines on both faces. (Fig 4)

Release the workpiece from the 'V' block.

Punch mark on both sides both concentric and eccentric centre points.

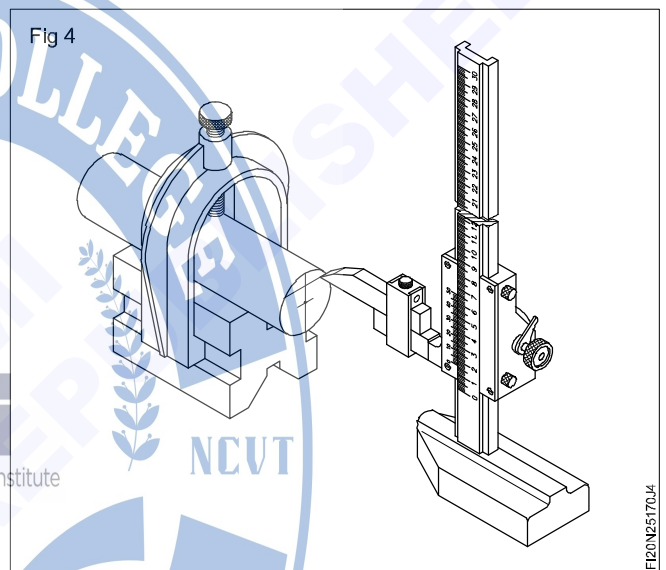

## Checking parallelism using dial test indicator

**Objective :** This shall help you to

- check parallelism of faces using a dial test indicator.

### Checking Parallelism

For checking parallelism and flatness of surfaces, dial test indicators are mostly used.

#### Procedure

Assemble the dial test indicator on the stand.

Ensure that the surface plate and the dial test indicator stand base are cleaned.

Remove burrs from work surface, and clean.

**Use fine cotton cloth for cleaning.**

Check the free movement of the plunger. (Fig 1)

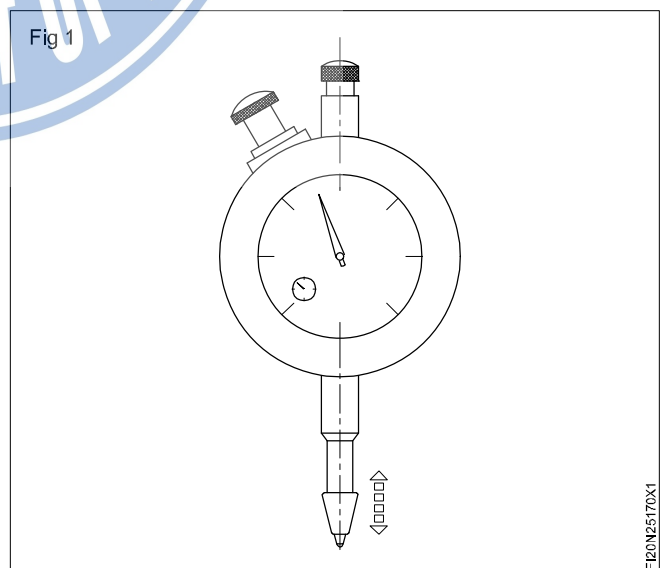

Place the workpiece below the dial test indicator and set the plunger.

A half-turn pressure of the pointer will be adequate. The plunger should be perpendicular to the work surface. (Fig 2)

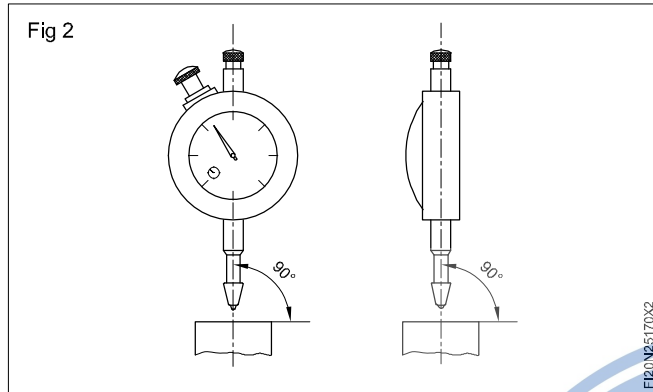

Unlock the bezel clamp. Set the reading to zero.

Slide the workpiece on the surface plate below the dial test indicator. (Fig 3)

Note the reading.

Repeat the same step at three places longitudinally and transversely.

Note the reading and determine the differences. (Fig 4)

**Precaution**  
**Do not apply oil on the plunger of the dial test indicator.**  
**Avoid sudden jerks to the plunger.**

