

AC/DC drives

Objectives: At the end of this lesson you shall be able to

- state the classification types and working of AC & DC drives
- state the applications of AC & DC drives
- describe the block diagram, parts of DC drive and advantages and disadvantages of DC drives.

Electrical drives

An electric drive can be defined as an electromechanical device for converting electrical energy into mechanical energy to feed motion to different machines and mechanisms for various kinds of process control. (Fig 1)

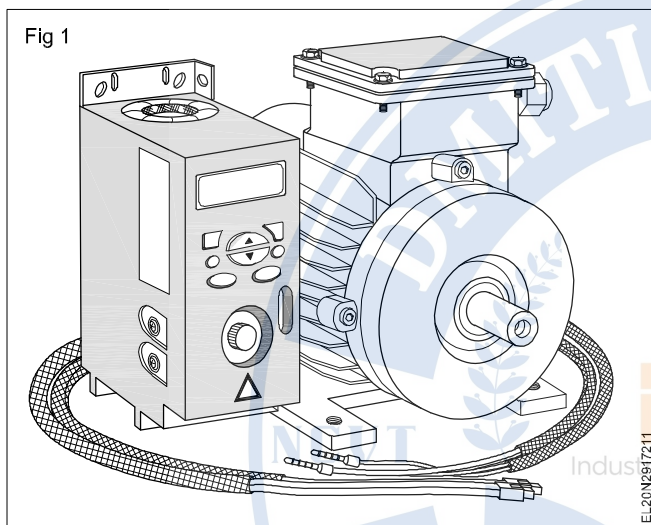

Motion control is required in large number of industrial and domestic applications like transportation, systems, rolling mills, paper machines, textile mills, machine tools, fans, pumps, robots, washing machines etc.

Systems employed for motion control are called Drives, and may employ any of prime movers such as diesel or petrol engines, gas or steam turbines, steam engines, hydraulic motors and electric motors; Supplying mechanical energy for motion control Drives employing electric motors are known as Electrical drives. The block diagram of an electric drive is shown in Fig 2.

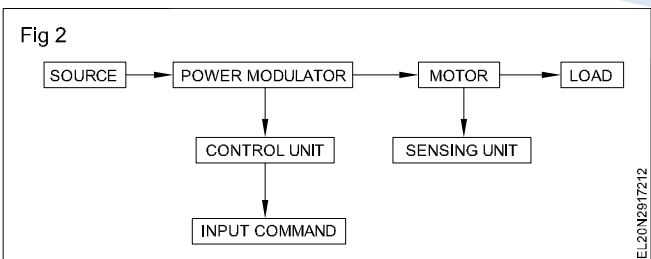

Types of electric drives

- i According to mode of operation
 - Continuous duty drives
 - Short time duty drives

- Intermittent duty drives
- ii According to means of control
 - Manual
 - Semi automatic
 - Automatic
- iii According to number of machines
 - Individual drive
 - Group drive
 - Multi - motor drive
- iv According to dynamics and transients
 - Uncontrolled transient period
 - Controlled transient period
- v According to methods of speed control
 - Reversible and non - reversible uncontrolled constant speed
 - Variable position control
 - Reversible and non - reversible smooth speed control

Advantage of electrical drives

- 1 They have flexible control characteristics.
- 2 Drives can be provided with automatic fault detection systems. Programmable logic controller (PLC) and computers can be employed to automatically control the drive operation in a desired sequence.
- 3 They are available in wide range of torque, speed and power.
- 4 They are suitable to almost any operating conditions such as explosive and radioactive environments.
- 5 It can operate in all the four quadrants of speed - torque plane.
- 6 They can be started instantly and can immediately be fully loaded.
- 7 Control gear requirement for speed control, starting and braking is usually simple and easy to operate.

The requirement of refuel is not necessary.

Choice (or) selection of electrical drives: Choice of an electric drive depends on the important factors are.

- 1 Steady state operating conditions requirements. Nature of speed torque characteristics, speed regulation, speed range, efficiency, duty cycle, quadrants of operation, speed fluctuations if any, rating etc.
- 2 Transient operation requirements
- 3 Values of acceleration and deceleration, starting, braking and reversing performance.
- 4 Requirements related to the source. Types of source and its capacity, magnitude of voltage, voltage fluctuations, power factor, harmonics and their effect on other loads, ability to accept regenerative power.
- 5 Space and weight restriction if any.
- 6 Environment and location.
- 7 Reliability

Group electric drive

This drive consists of a single motor, which drives one or more line shafts supported on bearings. The line shaft may be fitted with either pulleys and belts or gears, by means of which a group of machines or mechanisms may be operated. It is also some times called as **shaft drives**.

Advantages: The advantages of electrical drives include the following:

- These drives are obtainable with an extensive range of speed, power & torque.
- Not like other main movers, the requirement of refuel otherwise heat up the motor is not necessary.
- They do not contaminate the atmosphere.
- Previously the motors like synchronous as well as induction were used within stable speed drives. Changeable speed drives utilize a DC motor.
- They have flexible manage characteristics due to the utilization of electric braking.
- At present, the AC motors motor is used within variable speed drives because of semiconductor converters development.

Disadvantages

The disadvantages of electrical drives include the following.

- This drive cannot be used where the power supply is not accessible.
- The power breakdown totally stops the entire system.
- The primary price of the system is expensive.
- The dynamic response of this drive is poor.
- The drive output power which is obtained is low.
- By using this drive noise pollution can occur.

Applications of Electrical Drives: The applications of electrical drives include the following.

- The main application of this drive is electric traction which means transportation of materials from one location to another location. The different types of electric tractions mainly include electric trains, buses, trolleys, trams, and solar-powered vehicles inbuilt with battery.
- Electrical drives are extensively used in the huge number of domestic as well as industrial applications which includes motors, transportation systems, factories, textile mills, pumps, fans, robots, etc.
- These are used as main movers for petrol or diesel engines, turbines like gas otherwise steam, motors like hydraulic & electric.

Thus, this is all about the fundamentals of electrical drives. From the above information, finally, we can conclude that a drive is one kind of electrical device used to control the energy which is sent to the electrical motor. The drive supplies energy to the motor in unstable amounts & at unstable frequencies, thus ultimately controls the speed and torque of the motor. Here is a question for you, what are the main parts of the electric drive.

Individual electric drive

In this drive each individual machine is driven by a separate motor. This motor also imparts motion to various parts of the machine.

Multi motor electric drive : In this drive system, there are several drives, each of which serves to actuate one of the working parts of the drive mechanisms.

e.g: Complicated metal cutting machine tools
Paper making industries.

Rolling machines etc.

A modern variable speed electrical drive system has the following components

- Electrical machines and loads
- Power modulator
- Sources
- Control unit
- Sensing unit

Electrical machine

Most commonly used electrical machines for speed control applications are the following.

DC machines

Shunt, series, compound, DC motors and switched reluctance machines.

AC machines

Induction, wound rotor, synchronous, permanent magnet synchronous and synchronous reluctance machines.

Special machines

Brush less DC motors, stepper motors, switched reluctance motors are used.

Power Modulators (Controller)

Functions

- It modulates flow or power from the source to the motor is imparted speed - torque characteristics required by the load.
- During transient operation, such as starting, braking and speed reversal, it reduces the motor current within permissible limits.
- It converts electrical energy of the source into the form of suitable to the motor.
- It selects the mode of operation of the motor (i.e) motoring and braking.

Types of power modulators (Controllers)

- In the electric drive system, the power modulators can be any one of the following.
- Controlled rectifiers (AC to DC converter)
- Inverters (DC to AC converters)
- AC voltage controllers (AC to DC converters)
- DC choppers (DC to DC converters)
- Cyclo converters (Frequency conversion)

Electrical sources

Very low power drives are generally fed from single phase sources. Rest of the drives is powered from a 3-phase source. Low and medium power motors are fed from a 415V supply. For higher ratings, motors may be rated at 3.3KV, 6.6 KV and 11 KV. Some drives are powered from battery.

Sensing unit

- Speed sensing (from motor)
- Torque sensing
- Position sensing
- Current sensing and voltage sensing (from lines or from motor terminals from load)
- Temperature sensing

Control unit :Control unit for a power modulator are provided in the control unit. It matches the motor and power converter to meet the load requirements.

Block diagram of DC drive : The block diagram of a DC drive system is in Fig 3

DC drive input : Some thyristor based DC drives operate on a single phase supply and use four thyristors for full wave rectification. For larger motors 3 phase power supply is needed because the waveforms are much smoother. In such cases, six thyristors are needed for full wave rectification.

Rectifier Bridge : The power component of a controlled DC drive is a full wave bridge rectifier which can be driven by three phase or single phase supply. As mentioned above the number of thyristor may vary depends on the supply voltage.

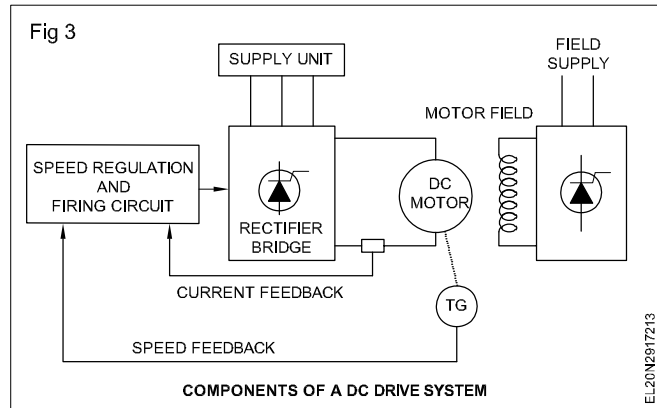

A six - thyristor bridge (in case of three phase converter) rectifies the incoming AC supply to DC supply to the motor armature. The firing angle control of these thyristors varies the voltage to the motor.

Field Supply Unit (FSU) : The power is to be applied to the field winding is much lower than the armature power.

In many cases a two - phase supply is drawn from the three phase input (that supplies power to the armature) and hence the field exciter is included in the armature supply unit.

The function of the field supply unit is to provide a constant voltage to the field winding to create a constant field or flux in the motor. In some cases, this unit is supplied with thyristors to reduce the voltage applied to the field so as to control the speed of the motor above the base speed in case of permanent magnet DC motors, the field supply unit is not included in the drive.

Speed Regulation unit : It compares the operator instruction (desired speed) with feedback signals and sends appropriate signals to the firing circuit. In analog drives, this regulator unit consists of both voltage and current regulators. The voltage regulator accepts the speed error as input and produces the voltage output which is then applied to the current regulator.

The current regulator then produces required firing current to the firing circuit. If more speed is required, additional current is drawn from the voltage regulator and hence thyristors conduct for more periods. Generally, this regulation (both voltage and current) is accomplished with proportional -integral- derivative controllers.

The field current regulator is also provided where speed greater than the base speed is required.

Parts of DC drive : DC drives of various brands with different ratings are available in the market. It is generally assembled in a metallic enclosure. The front panel has the power terminals, control terminals, keypad for controlling the drive etc. It has provision for connecting to PC for programming the drive.

The main parts of DC drive are given below. (Fig 4)

- 1 Main drive assembly
- 2 Terminal cover
- 3 Terminal cover retaining screw

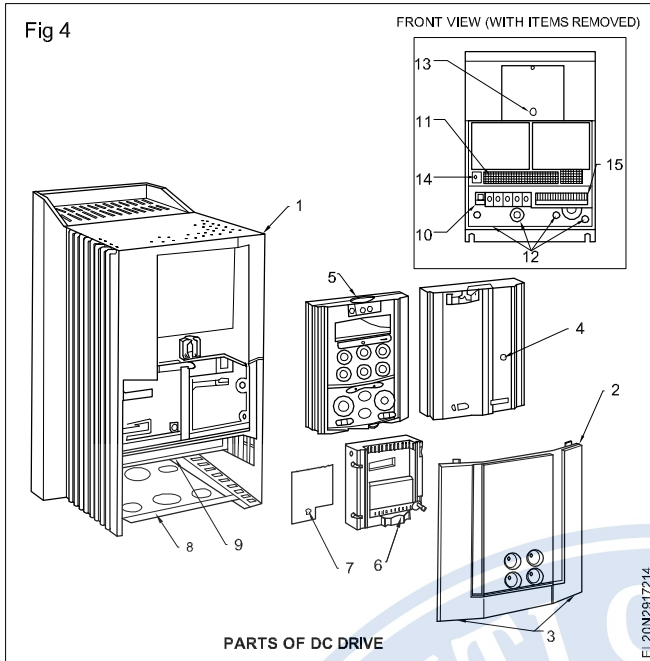

- 4 Blank cover
- 5 Keypad
- 6 COMMS technology box (optional)
- 7 Speed feedback technology card (optional)
- 8 Gland plate
- 9 Power terminal shield
- 10 Power terminals
- 11 Control terminals
- 12 Earthing / grounding points
- 13 Keypad part
- 14 Programming part
- 15 Auxiliary power, external contactor, blower and isolated thermistor terminals

Power and control terminals

In DC drive, the front panel has the power terminals L1, L2 and L3 where 3 phase input supply of 415V can be connected.

There are control terminals given for speed adjust potentiometer, Torque adjust potentiometer, START/RUN/STOP switch, JOG/RUN/ switch, AUTO/MAN switch, FORWARD/REVERSE switch etc. Terminal A1 & A2 and B₀ & B₁ are meant for armature and field connections respectively. Names and locations are illustrated in Fig 5.

Advantages of DC drive

- DC drives are less complex with a single power conversion from AC to DC.

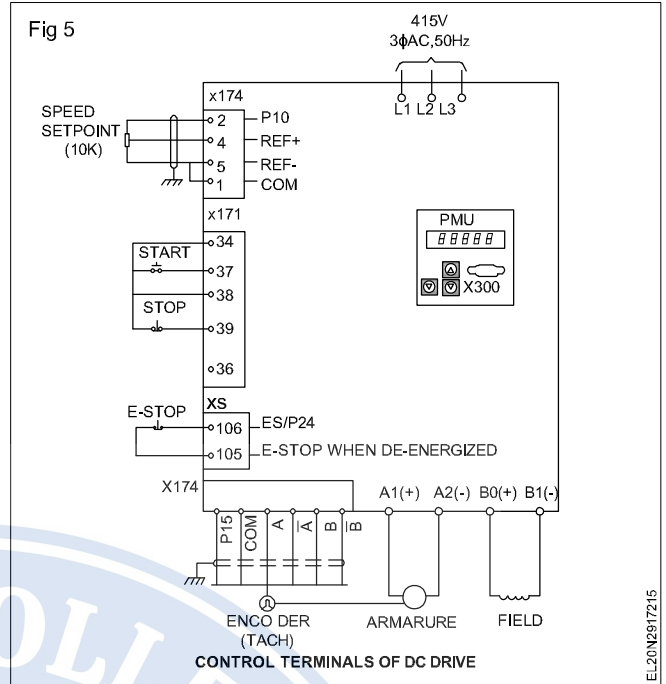

- DC drives are normally less expensive for most horsepower ratings.
- DC motors have a long tradition of use as adjustable speed machines and a wide range of options have evolved for this purpose.
- Cooling blowers and inlet air flanges provide cooling air for a wide speed range at constant torque.
- Accessory mounting flanges and kits for mounting feedback tachometers and encoders.
- DC regenerative drives are available for applications requiring continuous regeneration for overhauling loads. AC drives with this capability would be more complex and expensive.
- Properly applied brush and commutator maintenance is minimum.
- DC motors are capable of providing starting and accelerating torques in excess of 400% of rated value.
- Some AC drives may produce audible motor noise which is undesirable in some applications.

Disadvantages of DC drive

- More complicated because of commutators and brushes.
- Heavier than AC motors.
- High maintenance is required.
- Large and more expensive than AC drive.
- Not suitable for high speed operation.

Speed control of 3 phase induction motor by VVVF/AC drive

Objectives: At the end of this lesson you shall be able to

- state about AC drives (VFD/VVFD) and changing of speed of AC motor by AC drive
- explain the operation of AC drive with block diagram
- list out the advantages and disadvantages of AC drive
- explain the components / parts and power and control terminals of AC drive
- state the parameter setting - speed control changes of direction of AC & DC drives / VFD/VVFD (variable frequency drive/ variable voltage variable frequency drive)
- state the speed control of universal motor.

Variable Voltage Variable Frequency Drive (VVVFD)

The AC drive industry is growing rapidly and it is now more important than ever for technicians and maintenance personnel to keep AC drive installations running smoothly. AC drives change the speed of AC motor by changing voltage and frequency of the power supplied to the AC motor. In order to maintain proper power factor and reduce excessive heating of the motor, the name plate volts / hertz ratio must be maintained. This is the main task of VFD (Variable frequency drive).

Applications of AC drives

- 1 AC drives are used to stepless speed control of squirrel cage induction motors mostly used in process plants due to its ruggedness and maintenance free long life.
- 2 AC drives control the speed of AC motor by varying output voltage and frequency through sophisticated microprocessor controlled electronics device.
- 3 AC drive consists of rectifier and inverter units. Rectifier converts AC to DC voltage and inverter converts DC voltage back to AC voltage.

Changing of speed of AC motors by using AC drive

From the AC motor working principle, that the synchronous speed of motor N_s in rpm, is dependent upon frequency. Therefore by varying the frequency of the power supply through AC drive, it can control the synchronous speed.

Speed (rpm) = Frequency (Hertz) x 120 / No. of poles.

Where

Frequency = Electrical frequency of the power supply in Hz., No. of poles = Number of electrical poles in the motor stator. Thus the speed of AC motor can conveniently be adjusted by changing the frequency applied to the motor. There is also another way to make the AC motor work on different speed by changing the no. of poles, but this change would be a physical change of the motor. The VFD provides the controls over frequency and voltage of motor input to change the speed of a motor. Since the frequency is easily variable as compared with the poles variation of the motor. AC drives are frequently used.

Constant V/F ratio operation

If the same voltage is applied at the reduced frequency, the magnetic flux would increase and saturate the

magnetic core, significantly distorting the motor performance. The magnetic saturation can be avoided by keeping the ϕ_m constant.

All AC drives maintain the voltage -to- frequency (V/F) ratio constant at all speeds for the reason that follows. The phase voltage V, frequency F and the magnetic flux ϕ of motor are related by the equation.

$$V = 4.444 f N \phi_m$$

or

$$V/f = 4.444x N \phi_m$$

Where N = number of turns per phase

ϕ_m = magnetic flux

Moreover, the AC motor torque is the product of stator flux and rotor current. For maintaining the rated torque at all speeds the constant flux must be maintained at its rated value, which is basically done by keeping the voltage - to - frequency (V/f) ratio constant.

Block diagram of AC drive

The Insulated - Gate - Bipolar- Transistor (IGBT) is in the past two decades come to dominate VFD as an inverter switching device.

IGBTs (insulated gate bipolar transistor) provide a high switching speed necessary for PWM (Pulse width Modulation) inverter operation. IGBTs are capable of switching ON and OFF several thousand times a second. An IGBT can turn on in less than 400 nanoseconds and off in approximately 500 nanoseconds. An IGBT consists of a gate, collector and an emitter. When a positive voltage (typically +15 VDC) is applied to the gate the IGBT will turn on. This is similar to closing a switch. Current will flow between the collector and emitter.

An IGBT is turned off by removing the positive voltage from the gate. During the off state the IGBT gate voltage is normally held at a small negative voltage (-15 VDC) to prevent the device from turning on. So the gate can control the switching on/off operation of an IGBT.

Fig 1 shows the block diagram of AC drive and Fig 2 shows the internal connection diagram. There are three basic sections of the AC drive; the rectifier, DC bus, and inverter.

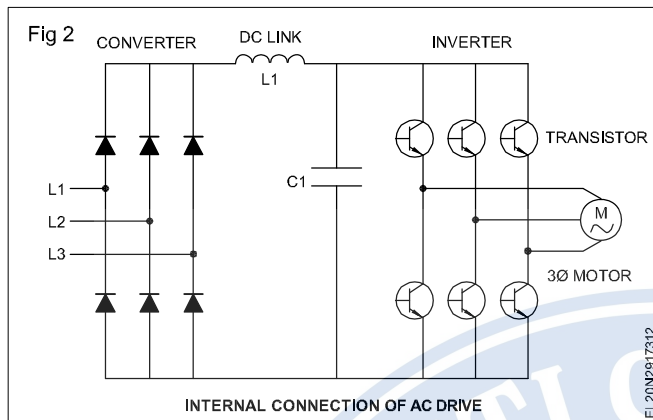
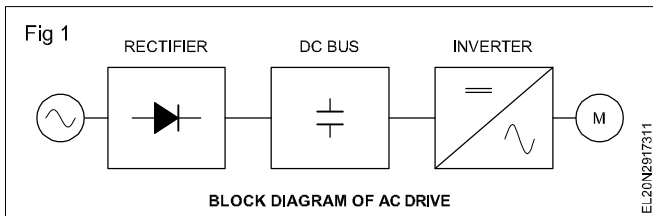

The rectifier in an AC drive is used to convert incoming AC power into direct current (DC) power. Rectifiers may utilize diodes, silicon controlled rectifiers (SCR), or transistors to rectify power. An AC drive using transistors in the rectifier section is said to have an “active front end.”

After the power flows through the rectifiers it is stored on a DC bus. The DC bus contains capacitors to accept power from the rectifier, store it, and later deliver that power through the inverter section. The DC bus may also contain inductors, DC links, chokes, or similar items that add inductance, thereby smoothing the incoming power supply to the DC bus.

Inverter : An inverter is a device which converts DC into AC. The inverter contains transistors that deliver power to the motor. The “Insulated Gate Bipolar Transistor” (IGBT) is a common selection in modern AC drives. The IGBT can switch on and off several thousand times per second and precisely control the power delivered to the motor. The IGBT uses a method named “Pulse Width Modulation” (PWM) to simulate a current sine wave at the desired frequency to the motor.

Advantages and disadvantages of AC drive

Advantages

- They use conventional low cost 3 phase AC induction motors for most applications
- AC motors require virtually no maintenance and are preferred for application where the motor is mounted in an area not easily reached for servicing or replacement.
- AC motors are smaller, lighter, more commonly available and less expensive than DC motors.
- AC motors are better suited for high speed operation (over 2500 rpm) since there are no brushes, and commutation is not a problem.

- Whenever the operating environment is wet, corrosive or explosive, special motor enclosures are required. Special AC motor enclosure types are more readily available at lower prices.
- Multiple motors in a system must operate simultaneously at a common frequency/speed.

Disadvantages

- A standard motor can not adequately cool its winding at slow speed or handle the irregular electrical waveform from the AC drive.
- An AC drive requires installation of motor with heavier windings.
- AC drive has complicated electronics circuit, so fault rectification is costly.
- AC drives produce a simulated waveform, not a perfect sine wave. That degrade the power equality.

Components of AC drive

A variable frequency drive is a device used in a drive system consisting of the following three main sub-systems. AC motor, main drive controller assembly, and drive / operator interface as in Fig 3.

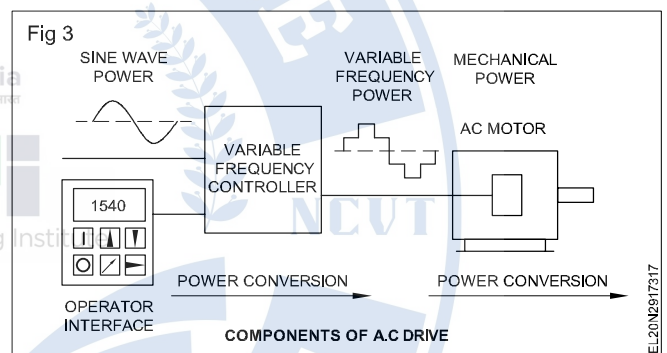

AC motor

The AC electric motor used in a VFD system is usually three - phase induction motor. Some types of single - phase motors can be used, but three - phase motors are usually preferred. Various types of synchronous motors offer advantages in some situations, but three - phase induction motors are suitable for most purposes and are generally the most economical motor choice. Motors that are designed for fixed - speed operation are often used. Elevated - voltage stresses imposed on induction motors that are supplied by VFDs require that such motors are designed for definite - purpose inverter-fed duty.

Controller : The VFD controller is a solid - state power electronics conversion, system consisting of three distinct sub-systems, a rectifier bridge converter, a direct current (DC) link, and an inverter. Voltage - source inverter (VSI) drives are the most common type of drives. Most drives are AC to AC drives in that they convert AC line input to AC inverter output. However, in some applications such as common DC bus or solar applications, drives are configured as DC-AC drives. The most basic rectifier converter for the VSI drive is configured as a three -phase, six -pulse, full-wave diode bridge.

In a VSI drive, the DC link consists of a capacitor which smooths out the converter's DC output ripple and provides a stiff input to the inverter. This filtered DC voltage is converted to quasi-sinusoidal AC voltage output using the inverter's active switching elements. VSI drives provide higher power factor and lower harmonic distortion than phase- controlled current - source inverter (CSI) and load - commutated inverter (LCI) drives.

In variable -torque applications suited for volts - per- Hertz (V/Hz) drive control. AC motor characteristics require that the voltage magnitude of the inverter's output to the motor be adjusted to match the required load torque in a linear V/Hz relationship. For example, 415V, 50Hz motors, this linear V/Hz relationship is $415/50=8.3\text{V/Hz}$.

Although space vector pulse- width modulation (SVPWM) is becoming increasingly popular, sinusoidal PWM (SPWM) is the most straight forward method used to vary drives motor voltage (or current) and frequency. With SPWM control quasi- sinusoidal, variable - pulse-width output is constructed from intersections of a saw-toothed carrier signal with a modulating sinusoidal signal which is variable in operating frequency as well as in voltage (or current).

An embedded microprocessor governs the overall operation of the VFD controller. Basic programming of the microprocessor is provided as user - inaccessible firmware. User programming of display, variable, and function block parameters is provided to control, protect, and monitor the VFD, motor, and driven equipment.

Operator interface

The operator interface provides a means for an operator to start and stop the motor and adjust the operating speed. Additional operator control functions might include reversing, and switching between manual speed adjustment and automatic control from an external process control signal. The operator interface often includes an alphanumeric display and/or indication lights and meters to provide information about the operation of the drive.

An operator interface keypad and display unit is often provided on the front of the VFD controller shown in the Fig 3. The keypad display unit can often be cable - connected and mounted a short distance from the VFD controller. They are also provided with input and output (I/O) terminals for connecting push buttons, switches, and other operator interface devices or control signals. A serial communications port is also often available to allow the VFD to be configured, adjusted, monitored, and controlled using a computer.

Operation of AC drive

When the VFD is started the applied frequency and voltage are increased at a controlled rate or ramped up to accelerate the load. This starting method typically allows a motor to develop 150% of its rated torque while the VFD is drawing less than 50% of its rated current from the mains in the low - speed range. A VFD can be adjusted to produce a steady 150% starting torque from standstill

right up to full speed. However, motor cooling deteriorates and can result in overheating as speed decreases such that prolonged low -speed operation with significant torque is not usually possible without separately motorized fan ventilation.

With a VFD, the stopping sequence is just the opposite as the starting sequence. The frequency and voltage applied to the motor are ramped down at a controlled rate. When the frequency approaches zero, the motor is shut off. Additional braking torque can be obtained by adding a braking circuit (resistor controlled by a transistor) to dissipate the braking energy.

Part of AC drive (Fig 4a & 4b)

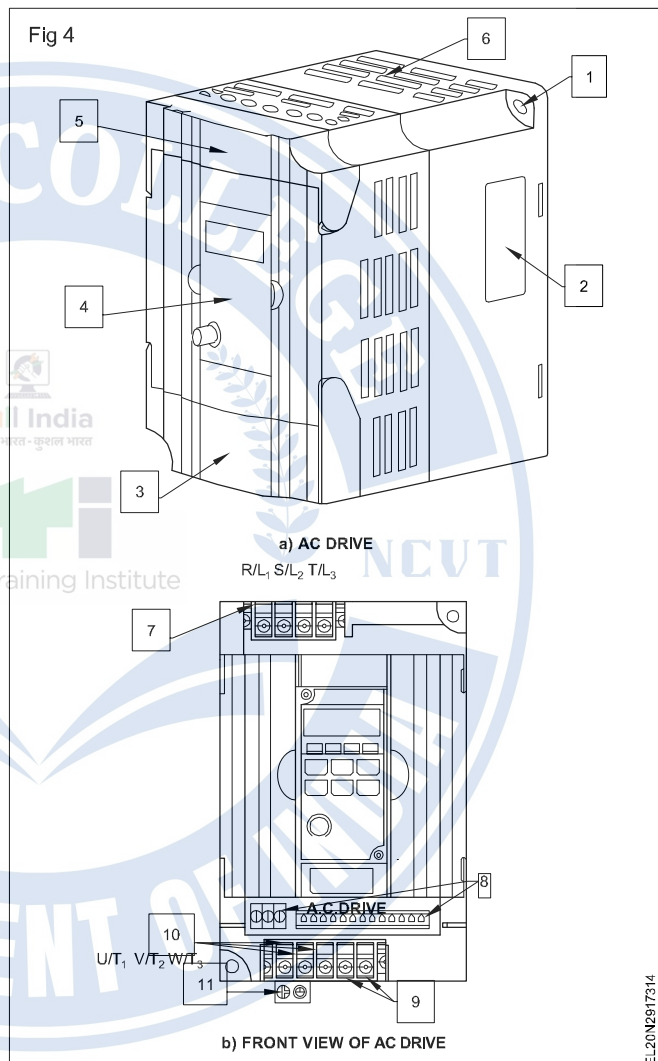

AC drives of various brand with different ratings are available in the market. It is generally assembled in a metallic enclosure. The front panel has the power input and output terminals, control terminals, keypad (operator interface) for controlling the drive etc. It has provision for connecting to PC for programming the drive.

The main parts are given below and shown in Fig 4a and 4b.

- 1 Mounting screw holes
- 2 Name plate label

- 3 Bottom cover
- 4 Digital keypad
- 5 Upper cover
- 6 Ventilation hole
- 7 Input terminals
- 8 Control Input/Output terminals
- 9 External brake resistor terminal
- 10 Output terminals
- 11 Grounding

Power and control terminals

In AC drive, the front panel has the input power terminals viz R/L₁, S/L₂ and T/L₃ where 3 phase AC 415V, 50Hz supply is connected. The 3 phase induction motor is connected of output power terminals viz. U/T1, V/T2 and W/T3.

There are control terminals viz M0, M1, M2, M3, GND, +10V, AV1 etc. for starting/stopping/ reversing and speed control actions. Names and locations are given in Fig 5

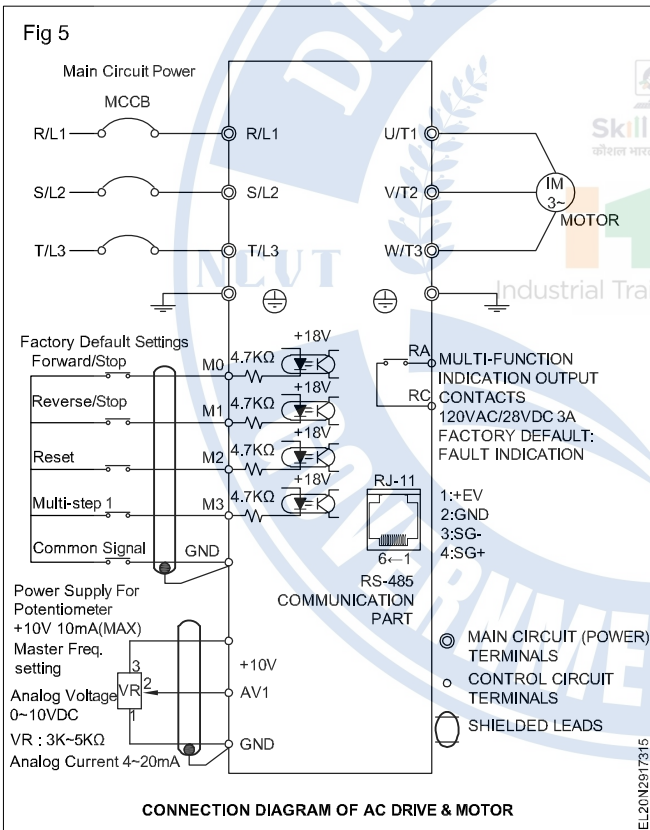

Parameter settings of DC drive

As discussed in previous chapter, the speed of DC motor is directly proportional to the armature voltage (E_b) and inversely proportional to the field current (I_f) and also the armature current (I_a) is proportional motor torque.

In armature controlled DC drives, the drive unit provides a rated current and torque at any speed up to rated speed.

The Fig 6 shows **Basic Operator Panel (BOP)** keypad provided on the front panel meant for controlling the drive.

Fig 6

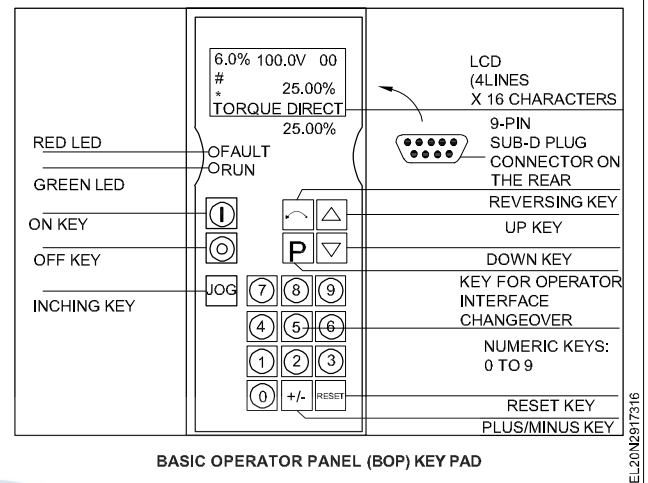

The LCD is used to monitor the parameter. To start the motor, 'ON' key is to be pressed, and to stop the motor 'OFF' key is to be pressed. There is 'JOG' key provided for inching operation.

There is a key 'P' given for operator interface, changing over the parameter setting can be done by using this key in association with (Δ) key and key (∇). Parameters like, voltage current, Torque etc will be displayed turn by turn on each pressing of 'P' key /button.

The (Δ) or (∇) keys are used to increase or decrease the values. Numeric keys are also can be used to enter the values directly.

LED indicators are provided to indicate the status of drive. Green LED indicates the system running where as Red LED indicates when fault is occurred.

Programming of DC drive is possible through, personal computer (PC) also. For this purpose a connector for connecting PC through interfacing cable is provided at the rear panel.

There may be variations in terms of names of key, display setting etc for different brands.

Operation of motor through DC drive

Fig 7 shows the operation of controls arrangement which is called as basic operator panel (BOP) .

The input supply connections and armature and field connections are well illustrated in Fig 7. Input 3 phase AC, 415V, 50Hz supply can be connected L₁, L₂ and L₃. The armature is connected across A₁ and A₂ where as the field is connected across B₀ and B₁ (The terminal names may vary depends on the type and make) an equipment ground conductor (Ground wire) must be connected to the controller mounting panel. Separate equipment grounding conductors from other major components Viz, motor, drive enclosure isolation transformer case (if used) in the system must also be connected continuously to a control connection point.

The AC input supply is provided should match the voltage and frequency given on the controller's name plate. Improper voltage may damage the equipment and insufficient current will cause erratic operation of the drive.

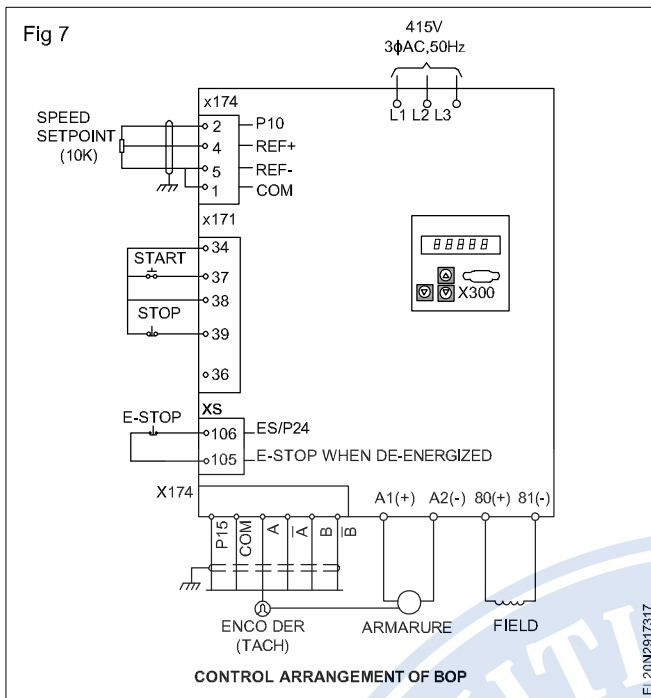

The shielded cable is recommended for the tachometer and all low level signal circuit to eliminate the possibility of electrical interference.

In some DC drives a speed adjusting potentiometer is provided to vary motor speed by controlling armature input voltage after the controller has been started. Some time a torque adjusting potential meter is used in place of speed adjusting potentiometer. It controls motor torque by controlling the DC current in the motor armature.

Starting and controlling the speed of DC motor

When the 'ON' button in BOP is pressed, the motor will start running. The desired speed can be attained by using 'P' button and Δ & ∇ buttons.

When the "OFF" button is pressed the motor will stop but AC line voltage remains connected to the controller and full field voltage is present. Armature voltage is reduced to zero. When pressing the "ON" button again the motor will accelerate to the preset speed.

Inching operation

For inching operation the 'JOG' position should be selected. Then the controller will operate only as long as the "ON" button is held pressed.

Changing the direction of rotation

In some model a 'reversing switch' is provided to change the direction of rotation of the motor. This switch is responsible for changing the polarity at the motor armature connection. First start the motor by pressing 'ON' button. The motor will run in forward direction. To change the direction of rotation, press "OFF" button and ensure that the motor is completely stopped. Now press the reversing button and then press the "ON" button. The motor will now run in the reverse direction. The reversing key has a provision which prevents direct transfer from one direction to the other.

Precautions during installation, connection and operation of DC drive

- Ensure all screws are tightened to the proper torque rating.
- During installation, follow all local electrical and safety codes.
- Ensure that appropriate protective devices (circuit breaker MCB or fuses) are connected between the power supply and DC drive.
- Make sure that the drive is properly earthed.
- Do not attach or remove wiring when power is applied to the DC drive.

Parameter setting of AC drive

As explained earlier the speed (N) of AC induction motor is directly proportional to the voltage (V) and frequency (f) of the applied power supply. Within the base speed limit, the torque (T) can be kept constant by maintaining a constant voltage / frequency (V/F) ratio. By increasing of speed to above base speed limit is also possible but at the cost of the torque.

(VFD /VVVFD (Variable Voltage Variable Frequency Drive) drives are used for efficient speed control of AC motors. The advantages of using drives to control the speed is already explained.

The AC drive has a front panel which includes two parts. Display panel and keypad. The display panel is provided with the parameter display and shows operation status of the AC drive. Keypad provides programming interface between users and AC drives. The Fig 8. shows the location of buttons and display unit on the front panel of AC drive.

Mode /Reset button

By pressing this button repeatedly the display will show status at the AC drive such as the reference frequency and output current. If the drive stops due to a fault, correct the fault first, then press this button to reset the drive.

Prog/Data button

By pressing this button will store the entered data or can show factory stored data.

Run/Stop button

To 'start' or 'stop' the AC drive operation this button is to be pressed.

This button can only be used to 'stop' the AC drive, when it is controlled by the external control terminals.

UP Δ / down ∇ button

By pressing the 'Up' or 'Down' button momentarily parameter setting can be changed. These key may also be used to scroll through different operating values or parameters. Pressing the 'Up' or 'Down' button momentarily it will change the parameter setting in single unit increments. To quickly run through the range of settings, press 'Down' and hold the button.

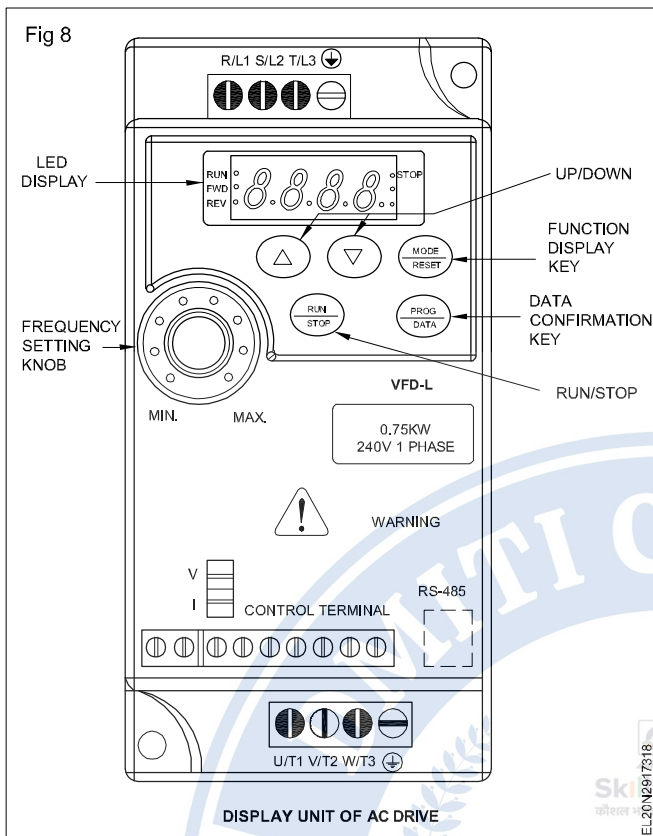

Frequency setting knob

By using this knob, the frequency variation can be done.

'RS 485' communication port

Programming of AC drive can be done through personal computer (PC) also. For this, the drive should be interfaced with PC through 'RS 485' port.

LED displays are also given in the display unit to indicate the status of drive like 'RUN', 'FWD' and 'REV'.

Operation of AC motor through drive

The motor and drive connections are well illustrated in Fig 9. A 3ϕ , 415V, 50Hz AC supply is connected to the drive input terminals R/L₁, S/L₂ & T/L₃. Similarly output terminals of this drive is such as U/T₁, V/T₂ & W/T₃ are connected to 3 phase induction motor. (The terminal names may vary depends on the type and make)

Both input end and output ends are earthed separately.

Changing of speed

The AC input supply provided, should match the voltage and frequency given on the nameplate. Improper voltage may damage the drive.

Programming can be done through 'MOD/RESET' button in association with Δ and ∇ button and the drives speed can be changed by using these buttons. The drive is started through 'RUN'/STOP' button.

The motor can be run at different speed by programming for the required speed.

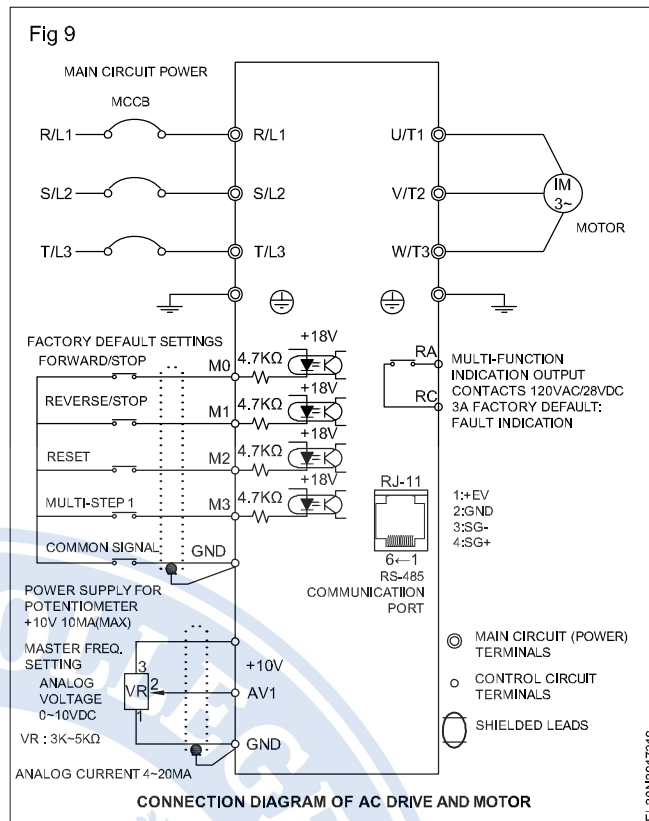

Speed control of universal motors using SCR : Majority of domestic appliances like electric drilling machine, mixer etc., incorporate universal electric motors. Any of the half wave or full wave controls discussed earlier can be used to control speed of universal motors. Universal motors have some unique characteristics which allow their speed to be controlled very easily and efficiently with a feedback circuit is in Fig 10.

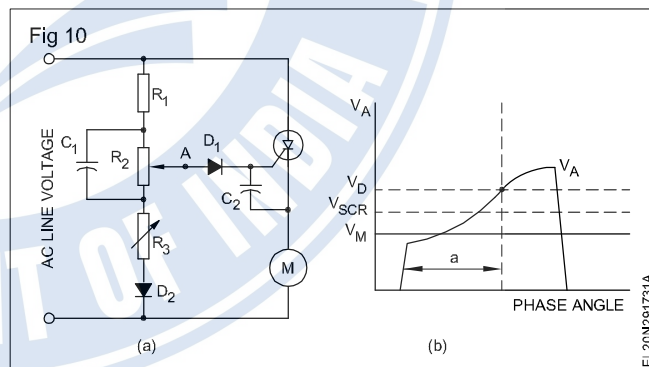

The circuit at Fig 10a provides phase controlled half wave power to the motor; that is, one the negative half cycle, the SCR blocks current flow in the negative half cycle, the SCR blocks current flow in the negative direction causing the motor to be driven by a pulsating direct current whose amplitude is dependent in the phase control of the SCR. The operation of the circuit shown in Fig 10 is as follows.

- Assuming that the motor is running, the voltage at point A in the circuit must be larger than the forward drop of diode D₁, the gate to cathode drop of the SCR, and the emf generated by the residual mmf in the motor, to get sufficient forward flow to trigger the SCR.

- The wave form at point A (V_A) for one positive half cycle is in Fig 10b and with V_{SCR} , V_D and motor generated emf V_M . The phase angle at which the SCR would trigger is shown by the vertical dotted line.
- For any reason if the motor speed increases, then V_M will increase, the trigger would move upwards and to the right along the curve so that the SCR would trigger later in the half - cycle thus providing less power to the motor, causing it to slow down. Similarly, if the motor speed decreases, the trigger point will move to the left and down the curve, causing the SCR to trigger earlier in the half cycle providing more power to the motor thereby speeding it up.
- Resistors R_1 , R_2 , R_3 along with diode D_1 and C_1 forms a ramp generator. Capacitor C_1 is charged by the voltage divider R_1 , R_2 and R_3 during the positive half cycle. Diode D_2 prevents negative current flow during the negative half cycle, therefore C_1 discharges through R_2 and R_3 during negative half cycle. Varying the value of R_2 varies the trigger angle α .

A practical version of the circuit for controlling the speed of universal motors is in Fig 11.

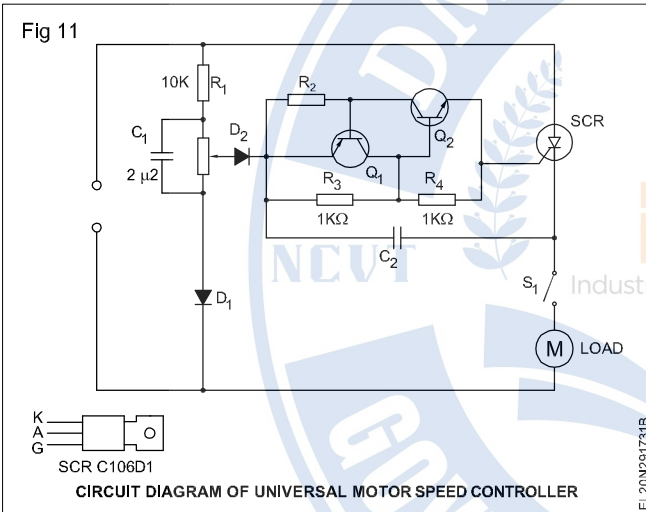

As can be seen, the circuit at Fig 11 is quite similar to that at Fig 10 but for the addition of two transistors and a few resistors.

In Fig 11, the action of Q_1 - Q_2 is to provide adequate gate current to trigger the SCR into conduction.

Q_1 - Q_2 and their associated resistors acts as a voltage sensitive switch. In each half cycle, C_2 is able to charge via R_1 . As soon as voltage across C_2 rises to suitable value. Q_1 and Q_2 both switch- on and partially discharge C_2 into the gate of the SCR, thus delivering a pulse of high current to the SCR gate, independent of any current drive limitations of RV1. The Q_1 - Q_2 and C_2 network thus enables virtually any SCR to be used in the circuit almost irrespective of its sensitivity characteristics.

The universal motor speed control circuit is in Fig 11 enables the motor speed to be smoothly varied from zero to 75% of maximum via a single control. It also incorporates built - in feedback compensation to maintain the motor speed virtually constant at any given speed setting, regard-less of load changes.