

**Practice installation of insulators used in HT/LT lines for a given voltage range**

**Objectives:** At the end of this exercise you shall be able to

- identify the type of HT/LT line insulators
- install the shackle type insulator on HT over head line
- install the pin type insulator on LT over head line.

Requirements	
<p><b>Tools/Instruments</b></p> <ul style="list-style-type: none"> <li>• Insulated combination plier 200 mm - 1 No.</li> <li>• DE spanner set 6mm to 25 mm - 1 Set.</li> <li>• Adjustable spanner 6mm to 25 mm - 1 Set.</li> <li>• Safety belt - 1 No.</li> <li>• Wooden or nylon mallet 1/2 kg - 1 No.</li> <li>• Ladder 6m long</li> <li>• Jute rope of 25 mm dia and 15 m length - 1 No.</li> <li>• Wire stretcher 25 mm - 1 No.</li> <li>• Megger 500 V - 1 No.</li> </ul>	<p><b>Materials</b></p> <ul style="list-style-type: none"> <li>• Shackle insulator, porcelain 1kV - 4 Nos.</li> <li>• Pin insulator, porcelain 1kV - 2 Nos.</li> <li>• Suspension insulator - 1 No.</li> <li>• Strain insulator - 1 No.</li> <li>• Ring insulator - 1 No.</li> <li>• Stay/egg insulator - 1 No.</li> <li>• Cotton waste - as reqd.</li> <li>• Binding wire 14 SWG aluminium - as reqd.</li> <li>• Scrap piece of ACSR conductor of length 1m (for bow) - 3 pieces</li> <li>• Sandpaper or emery sheet - as reqd.</li> <li>• Flat aluminium tape - as reqd.</li> <li>• Protective grease suitable to apply over the ACSR line conductor - as reqd.</li> <li>• Line accessories - as reqd.</li> </ul>

**PROCEDURE**

**TASK 1 : Identify the LT and HT types of insulators**

1 Identify the LT and HT type line insulators from Figures 1 to 6.

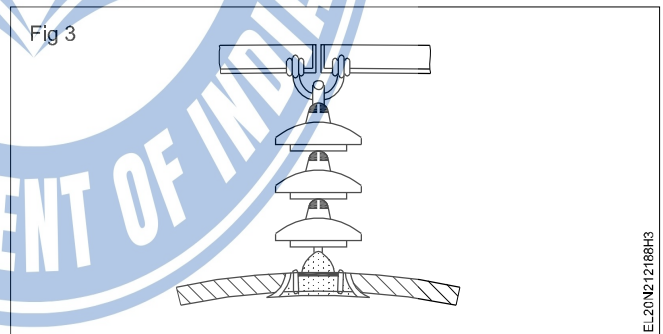
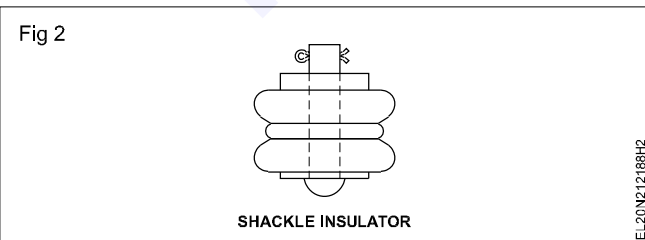
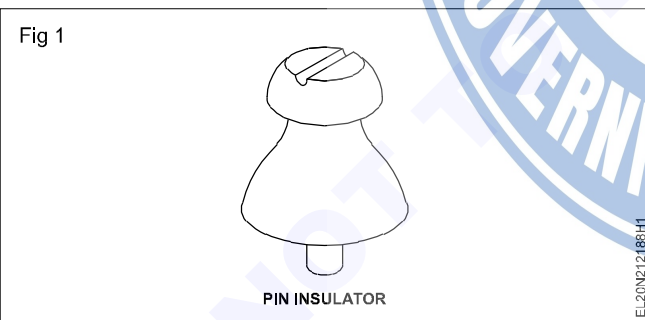

2 Write their names with voltage range and purpose in Table 1.

3 Get it checked with your instructor.

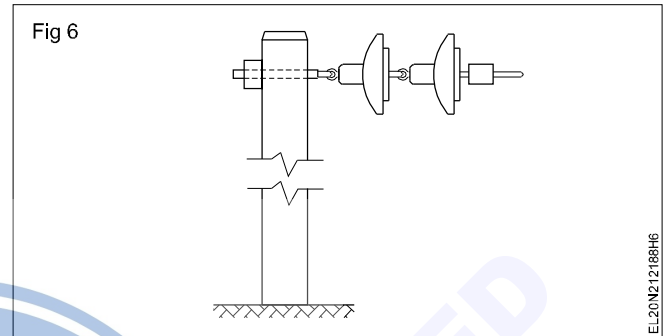
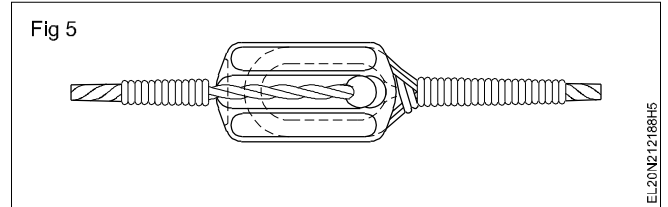
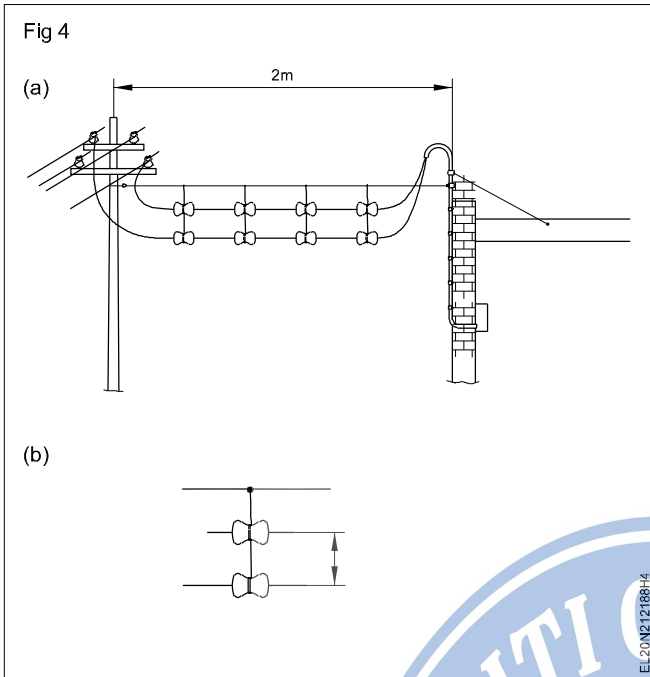

Table 1

SI.No	Name of the Insulator	Voltage range	Purpose of insulator
1			
2			
3			
4			
5			
6			

**TASK 2 : Install the shackle insulator in HT**

**Take shutdown if the nearest lines are energised. Use a safety belt while working on a pole.**

**Before starting the work check the ladder, safety belt and all the connected accessories.**

- 1 Fasten the safety belt, lay the ladder on the pole.
- 2 Release the conductor from the reel, measure the actual span plus sag and binding. Keep two lengths of conductor. (Length of span + 1ft. Sag)
- 3 Check the shackle insulator for its damage and select a good one. (Clean and carbonize etc.)
- 4 Check the assembly of the shackle insulator for its proper fitting.
- 5 Ask the helper to hold the ladder, climb up the ladder with the guide rope and spanner set.

**While working on the ladder, the ladder should be held by a helper to avoid slipping.**

- 6 Position yourself conveniently on the cross-arm, tie the safety belt end to the cross-arm. Send one end of guide rope to the helper and ask him to tie to the shackle assembly and lift it to the top.
- 7 Fix the shackle insulator to the cross-arm by 'C' clamps. (Fig 1)

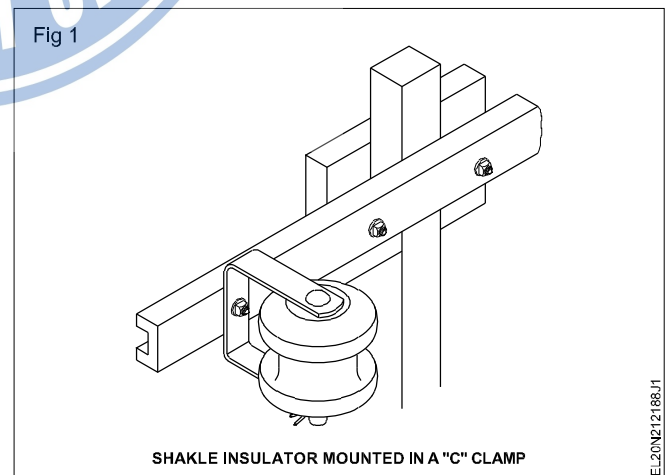

- 8 Get the draw pulley from the ground and secure it on the cross-arm. Interlace the rope through the pulley and send the other end to the helper.
- 9 Ask the helper to properly tie the O.H. conductor to the rope and lift the conductor to the cross-arm position.

**While lifting the conductor both the end conductors should be lifted at a time first, and then middle conductors to avoid the fitting of the cross-arm.**

**While tying, the conductor to the rope the helper should leave at least 1 metre length of conductor free at the end from binding.**

- 10 Twist the end portion of the conductor over the main line conductor. (Fig 2)

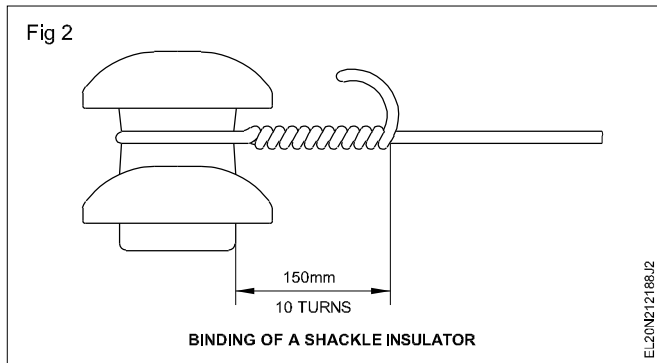

- 11 Bind the shackle insulators with the one fixed at the last cross - arm.

**Ground clearance of overhead conductor should not be less than 4.572 m for low and medium voltage.**

- 12 Get down from the pole after checking the binding.

### TASK 3 : Install the pin type insulator in LT

- 1 Climb the next pole following the previous procedure
- 2 Lift the conductor and keep it on the pin insulator. Ask the other helper to lift and stretch the conductor with wire stretcher.
- 3 Fix the pin insulator to the cross - arm of the existing pole.

**If the span is less, there is no need to use a draw pulley, pulling with the help of a rope is sufficient.**

- 4 Bind the pin insulators as per procedure.

**The binding wire must be of the same metal as the line wire.**

**Binding should be mechanically strong.**

- 5 Bind the free ends of the binding conductor over the line conductor tightly in the opposite direction. (Fig 1)

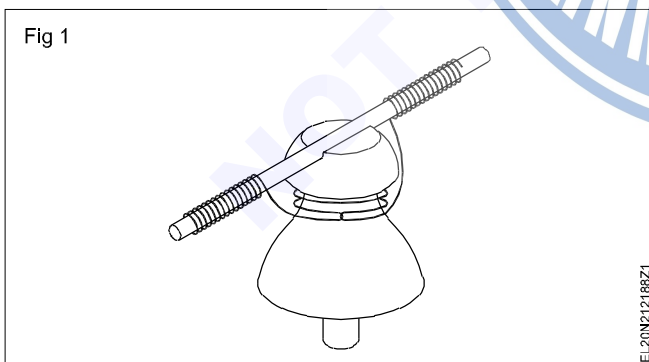

**Binding should be tight without any gap.**

**Alternatively the conductor can be placed in the side groove for binding the conductor with the pin insulator as in Fig 2.**

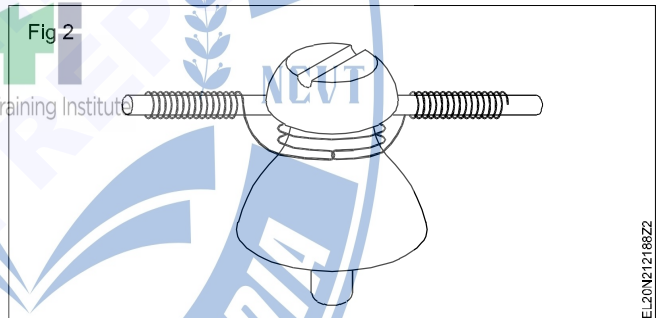

- 6 Complete the binding by giving about 15 turns on both sides.

- 7 Cut the extra binding wire and round off the raised ends.

- 8 Repeat the procedure for the other pin insulator by the side of the same cross arm.

**Check the bindings before getting down. No tool and wire should be left on the cross-arm.**

- 9 Test by a Megger of 500 Volt for insulation between conductors and insulation resistance between conductors and earth. Enter in Table 1.

Table 1

**Test results**

Sl.No.	Measurement between	Insulation value
1	Insulation resistance between conductors	Megohm
2	Insulation resistance between first conductor and earth	Megohm
3	Insulation resistance between second conductor and earth	Megohm

**The distribution lines shall be charged only when the megger test is satisfactory. It must be a minimum of 1M $\Omega$  and above for medium voltage lines.**

10 Climb on the first pole and tie the jumpers for extending connections to the existing supply line to the new erected line. Carry out the same procedure for other conductor also.

**Verify before touching any overhead line whether the line is dead and all the safety measures are followed.**

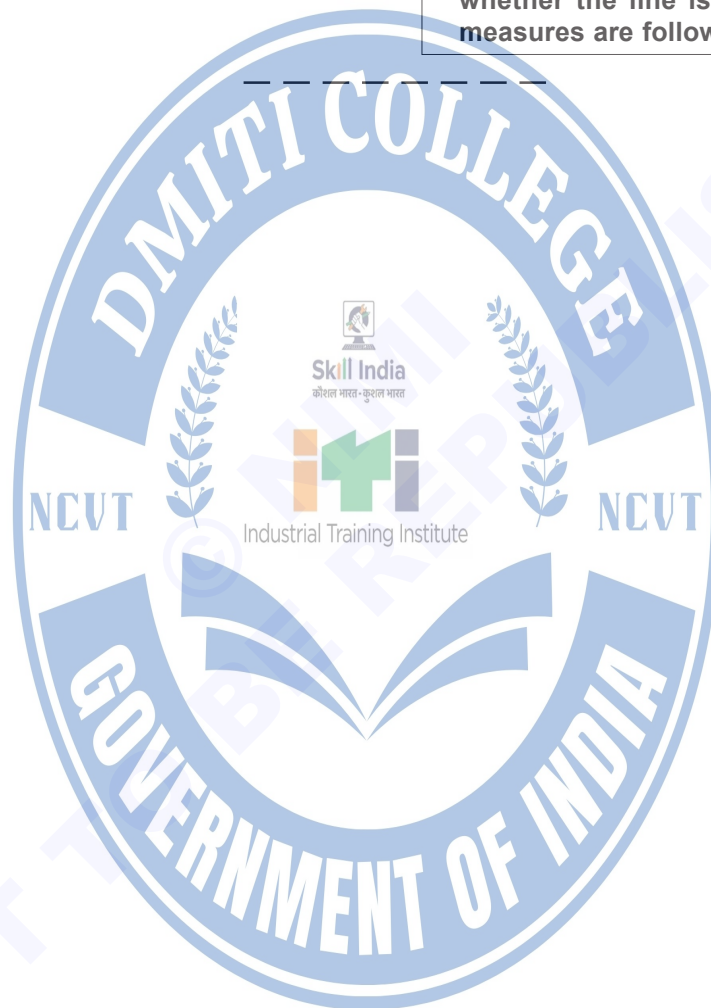

**Draw single line diagram of transmission and distribution system**

**Objectives:** At the end of this exercise you shall be able to

- visit and trace the transmission and distribution system
- identify the equipments in sequential stages of transmission and distribution system
- prepare the layout and draw the single line diagram of the transmission and distribution system.

Requirements			
<b>Tools/Equipment /Material</b>			
• Drawing sheet	- 1 No.	• Eraser	- 1 No.
• Pencil (HB)	- 1 No.	• Scale-300mm	- 1 No.

**PROCEDURE**

**The instructor may take the trainees to the nearest transmission and distribution line system and explain the name of the equipment, their specification and function also instruct the trainees to follow the safety regulation while visiting the substation.**

- 1 Visit the transmission and distribution line system and power plant.
- 2 Identify the sequential stages of transmission and distribution line system.
- 3 Trace and identify the various equipments like transformers, feeders, circuit breakers, Isolator, CT and PT etc, from the generation to the consumer points in sequence of transmission and distribution system.
- 4 Note down the earthing system. Note the different values of earth resistance displayed in the earth pit.
- 5 Note down their details in Table 1 (Name, Specification and functions) for transmission system and for distribution system.
- 6 Locate the places of equipments and draw the single line diagram of transmission and distribution system. Which you have visited.

Table 1  
**Transmission system**

Sl.No	Name of the equipment	Specification	Function
1			
2			
3			
4			
5			
6			
7			
8			

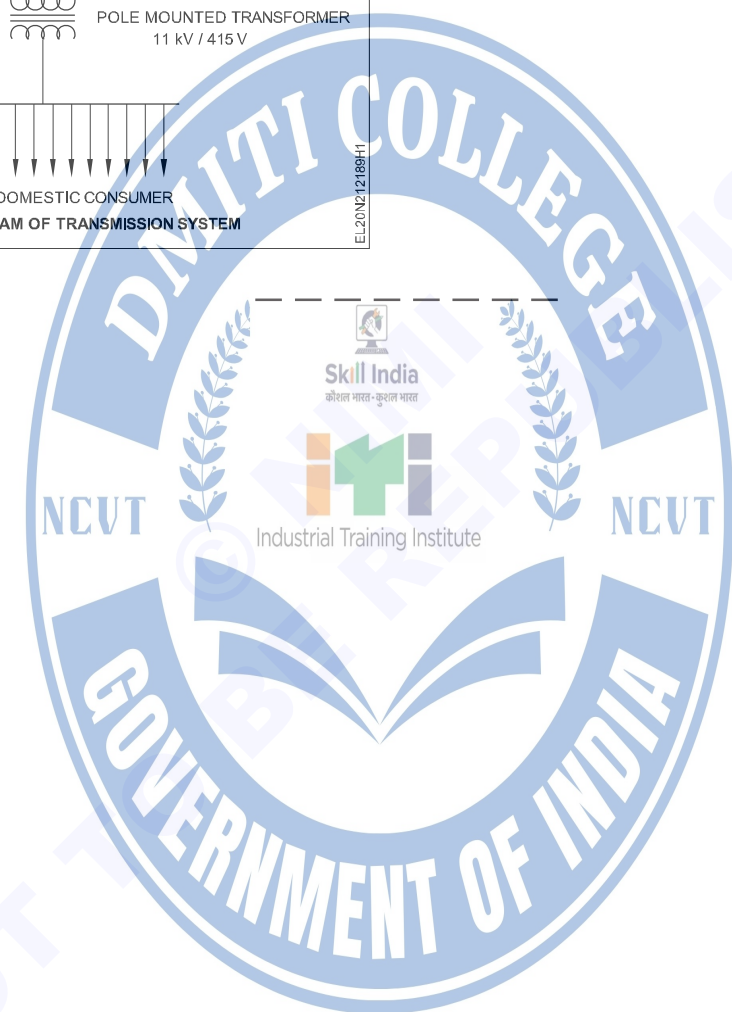
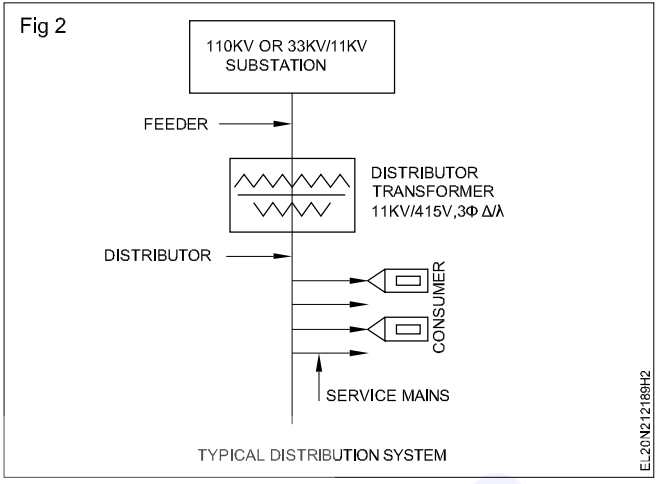
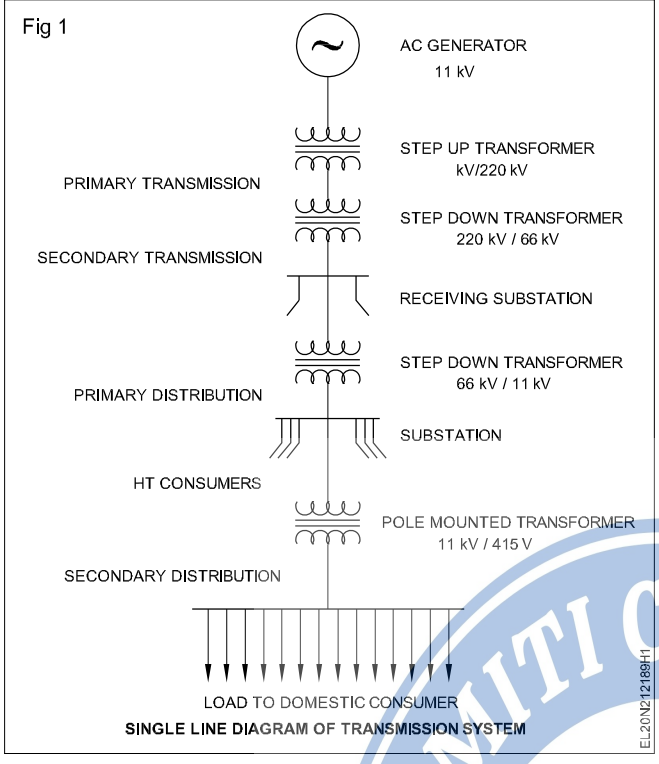

**Measure current carrying capacity of conductor for given power supply**

**Objectives:** At the end of this exercise you shall be able to

- identify and select 3 different conductors i.e. copper, aluminium and alloy
- connect the circuit and measure the breaking current of the conductor.

Requirements	
Tools/Instruments/Equipment	Material
<ul style="list-style-type: none"> <li>• Trainees tool kit - 1 No.</li> <li>• Ammeter M.C. 0-10A - 1 No.</li> <li>• Voltmeter M.C. 0-15V - 1 No.</li> <li>• Rheostat 270Ω 2A - 1 No.</li> <li>• Lead acid battery 12V 60AH - 1 No.</li> </ul>	<ul style="list-style-type: none"> <li>• Wooden board with switch 16A 250V - 1 No.</li> <li>• 32 SWG copper conductor, aluminium conductor and alloy conductor - 10 cm</li> <li>• Connecting wires 2.5 sq.mm copper - as reqd.</li> </ul>

**PROCEDURE**

- 1 Select 32 SWG copper conductor, aluminium conductor and alloy conductor of 10 cm length each.
- 2 Connect it on the test board. (Fig 1)

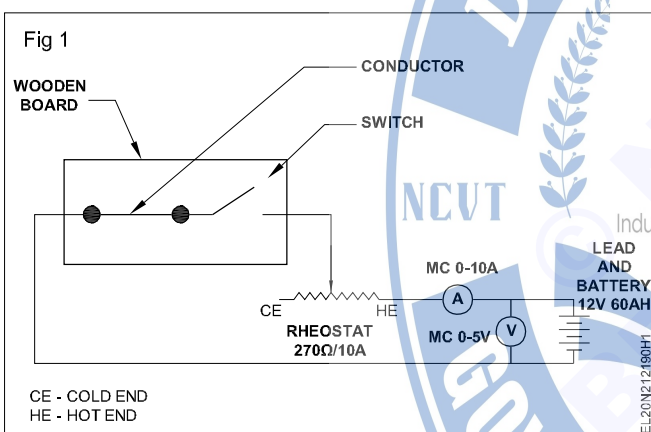

- 3 Connect rheostat, ammeter voltmeter and battery. (Fig 1)
- 4 Keep rheostat at cold end (maximum resistance position) and switch 'ON' and note the ammeter and voltmeter readings and enter in the Table 1.
- 5 Move the rheostat at middle position and note down the ammeter and voltmeter readings and enter in Table 1.

**At this stage the conductor may get heated up (or) it will show the system of heating.**

- 6 Adjust further more the rheostat position to hot end (reduce the resistance) slowly keeping a watch on conductor it may brake now.

- 7 Observe if the conductor is not broken and increase further position of rheostat towards hot end till the conductor breaks and note down the corresponding meter readings in Table 1.

- 8 Note down this is the maximum current carry capacity of the conductor.

**If the conductor is not broken, reduce the thickness of conductor (or) change the battery.**

- 9 Connect the aluminium and alloy conductor separately and repeat the steps to find the maximum current capacity of the 2 to 9 conductors.
- 10 Tabulate all the readings and show to your instructor.

- 11 a Maximum current capacity of copper conductor is \_\_\_\_\_ Amp
- b Maximum current capacity of aluminium conductor is \_\_\_\_\_ Amp
- c Maximum current capacity of alloy conductor is \_\_\_\_\_ Amp

Table 1

Sl.No.	Rheostat Position			Conductor	Voltage	Current	Remarks
	Cold end	Mid end	Hot end				
1		X	X	Copper			
2	X		X				
3	X	X					
4		X	X	Aluminium			
5	X		X				
6	X	X					
7		X	X	Alloy			
8	X		X				
9	X	X					

'X' denotes the inactive positions of the rheostat and blank space denotes active positions in the above Table 1.



Skill India  
कौशल भारत - कुशल भारत

NCVT



Industrial Training Institute

NCVT

GOVERNMENT OF INDIA

**Fasten, jumper in pin, shackle and suspension type insulators**

- Objectives:** At the end of this exercise you shall be able to
- select the pin type, shackle type and suspension type insulators
  - fasten jumper in cross-arm of pole with pin insulator
  - fasten the jumper in shackle type insulator
  - fasten the jumper in suspension type insulator.

Requirements	
<p><b>Tools/Equipment /Material</b></p> <ul style="list-style-type: none"> <li>• Insulated combination plier 200mm - 1 No.</li> <li>• DE spanner set 6 to 25mm - 1 Set</li> <li>• Adjustable spanner 25mm - 1 No.</li> <li>• Wooden or nylon mallet 1/2kg - 1 No.</li> <li>• Ladder 6m long - 1 No.</li> <li>• Wire stripper 150mm - 1 No.</li> </ul>	<p><b>Material</b></p> <ul style="list-style-type: none"> <li>• Suspension type insulator - 2 Nos.</li> <li>• Shackle type insulator - 2 Nos.</li> <li>• Pin type insulator - 2 Nos.</li> <li>• Flat aluminium tape - as reqd.</li> <li>• Binding wire 14 SWG aluminium - 5m</li> <li>• ACSR conductor - as reqd.</li> <li>• Safety belt - 1 No.</li> <li>• Clamp - as reqd.</li> <li>• Nut and bolt - as reqd.</li> </ul>

**PROCEDURE**

**TASK 1 : Fasten the jumper in pin insulator**

- 1 Keep the ladder on the pole and ask the helper to hold the ladder. climb up the ladder with the guide rope and spanner set.
- 2 Fix the pin type insulator to the cross-arm of the existing pole.
- 3 Tape the neck of the pin insulator with flat aluminium tape.
- 4 Lift the Aluminium Contactor Steel Reinforced (ACSR) conductor and keep it in between pole and the pin insulator.
- 5 Lay the ACSR wire on the slot of the pin insulator and ask the other helper to stretch the conductor with a wire stripper.
- 6 Take the binding wire of about 2 metres length, leaving equal length on both sides. Bind two turns on the insulation (Fig 1a) around the neck of the pin insulator.

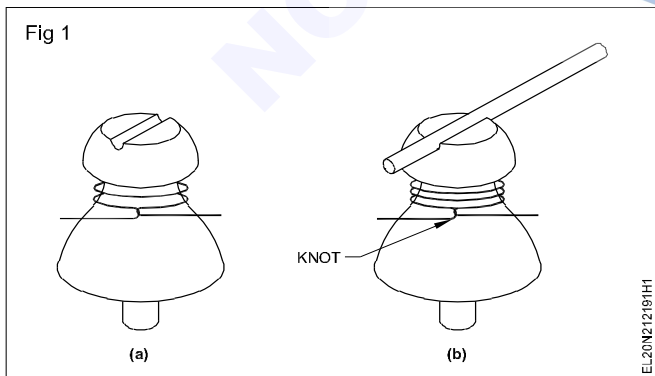

- 7 Make a knot of the binding wire with the free ends tightly. (Fig 1b)



Skill India  
कौशल भारत - सुरल भारत

- 8 Bind the free ends of the binding conductor over the line conductor tightly in the opposite direction. (Fig 2)

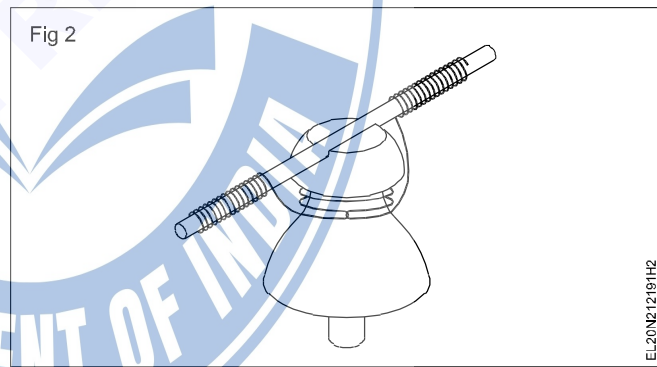

**Binding should be tighten without any gap.  
Where deviation or bend comes the ACSR conductor bind on the neck of the pin insulator. (Fig 3)**

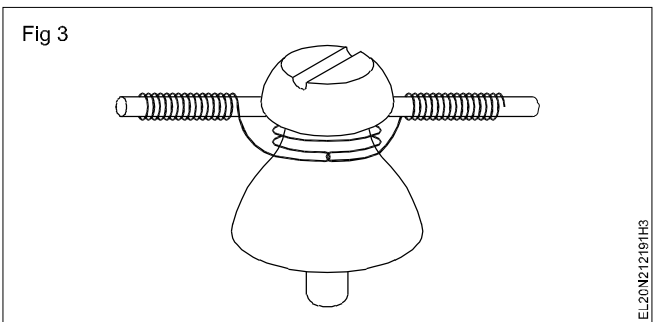

9 Complete the binding by giving about 15 turns on both sides.

10 Cut the extra binding wire and round off the raised ends.

### TASK 2 : Fasten jumper in shackle insulator

- 1 Keep the ladder on the pole and ask the helper to hold the ladder. Climb up the ladder with the guide rope and spanner set.
- 2 Fix the shackle insulator to the cross-arm with 'C' clamp.
- 3 Tape the ACSR conductor with flat aluminium tape where it touches the insulator.
- 4 Ask the helper to properly tie the O.H. conductor to the rope and lift the conductor to the cross-arm position.

**While tying the conductor to the rope the helper should leave atleast 1 metre length of conductor free at the end for binding.**

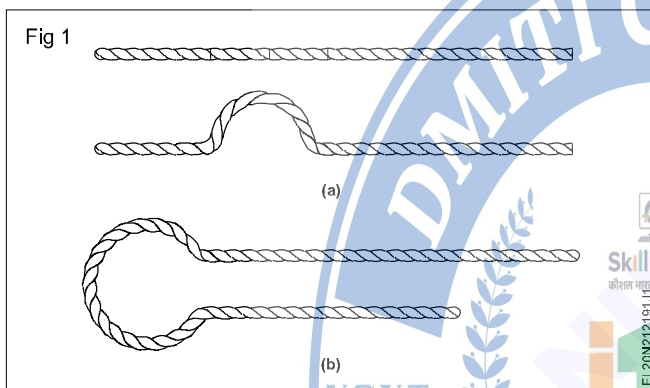

- 5 Insert the conductor around the groove of the insulator leaving half metre at the end. (Fig 1a & 1b)
- 6 Bind the ACSR conductor with 14 SWG aluminium binding wire tightly (Fig 2a) about 100 to 150 mm approximately.
- 7 Bend the end of the ACSR conductor in Fig 2(b). and complete the binding work .

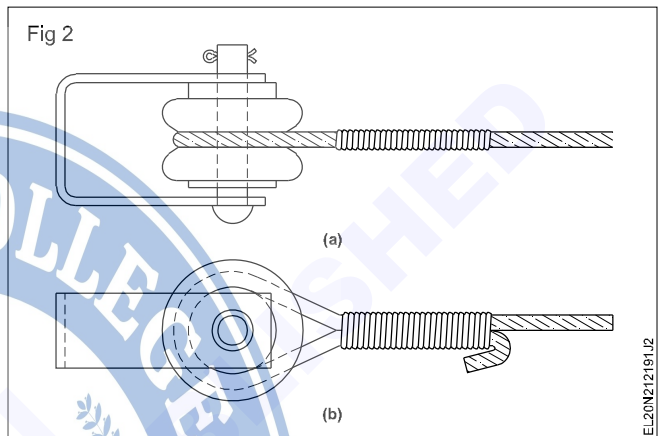

**Ground clearance of overhead conductor should not be less than 4.572 M for low and medium voltage.**

### TASK 3 : Fasten Jumper in suspension type insulator

- 1 Keep the ladder on the pole and ask the helper to hold the ladder. Climb up the ladder with the guide rope and spanner set.
- 2 Fix the suspension insulator to the cross-arm.
- 3 Ask the helper to properly lift the conductor to the cross-arm position.
- 4 Place the conductor in between two clamps.
- 5 Tight the bolt & nut of the clamp perfectly.
- 6 Bind the ACSR conductor with 14 SWG aluminium wire tightly Fig 1 in the suspension insulator.

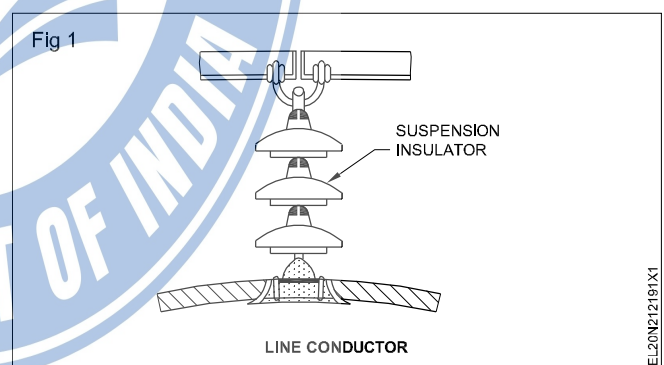

7 Complete the work and report to your instructor.

**Erect an overhead service line pole for single phase 240V distribution system in open space**

**Objectives:** At the end of this exercise you shall be able to

- select the place to erect the pole
- select the type of pole to be erected
- fix the cross-arm on the pole
- dig the pit and erect the pole.

**Requirements**

**Tools/Instruments**

- D.E. spanner set 6mm to 32mm - 1 Set.
- Combination pliers 200mm - 1 No.
- Heavy duty screwdriver 300mm - 1 No.
- Safety belt to work on pole - 1 No.
- Crowbar 2m long 40mm dia - 1 No.
- Spade - 1 No.
- Shovel - 1 No.
- Plumb bob with thread - 1 No.
- Cotton or jute rope 15m long - 1 No.
- Hammer ballpein 500g - 1 No.
- Safety belt - 1 No.
- Bamboo ladder - 1 No.
- Draw pulley - 1 No.
- Aligning rod - 1 No.
- Metal ram - 1 No.

- M.S. angle iron cross-arm 50mm x 50mm x 6mm size suitable for 240V supply line - 1 No.
- 'C' clamp M.S. size as required with nuts, bolts and washers - 2 Sets.
- Country wood plank 2m long, 30cm width 5cm thick - 1 No.
- Cement, sand, blue metal chips etc as per the size of pit - as reqd.
- Stay insulator (egg insulator) - 2 Nos.
- Double screw stay tightener - 2 Nos.
- C.I. stay plate - 2 Nos.
- Stay rod - 2 Nos.
- H.D.G. steel wire (stay wire) 7/16 SWG - 16m
- 50 x 12mm size M.S. bolts and nuts with washers - 2 Nos.
- Base plate for pole - 1 No.
- Casuarina pole of suitable height - 4 Nos.
- Wooden box of suitable size having 2 side openings for concrete pedestal - 1 No.

**Materials**

- Wooden/RCC/iron/tubular pole of 6m length - 1 No.

**PROCEDURE**

- 1 Select the place for fixing the pole near the building based on the span.
- 2 Select the type of pole to be erected. (Fig 1)
- 3 Dig a pit about 1/6th height of the pole having a diameter of minimum 3 times that of the dia of the pole bottom.
- 4 Prepare a mixture of concrete having a ratio 1:2:4 (one part cement, two part coarse sand and four part 2 cm blue metal chips) and pour the same in the bottom of the pit to a height of 15cms.
- 5 Ram the concrete and allow it to settle for a minimum period of 48 hours.
- 6 Keep the base plate for the pole at the bottom of the pit.
- 7 Fix a vertical straight pole on the plumb line in the pit. Refer (Fig 2)
- 8 Bring the pole and place it near the pit so that the bottom of the pole is at the edge of the pit.
- 9 Insert the wooden plank (board) vertically at one side of the pit facing opposite to the bottom portion of the pole.

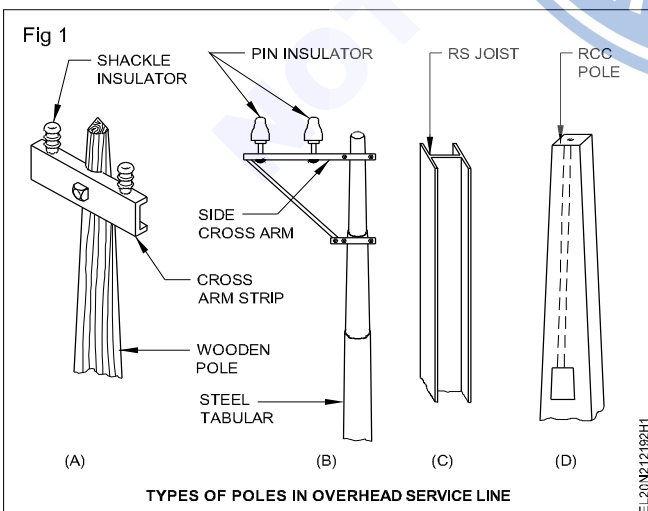

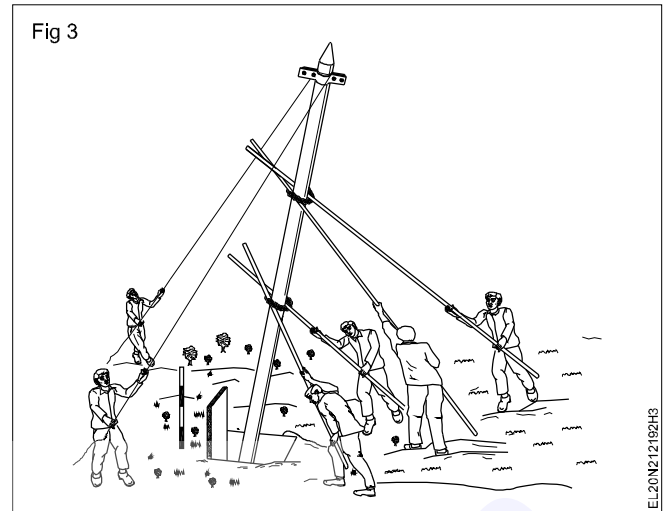
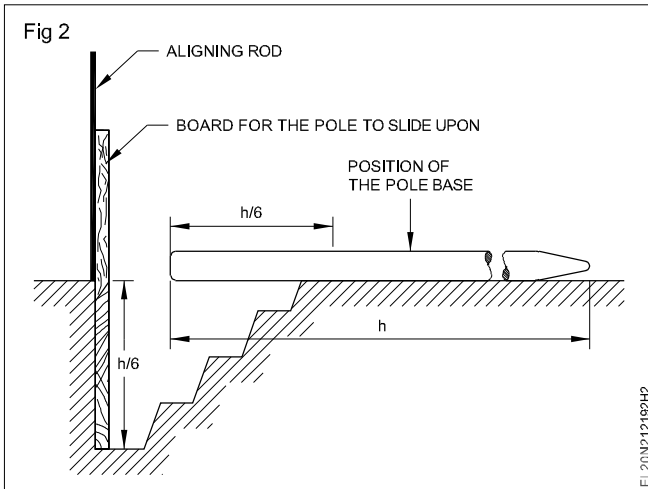

10 Fix the cross arms at the top of the pole below 30 cm from the top, with the help of 'C' clamps rigidly.

11 Tie the two ropes just below the cross arms.

**Ensure that the cross arm is in the required direction**

12 Place the casuarina pole at a distance of  $\frac{1}{3}$  height of the top and also  $\frac{1}{3}$  height from the bottom of the pole.

13 Prepare concrete mixture in the ratio of 1:3:4 (cement, sand and 1 cm blue metal chips).

14 Lift the pole step by step with the help of a rope and casuarina pole (Fig 3) and place it on the pit exactly vertical.

15 Check the vertical position with the help of an aligning a rod and plumb bob.

16 Pour the concrete mixture around the pole inside the pit and then place the wooden box around the pole.

17 Pour the concrete mixture in the box to a height of 0.5m above the ground level. Ram the mixture properly.

18 Cure the cement concrete for about 48 hours.

19 Remove the wooden box and plaster the cement concrete above the ground surface to have a smooth finish.

20 Fix the stay rod to the ground at a distance so as to get  $45^\circ$  to  $60^\circ$  between ground level and stay wire should be placed in the opposite direction to the line.

21 Cut the stay wire into 2 pieces of equal length.

22 Fix one end of each piece of the stay wire to the strain insulator (egg insulator).

23 Fix the other end of the second piece of stay wire to the stay. Tighten using a thimble.

24 Fix the stay and tighten to the stay.

**Assuming the stay rod is fitted to the ground through a concrete structure which was sufficiently cured.**

25 Tighten the stay tightener nut till there is no sag in the stay.

**After drawing the overhead lines the stay should be tightened to compensate the tension of the overhead lines and to keep the pole in the vertical position.**

**Practice on laying of domestic service line**

**Objectives:** At the end of this exercise you shall be able to

- locate the nearest pole, specify and estimate the quantity of materials required
- prepare the GI pipe, bend in the form of a goose neck and install it in position
- prepare the support GI wire with (ring insulator as) separators and service cable
- draw the service cable and connect it to the energy meter
- connect the service cable to the overhead lines through an aerial fuse
- earth the service cable support wire at both ends.

**Requirements**

**Tools/Instruments**

- Electrician tool kit - 1 No.
- Pipe jumper 25 mm dia. 40 cm length - 1 No.
- Pipe wrench 50 mm - 1 No.
- Megger 500V - 1 No.
- Rawl plug tool No.10 with bit - 1 No.
- Hacksaw adjustable with blade 300 mm - 1 No.
- Safety belt - 1 No.
- Bamboo ladder 6 m. height - 1 No.
- GI die set with stock 15 to 40 mm - 1 set

- GI wire 7/3.15 mm size - 5 m
- Porcelain ring insulator - 70 Nos.
- GI pipe 40 mm - 3 m.
- GI bends 40 mm - 1 No.
- MS clamps 40 mm, 3mm thick - 4 Nos.
- Wood screws 40 mm No.8 - 8 Nos.
- Silver paint 200 ml. - 1 No.
- Stay insulator - 2 Nos.
- Bombay nails - 8 Nos.
- Cable glands (heads) - as reqd.
- Bricks - as reqd.
- Sand - as reqd.
- Cable compound - as reqd.
- Solder - as reqd.
- Clamps for fixing cable - as reqd.

**Materials**

- Earth clips 40 mm - 6 Nos.
- Twin core service cable weather-proof or PVC sheathed insulated cable 2.5 sqmm., 250V grade - 20 m
- GI wire 10 SWG - 30 m
- GI wire 12 SWG and 22 SWG - 15m each

**PROCEDURE**

**Drawing a service line is the work of the staff of the electricity board. Some of the trainees may get employment in state electricity board. When working on a service line it is utmost necessary to make a shut down before connecting the service cable to the service line.**

- 1 Locate the nearest electrical pole and measure the distance from the pole to the building to which the service line is to be drawn (Fig 1).

**Care should be taken to see that the service cable does not cross the adjacent building area. In some cases an intermediate pipe structure may be needed to avoid crossing.**

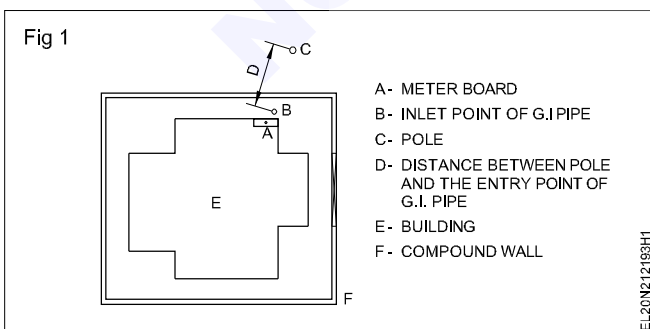

- 2 Identify whether the supply required for the house is single or 3-phase.
- 3 Locate the position of the meter board and determine the height of GI pipe to be fixed for service connection. Refer to Fig 2, record the findings in the Table 1.

**Preferably the entry height of the service cable of the GI Pipe should be at the height of the pole. If this is not possible due to the lower height of the house, arrange to fix the GI pipe at a maximum possible height.**

- 4 Determine the length required for the goose neck bend and the thickness of the wall. Refer to Fig 2 and enter these particular in Table 1.

Normally a goose neck bend should have a diameter 12 times the diameter of the pipe. Say for a 25mm pipe the goose neck diameter will be  $25 \times 12 = 300$  mm.

Table 1  
Service connection measurements in metres for the supply of single/three phase

Distance between the pole and the entry point of the GI pipe D	Height of the GI pipe neck H	Length of the goose bend P	Wall thickness in mm T	Height of the meter board L	Total length
					<p><b>Length of the GI pipe</b>  <math>H+P+T</math> - (Length of bend)metres.</p> <p><b>Length of the GI wire as service line support wire.</b>  <math>D+P+3</math> metres.</p> <p><b>Length of service cable</b>            Single phase = <math>[(D+H+P+T+L) 2] + 10\%</math>            3-phase = <math>[(D+H+P+T+L) 4] + 10\%</math></p>

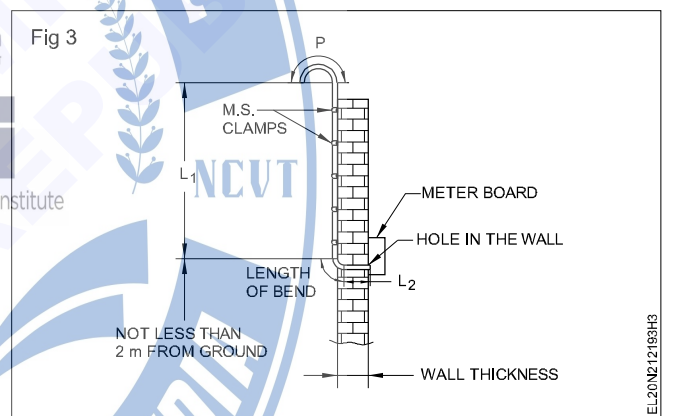
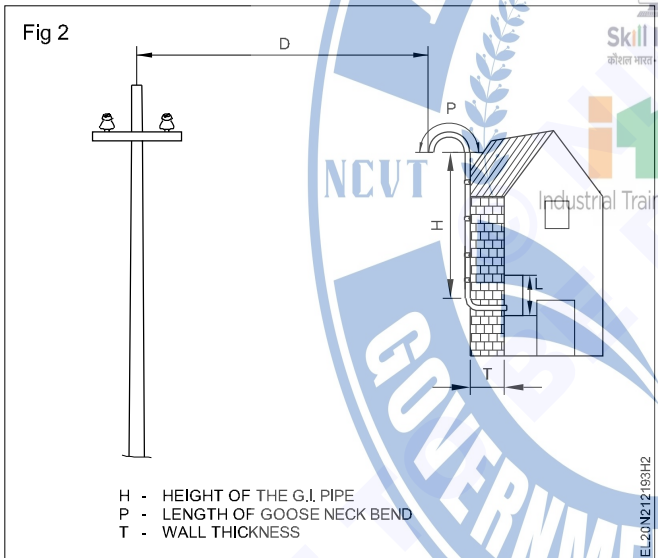

The hole should not be less than two metres from the ground.

- 5 Determine the length of the cable required from the inside wall to the meter terminals and enter the recorded measurements in Table 1. Calculate the required length of service cable and GI pipe from the above particulars and enter the values in Table 1.
- 6 Mark and cut two pieces of GI pipe of length  $L_1$  and  $L_2$ . Refer to Fig 3.
- 7 Thread the GI pipe of length  $L_1$  and  $L_2$  at one end.
- 8 Bend one end of the longer GI pipe  $L_1$  to form the goose neck having a diameter equal to 12 times of the pipe diameter.
- 9 Make a hole in the wall with a pipe jumper such that the pipe when fitted is nearer to the energy meter terminals.

- 10 Fix the GI bend to the GI pipe. (Fig 3)
- 11 Pass the fish wire (GI wire of 20 SWG) through the assembled pipe.
- 12 Fix the GI pipe vertically to the wall using MS clamps. (Fig 3)

Use minimum one stay bow to the GI pipe in case the GI pipe has to be erected above the wall. Refer to (Fig 4a) and fix the other end of the stay bow to the eye bolt fixed to the roof.

- 13 Bind two numbers of the small ring insulators (separators) in the case of single phase supply, in one set by means of suitable GI wire of 20 SWG. (Fig 4b)

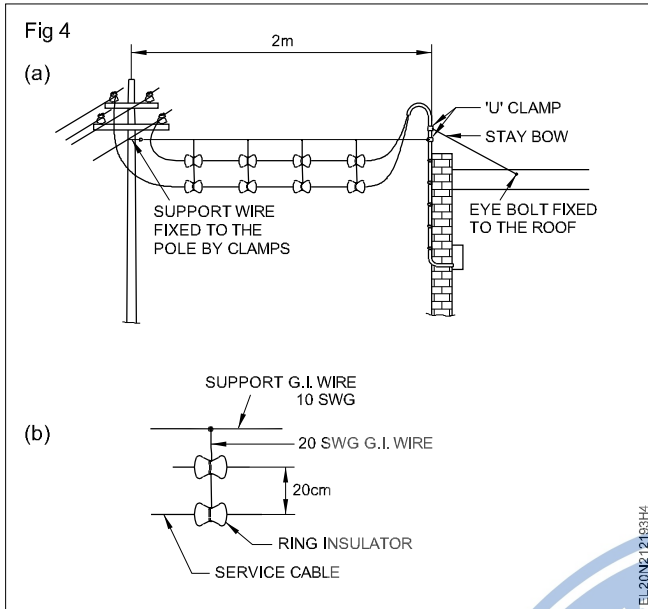

**Keep 20 cm gap between the ring insulators for 250 volt and 30cm for 440 volt.**

14 Bind such sets at a uniform distance to a main support G.I. wire of 10 SWG.

15 Pass the service wire (cable) through the ring insulators leaving sufficient length of wire for connection at both ends.

**Mark the cables as phase and neutral at both ends.**

16 Fix one end of the support GI wire to the vertical pipe below the goose neck using 'U' clamps. (Fig 4a)

**The 'U' clamp fixture should be sufficiently strong to withstand pull exerted by the weight of the service line and wind force.**

17 Fix the other end of the support GI wire to the pole. (Fig 4a)

**Use a ladder and wear a safety belt. Before climbing up the pole permission should be obtained from the electricity board and a shut down taken for safety.**

18 Draw the service cables through the GI pipe by fish wire providing bushes at both ends of the pipe.

19 Connect the service lines to the energy meter and then to the cut outs.

20 Connect an earth continuity conductor (GI 12 SWG) between the 'U' clamp of the GI pipe and to the consumer main board earth terminal.

21 Provide earth clamps on the GI pipe for earthing.

22 Connect the phase cable of the service cable to the phase wire of the distribution line through a joint or by a connector.

**In some electricity boards aerial fuses are introduced between the distribution line and the service cable. Follow the procedure as per the local regulation.**

23 Connect the neutral cable of the service cable to the neutral wire of the distribution line through a joint or by a connector.

**Service lines should be inspected by competent authority (EB) and the aerial fuse will be provided by them only.**

24 Inspect the service line connections and then energise the line.

**Install bus-bar and bus coupler on LT line**

**Objectives:** At the end of this exercise you shall be able to

- determine the location for installing bus bar and select the bus bar with bus coupler
- mount and fix the bus bar
- insert the plug -in-boxes in the bus bar system and also bus coupler
- test for earth continuity of bus bar and for insulation resistance.

Requirements	
<p><b>Tools/Instruments</b></p> <ul style="list-style-type: none"> <li>• Electrician tool kit - 1 No.</li> <li>• DE spanner set (6 mm to 25 mm ) - 1 Set</li> <li>• Crimping tool - 1 Set</li> <li>• Ladder with adjustable height - 1 No.</li> <li>• High stool - 1 No.</li> <li>• Hand hacksaw frame 300 mm - 1 No.</li> <li>• Megger 500V - 1 No.</li> </ul>	<p><b>Materials</b></p> <ul style="list-style-type: none"> <li>• Busbar of available current rating and standard length / current rating - 2 Nos.</li> <li>• Plug - in boxes 32A - 2 Nos.</li> <li>• Busbar brackets, M.S flat, for suspending the bus bar or GI pipe for supports and all supporting accessories - as reqd.</li> <li>• Nut and bolts size and quantity for busbar extension standard accessories - as reqd.</li> <li>• Bus coupler - 1 No.</li> </ul>

**PROCEDURE**

- 1 Trace the workshop layout and calculate the total electrical capacity of machines, main power supply entry point and determine the rating.
- 2 Determine the busbar layout and the required length of the busbar.
- 3 Determine from the site what type of support is required to lay the busbar.
- 4 Mount and fix the busbars to the supporting structure. (Fig 1 and Fig 2).
- 5 Insert the plug - in-boxes in to the plug -in-points. (Fig 1)

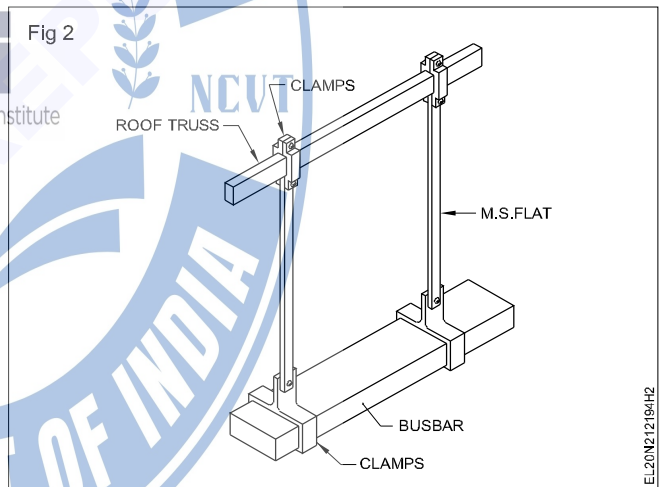

- 6 Couple the new busbar mechanically and electrically by using bus coupler, if another length is needed. (Fig 3)

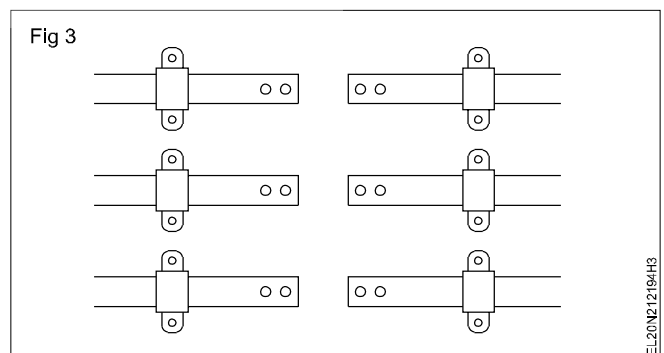
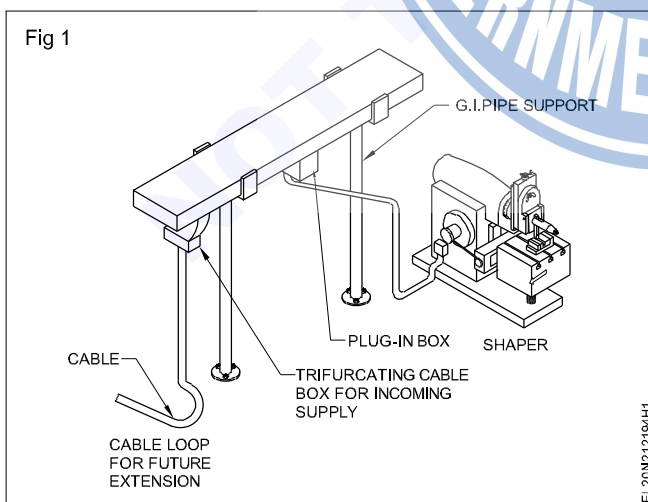

**If any over lapping ends of the busbar join by bolting together.**

7 Secure busbar with screws locking plates.

**A connector - assembly which is commercially available comprises of**

- rubber locating ring,
- busbar insulating tube

**If connector insulating tube is knocked out condition. While coupling, make sure that the connector - assembly is properly secured.**

8 Terminate the plug in boxes to the loads through metal conduit runs and suitable cables.

9 Test the bus bar system for earth continuity.

10 Test the system for continuity and insulations.

