

Simple repair work - simple assembly of machine parts from blue prints

Objectives: At the end of this exercise you shall be able to

- identify the defects in tail stock assembly
- dismantle the tail stock assembly
- identify the defective/worn out parts
- prepare the defective parts
- assemble in the tail stock
- check the tail stock performance.

TASK-1

DISMANTLE THE TAIL STOCK AND KEEP THE PARTS IN A SEPARATELY AND IDENTIFY THE DAMAGED WORNOUT PARTS

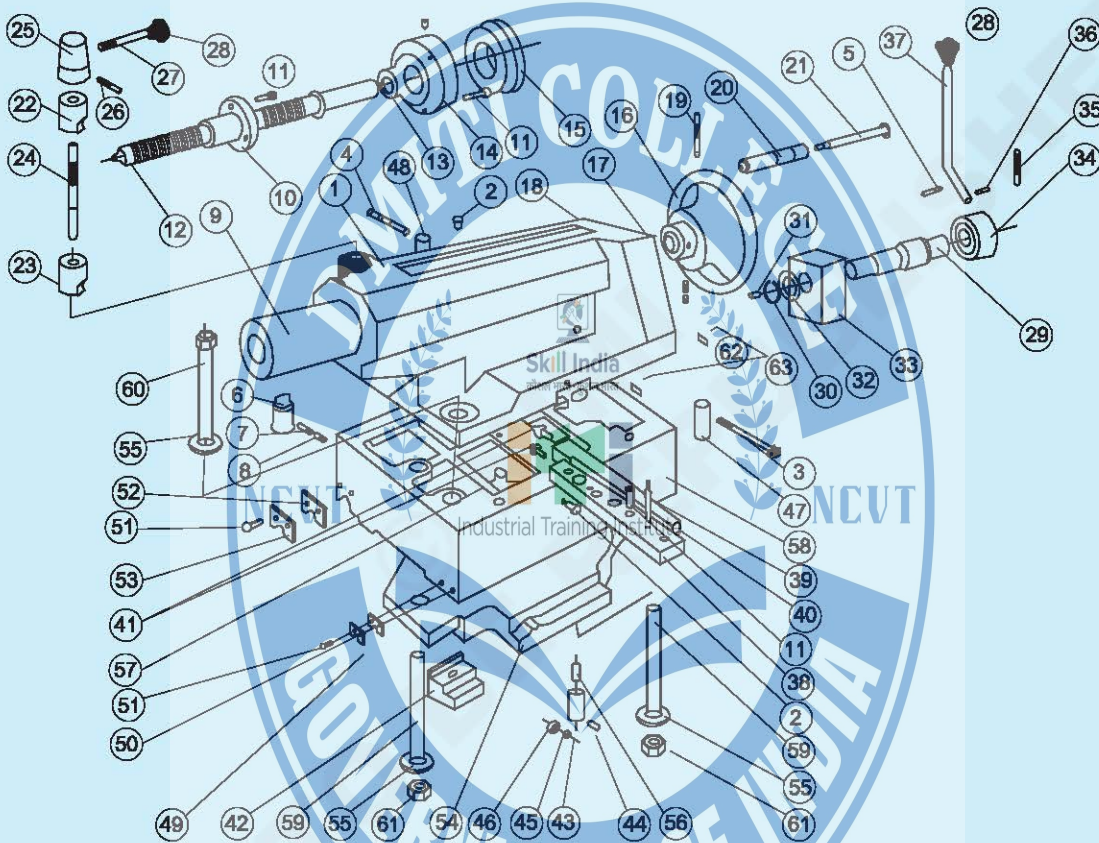

TASK-2

PREPARE A NEW SCREW ROD INSTEAD OF WORNOUT SCREW ROD

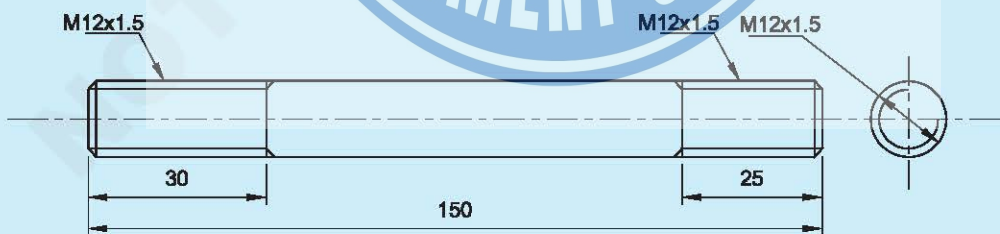

1	Ø14-155	SCREW ROD	Fe310	TAIL STOCK REPAIR WORK	24	1.8.108
NO.OFF	STOCK SIZE	SEMI-PRODUCT	MATERIAL	PROJECT NO.	PART NO.	EX. NO.
<p>SCALE NTS</p> <p>SIMPLE REPAIR WORK:SIMPLE ASSEMBLY OF MACHINE PARTS FROM BLUE PRINTS</p>					DEVIATIONS ±0.04 mm	TIME
					CODE NO. FI20N18108E1	

Job Sequence

Identification of defects in a tail stock

- Identify defect in a tail stock.
- Rotate the tail stock hand wheel for moving the spindle.
- Lock the spindle using the locking lever.
- Rotate the tail stock hand wheel and check the spindle movements and locking position. If the spindle is not locked properly it will move.
- Hence, it is known as screw rod spindle lock is not working properly.
- Dismantle the spindle locking unit from the tail stock.
- Prepare the new screw rod instead of defective screw rod.
- Assemble the prepared screw rod instead of wornout screw rod.
- Check the tail stock performance and lock the spindle in the proper position.

**Tailstock
Group Assembly Drawing**

No.On DRG	Qty/Group	Description	Size
1	1	Tailstock	
2	6	Oil nipple	C8
3	1	Hex. Soc. hd. cap. screw	M8 x 100
4	1	Hex. Soc. hd. cap. screw	M8 x 60
5	1	Cyl. pin	10 x 50
6	1	Key	
7	1	Grub Scr. 'G'	M8 x 16
8	1	Grub Scr. 'A'	M8 x 10
9	1	Sleeve	
	1	Sleeve (with tenon slot)	
10	1	Nut	
11	10	Ind Hex. Soc. hd. cap. screw	M8 x 25
12	1	Screw	
13	1	Th. ball bearing (51205)	25/47 x 15
14	1	Flange	
15	1	Graduated collar	
16	1	Handwheel	
17	3	Compression spring	
18	3	Steel Ball Class V	5/16" class V
19	1	Taper pin	6 x 60
20	1	Handle	
21	1	Handle rod	
22	1	Clamp piece	
23	1	Clamp piece	
24	1	Screw rod	
25	1	Cap	
26	1	Taper pin	6 x 50
27	1	Handle rod	
28	2	Knob	
29	1	Eccentric shaft	
30	1	External circlip	A 30
31	1	Cyl. plug	6
32	1	Spacer	
33	1	Clamp nut	

No.On DRG	Qty/Group	Description	Size
34	1	Cap	
35	1	Taper pin	6 x 80
36	1	Taper pin	4 x 30
37	1	Handlerod	
38	1	Tenon	
39	2	Int. Thrd. taper pin	8 x 50
40	1	Gib	
41	2	Spec. screw	
42	1	Clamp piece	
43	3	Bearing holder	
	3	Hex. soc. grub screw	M6 x 10
44	3	Spec. pin	
45	3	Needle roller bearing DL-810	8/14 x 10
46	3	Bearing bush	
47	1	Shaft	
48	1	Shaft	
49	2	Wiper	
50	2	Plate	
51	8	Slotted ch. hd. scr. 'A'	M6 x 18
52	2	Wiper	
53	2	Plate	
54	1	Clamp plate	
55	3	Spec. washer	
56	3	Compression spring	
57	3	Spec grub screw	
58	1	Tailstock base (For NH22)	
	1	Tailstock base (For NH26)	
	1	Tailstock base (For NH32)	M20 x 130
59	2	Stud 'B' (For NH22)	
	2	Stud 'B' (For NH26)	M20 x 170
	2	Spec stud (For NH 32)	
60	1	Hex. bolt (For NH22)	M20 x 140
	1	Hex. bolt (For NH26)	M20 x 180
	1	Hex. bolt (For NH32)	M20 x 220
61	2	Self locking nut	0, 8d x M20

Rectify possible assembly faults during assembly

Objectives: At the end of this exercise you shall be able to

- dismantle the spindle and spindle pulley from drilling head
- clean and inspect the parts for worn out and damage
- assemble the spindle and spindle pulley
- test the spindle and spindle pulley for proper function
- rectify the hydraulic faults in power saw
- dismantle and assemble the wornout grinding wheel
- dismantle and assemble the gib from the cross slide of lathe.

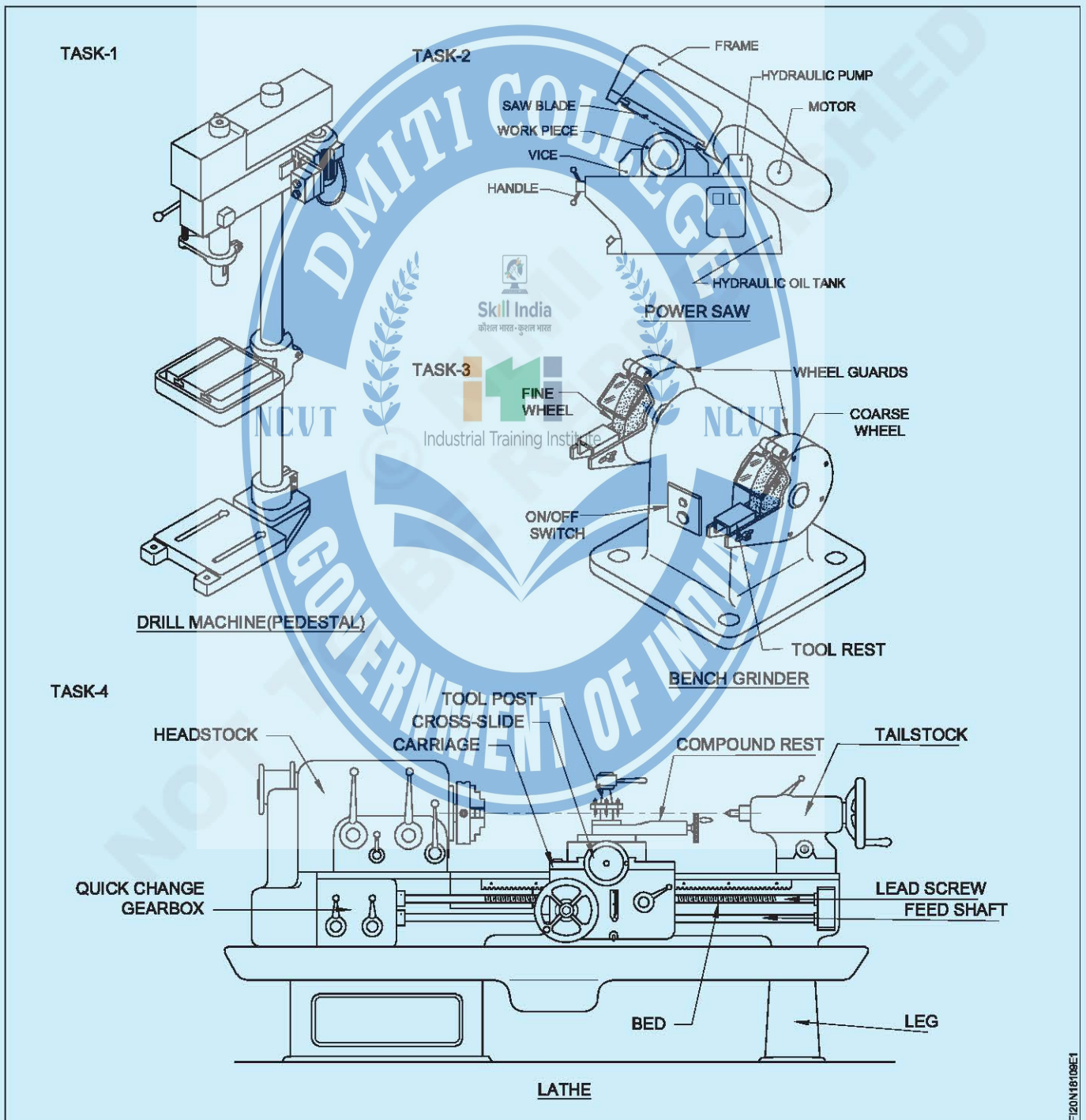

F120N18108E1

Job Sequence

TASK 1: Dismantle and assembly of spindle and pulley of drilling machine

- Remove the drill chuck and arbor (Part no 20 & 19) from the spindle
- Switch off the machine and remove the belt guard.
- Remove the 'V' belt (Part no 1) from the pulley.

Removal of spindle pulley and Hub assembly

- Loosen the nuts (Part no 2) from the spindle hub (Part no 4).
- Remove the stepped 'V' pulley (part no 3) from the spindle hub.
- Remove the feather key (part no 5).
- Remove the internal circlips (part no 6) from spacer (part no 8).
- Remove the external circlip (part no 9) from the end of spindle hub (part no 4).
- Remove the spindle hub and bearings (part no 7) from spacer.

Use aluminium or copper rod to avoid damage of hub and bearings.

Removal of spindle sleeve

- Remove the pinion with shaft from the machine.
- Straighten the toothed washer (part no 11).
- Loosen and remove the nut (part no 10) from spindle (part no 17).
- Remove the toothed washer from the spindle.
- Remove the bearings (part no 12) from the spindle sleeve (part no 14)
- Remove the O - Ring (part no 13).
- Remove the spindle sleeve (part no 14).
- Remove the spindle (part no 17) from the spindle sleeve.
- Remove the thrust bearing (part no 15) from spindle using hydraulic press.
- Clean all the dismantled parts and dry it.

Keep all the disassembled parts in a separate tray in proper order while dismantling.

Identification of worn out and damaged parts

- Check all dismantled parts of spindle and pulley, thoroughly and list out the damaged, worn out parts and fill up the table given.
- Replace the worn out and damaged parts and assemble the spindle and pulley.

- Assemble all the parts of the spindle and pulley in the reverse order and apply, grease, oil at necessary parts.

Care should be taken while fixing new bearings and the circlips.

- Fix the 'V' belt and adjust to proper tension.
- Mount the belt guard.

Test run the machine

- Switch on the power supply.
- Check the run out of the spindle by using lever type dial test indicator with magnetic stand.

Table

Sl.No.	Name of the parts	Remarks
1		
2		
3		

Parts of spindle and pulley

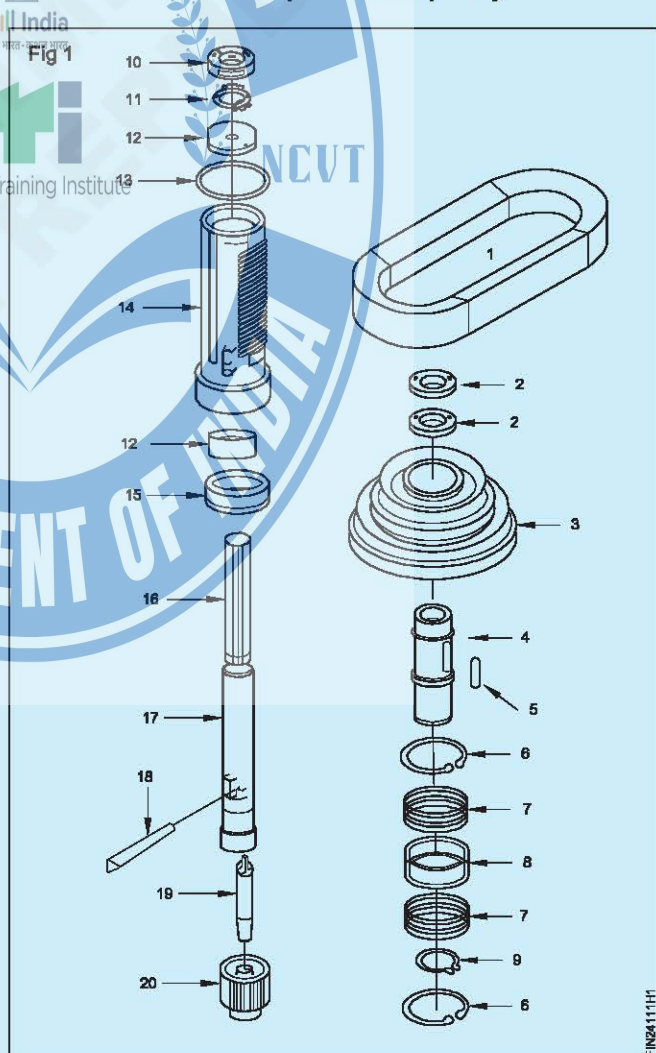

- Run the machine at slow, medium and high speed atleast 5 minutes.
- Listen if any abnormal noise hearing from spindle assembly.
- Check if any noise generating in the spindle assembly if so rectify the fault and run the machine without noise.

Parts

- | | |
|----------------------------------|-----------------------|
| 1 'V' Belt | 8 Spacer for bearing |
| 2 Nut | 9 External circlip |
| 3 Spindle pulley | 10 Nut |
| 4 Spindle hub (Internal splines) | 11 Washer |
| 5 Feather key | 12 Bearing |
| 6 Internal circlip | 13 O-Ring |
| 7 Bearing | 14 Spindle sleeve |
| | 15 Thrust bearing |
| | 16 Splines on spindle |
| | 17 Spindle |
| | 18 Wedge slot |
| | 19 Chuck arbor |
| | 20 Drill chuck |

TASK 2: Rectification of hydraulic fault in power saw

- Switch off the machine and remove the belt guards.
- Support the arm properly.
- Drain the hydraulic oil and keep it safely.
- Remove the connecting pin/circlip/split pin and loosen the fasteners in the hydraulic unit.
- Disconnect the oil lines and remove the hydraulic unit from the m/c.
- Dismantle the hydraulic unit and keep it in a separate tray Fig 2.
- Clean all the parts and dry it.
- Inspect oil flow part with compressed air.
- Inspect the oil seal/ 'o' rings/filter control valves/ valve seat.
- Replace / repair the worn out/damaged parts.

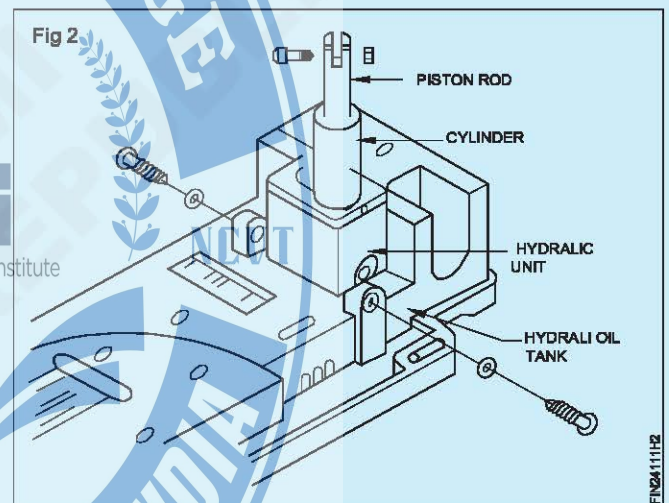

Assemble the hydraulic unit in the reverse manner of dismantling.

- Fix unit to the machine.
- Check the condition of drained oil if contaminated fill as per manufacturers recommended grade oil.
- Connect the oil lines & drive system and remove the arm support.
- Trail run the machine and observe the performance.
- Check any leakage in the oil line, if found arrest them.
- Adjust the control valve and verify to arm lifting & descending performance.
- Fix the belt guards.

TASK 3: Dismantling and assembling of a worn out grinding wheel

- Switch-off the electrical power supply.
- Dismount the safety glass bracket.
- Remove the grinding wheel covers.
- Unscrew the nuts from the spindle of the grinding wheel.
- Remove the tool rest.
- Remove the grinding wheels from the spindle.
- Remove the belts from the motor pulley.
- Disengage the grinding wheel head unit from the main body.
- Dismantle the wheel spindle from the wheel head.

- Extract the ball bearings from the housings/spindle.
- Clean the ball bearings and other parts.
- Inspect the bearings and other parts.
- Replace the bearings, if necessary.
- Change the belts, if damaged.
- Lubricate the bearings and other parts.
- Assemble the parts in the reverse sequential order.
- Replace the grinding wheels, if necessary.
- Check the smooth running of the bench grinder.

TASK 4: Dismantling and assembling of gib from the cross slide of a lathe

- Remove the adjusting screws from the dovetail slide.
- Dismantle the gib from the cross slide.
- Clean the slide surfaces.
- Check and inspect all the parts.
- Damaged parts of gib strip and adjustment screws should be replaced.
- Lubricate the slide ways.
- Assemble the gib and check the gib seating.
- If you find any defects, rectify it.
- Check adjusting screws thread.
- Lubricate the slide ways of gib strip.
- Assemble slide way, gib strip with saddle.
- Tighten the adjusting screws to give the correct freedom required in the assembly.
- Lock the movement of the adjusting screw by the check - nut.
- Check the slide ways smooth movement without any shake.
- If taper gib is provided in the assembly, properly position the gib by end screws.

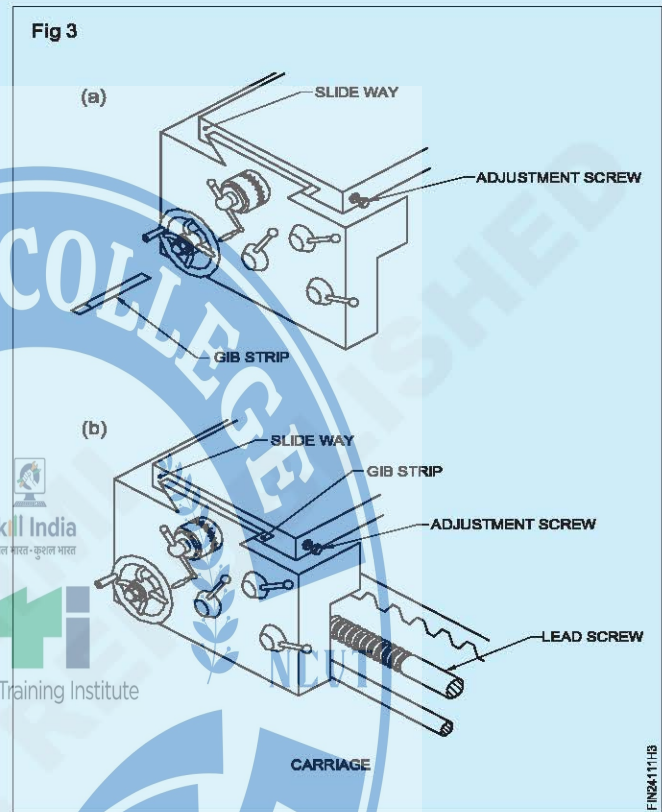

Skill Sequence

Fit a new grinding wheel -Task 3

Objective: This shall help you to

- fit a new grinding wheel in pedestal grinding machine.

Switch off the power supply to the machine

Clean the machine and remove any loose metal or abrasive particles.

Loosen the work rest clamp and remove the rest Fig 1.

Remove the outer plate of the wheel guard Fig 1.

The wheel clamping nut is now accessible.

Check the nut direction before loosening.

Loosen the nut using a spanner of the correct size Fig 2.

Remember that when facing the front of the machine, the spindle on the left has a left-hand thread. Turn the nut clockwise to loosen it.

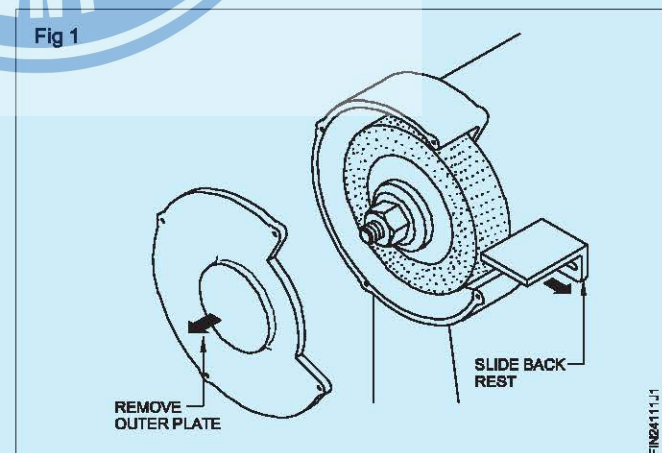

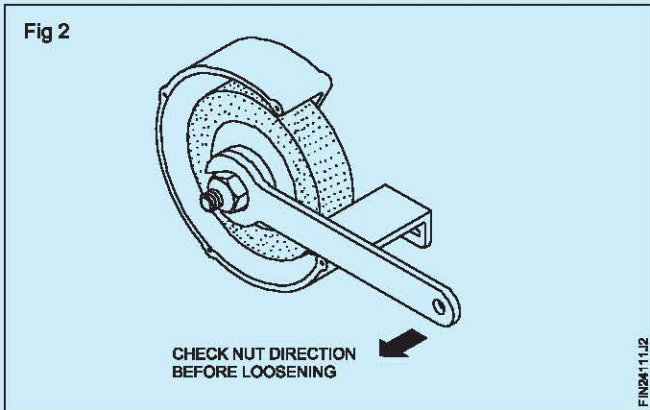

Remove the nut and the outer flange.

A light blow with a soft hammer may be needed to free it from the wheel.

Remove the worn out wheel from the spindle and place it in the scrap bin.

Check that the markings on the old wheel are the same as those on the new wheel Fig 3.

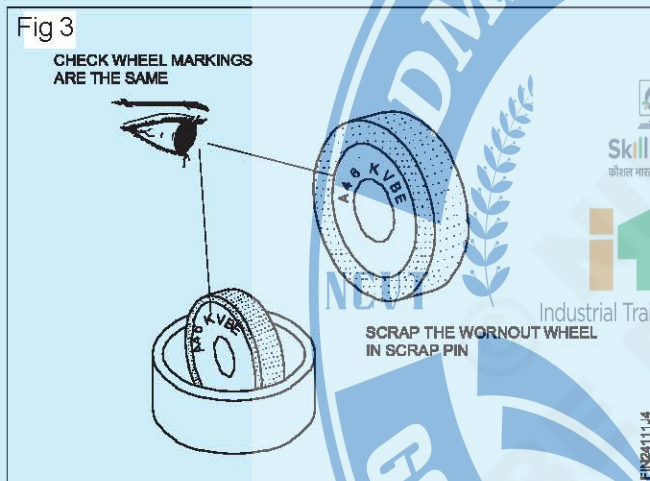

Remove any paper, washer that has adhered to the flange Fig 4.

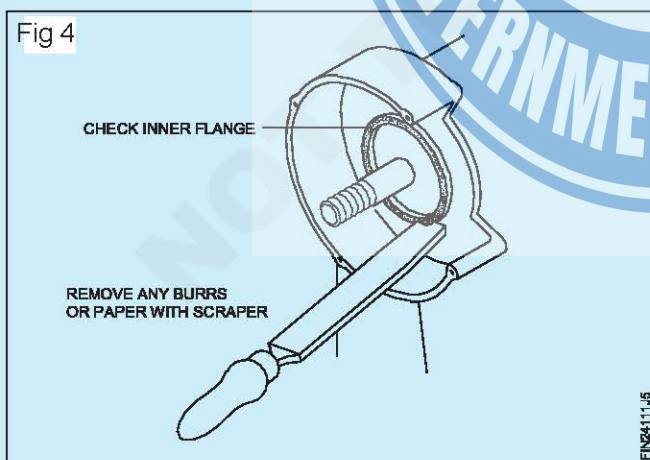

Clean the flange, spindle, thread and inside the guard.

Check that both the paper washers are intact in the new wheel.

Try the new wheel on the spindle Fig 5.

Scrape the lead bush to abstain a correct fit. The outer diameter of the new wheel should fit neatly inside the wheel guard, but with adequate clearance.

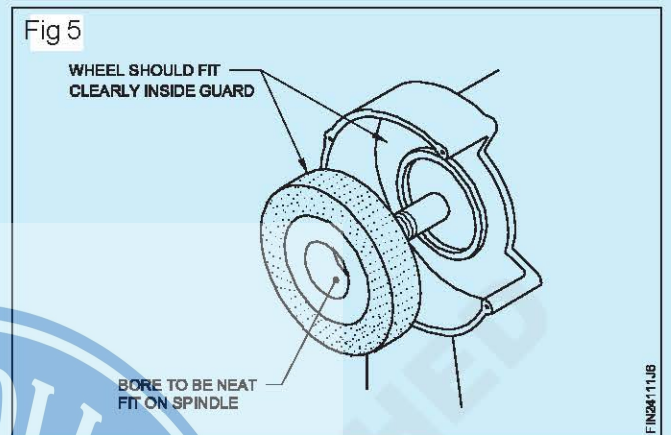

Push the wheel carefully against the driving flange and place the outer flange in position.

Screw up the clamping nut by hand, firmly enough to hold the wheel in position Fig 6.

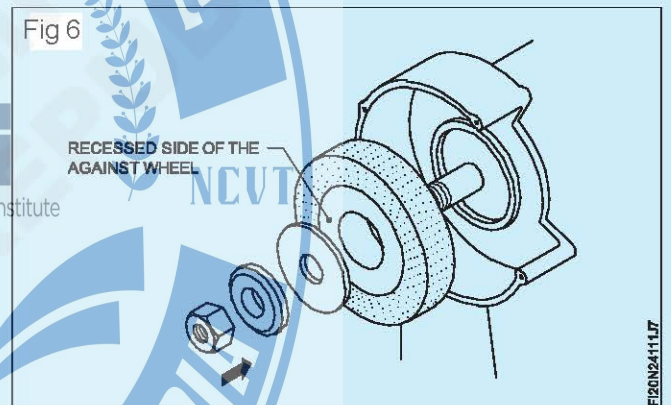

Turn the spindle and wheel a complete revolution.

Ensure that the wheel is running true, by rotating hand and it is clear of the inner part of the guard.

Tighten the nut sufficiently enough to ensure that the flanges will drive the wheel without slipping. (Fig 7 & 8)

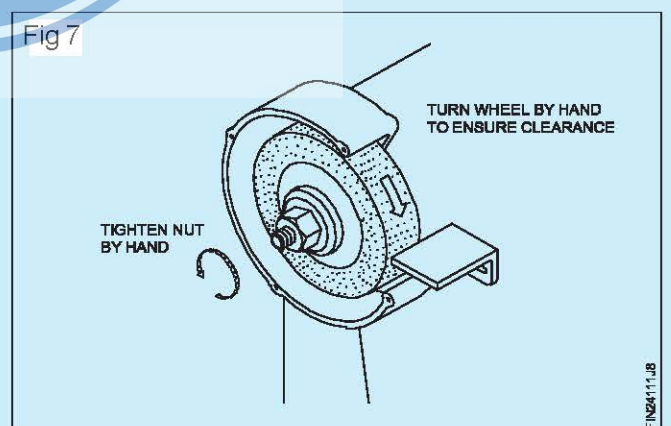

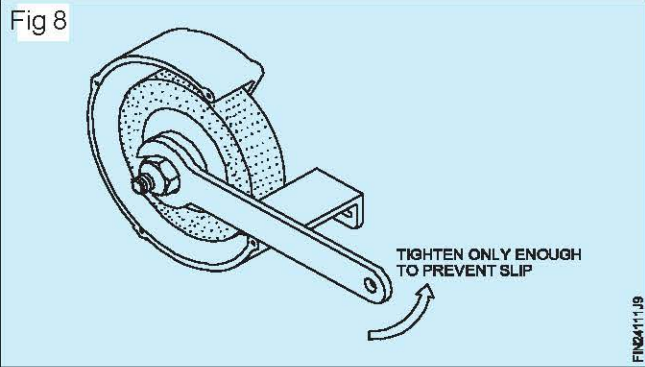

Refit the outer plate of the wheel guard Fig 9.

Reset the work rest as close to the wheel face as possible.

Tighten the work rest clamp firmly.

Rotate the wheel again by hand ensure that the wheel runs freely and true.

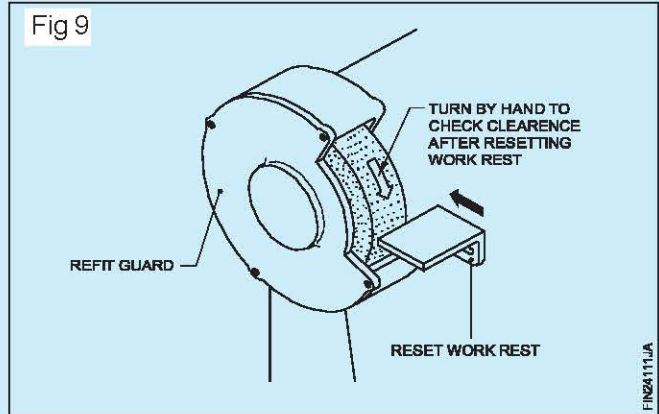

(Switch on the power supply and start the machine).

Allow the wheel to operate for one minute at full operating speed.

The machine is now ready for grinding operations.

Adjust the gib strip - Task 4

Objective: This shall help you to

- adjust and align the gib strip in a lathe.

Loosen the lock-nuts. (Fig 1)

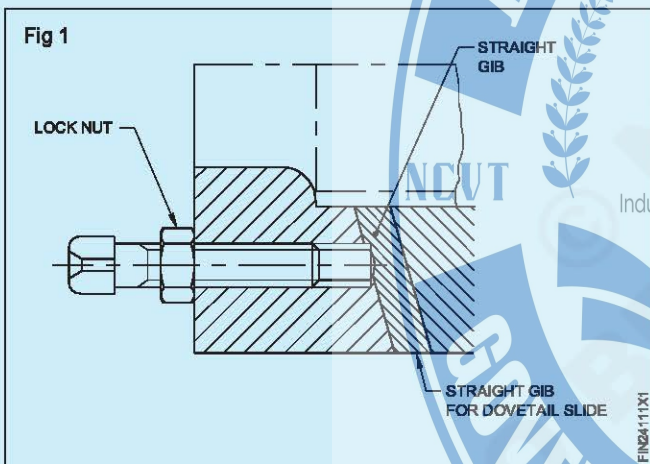

Remove the set screws. (Fig 2)

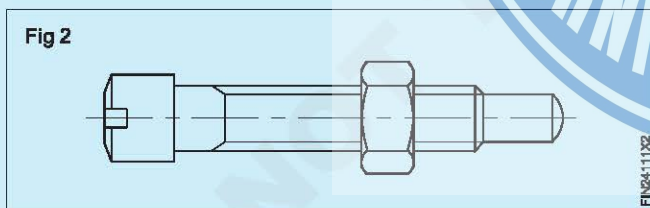

Pull the gib out. (Fig 3)

Clean all the parts.

Check the straightness of the gib using Prussian blue.

Scrape the gib to get even surface to prevent stick-slip motion of the cross-slide.

Lubricate all the parts.

Assemble the gib into the dovetail slide and position it. (Fig 4)

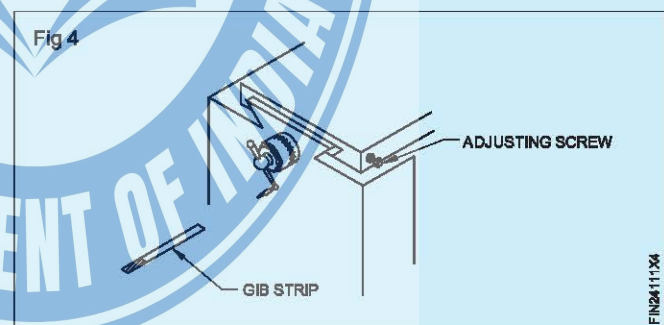
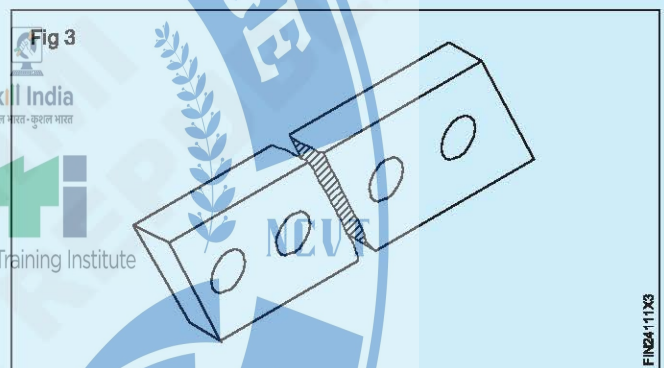

Adjust the screws and eliminate the clearance between the slides for getting the correct freedom required in the assembly.

Lock the movement of the adjusting screws by the check-nut.

Hold the gib in correct position firmly while locking with check-nuts.

Check the function of the cross-slide.

Perform the routine maintenance with check list

Objectives: At the end of this exercise you shall be able to

- perform the routine maintenance with check list
- rectify the defective items found.

Job sequence

1 Check the tension of the belt and adjust

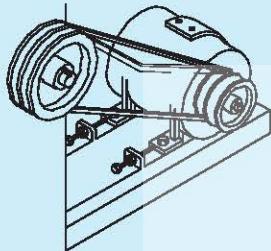

2 Check the movement of the carriage of the lathe

- Run the machine on different spindle speeds and check the speed.
- Engage the power feed and check the longitudinal and transverse feed movements.
- Check the function of clutches by operating the clutch lever.

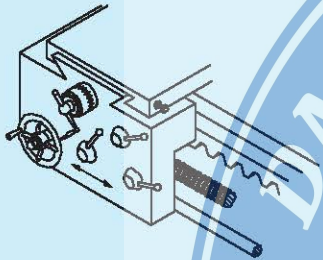

3 Check the movement of the cross-slide and the compound slide.

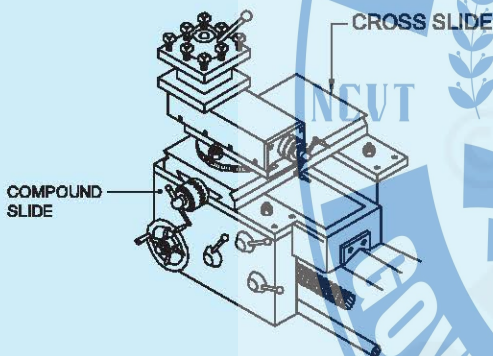

4 Check the oil level and the functioning of the lubricating pump.

- Check the coolant level and the functioning of the coolant pump.

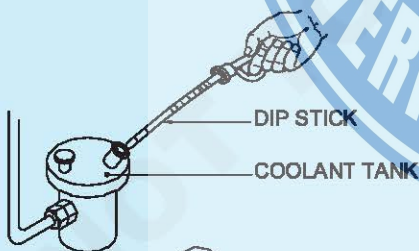

5 Check the safety guards and ensure that they are in position.

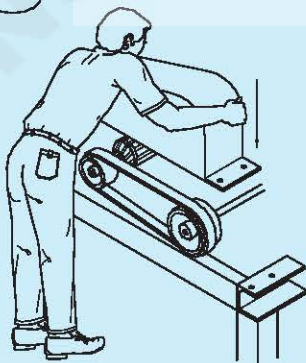

Inspect the following check list items of centre lathe
and tick it in appropriate column.

Table

Items to be checked	Good working/Satisfactory	Defective	Remedial measures to be carried out
Belt and its tension			
Bearing sound			
Driving clutch and brake			
Exposed gears			
Working in all the speeds			
Working in all feeds			
Lubrication system			
Coolant system			
Carriage & its travel			
Cross-slide & its movement			
Compound slide & its travel			
Tailstock's parallel movement			
Electrical controls			
Safety gaurds			

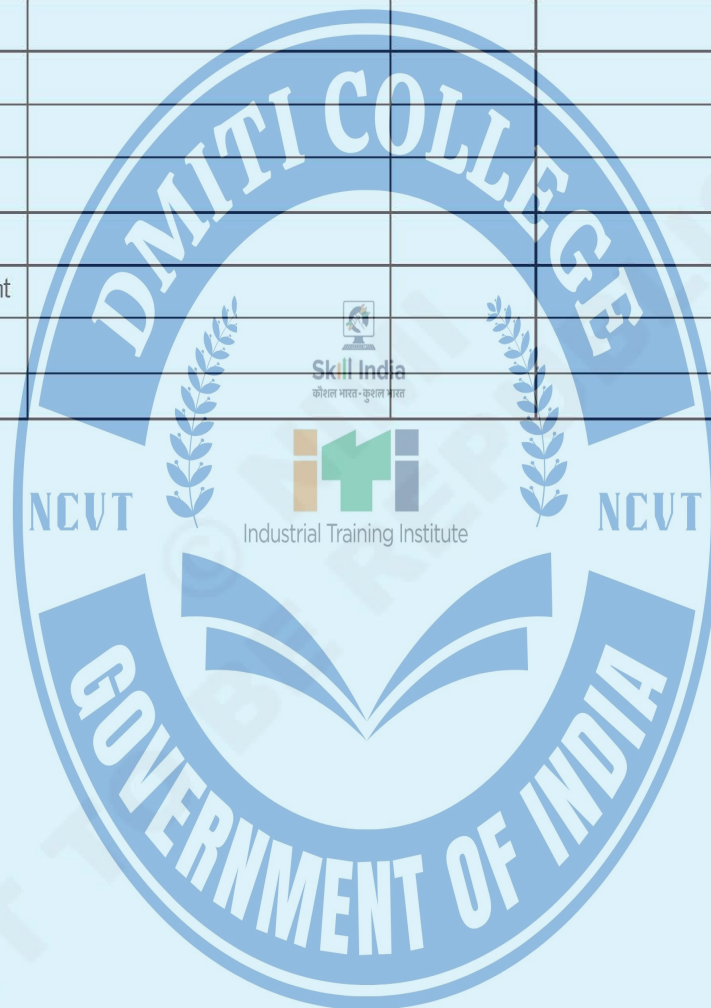

Monitor machine as per routine check list

Objectives: At the end of this exercise you shall be able to

- inspect the lathe parts
- applying lubrication to lathe parts
- operate and check the movements of the machine parts, before machining.

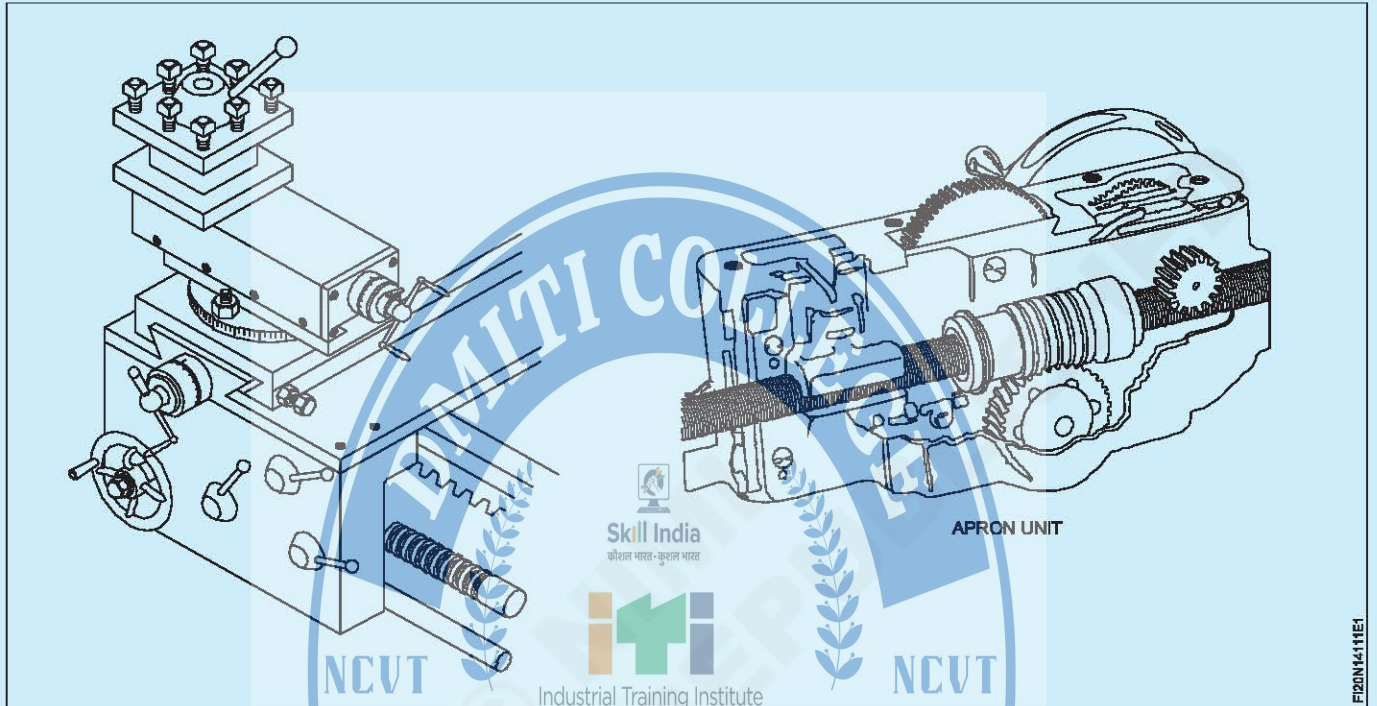

Job Sequence

- Clean the machine.
- Check the safety guards (Fig 1) and ensure that they are in position.
- Check the tension of belt.
- Check the free movement of carriage, tailstock of the lathe.
- Run the machine on different spindle speeds and check.
- Engage the power feed and check the longitudinal and transverse feed movements.
- Check the function of clutches by operating the clutch lever.
- Check the movement of cross slide and the compound slide.
- Check the oil level and functioning of the lubrication.
- Check the coolant and the functioning of the coolant pump.
- Check the exposed gears are fitted properly switch ON and check the running condition of machine before machining.

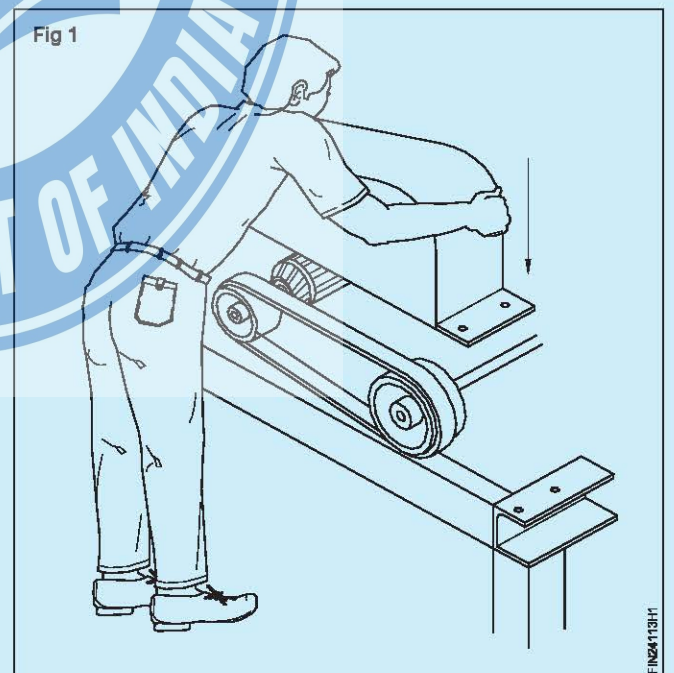

Routine check list of lathe

Table

Items to be checked	Description	Remarks
Belt and its tension		
Bearing sound		
Driving clutch and brake		
Exposed gears		
Working in all the speeds		
Working in all feeds		
Lubrication system		
Coolant system		
Carriage & its travel		
Cross-slide & its movement		
Compound slide & its travel		
Tailstock's parallel movement		
Safety guards		
Adjustment screw		
Quick change gear box		
Feed selector		

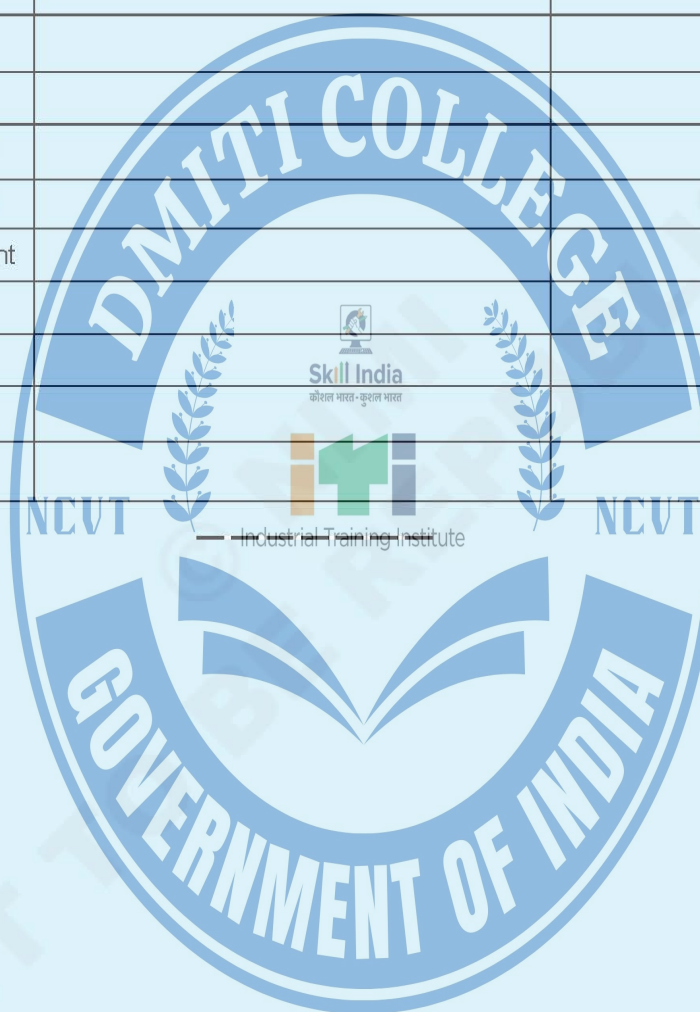

Read pressure gauge, temperature gauge, oil level

Objectives: At the end of this exercise you shall be able to

- read pressure gauge
- read temperature gauge
- check the oil level.

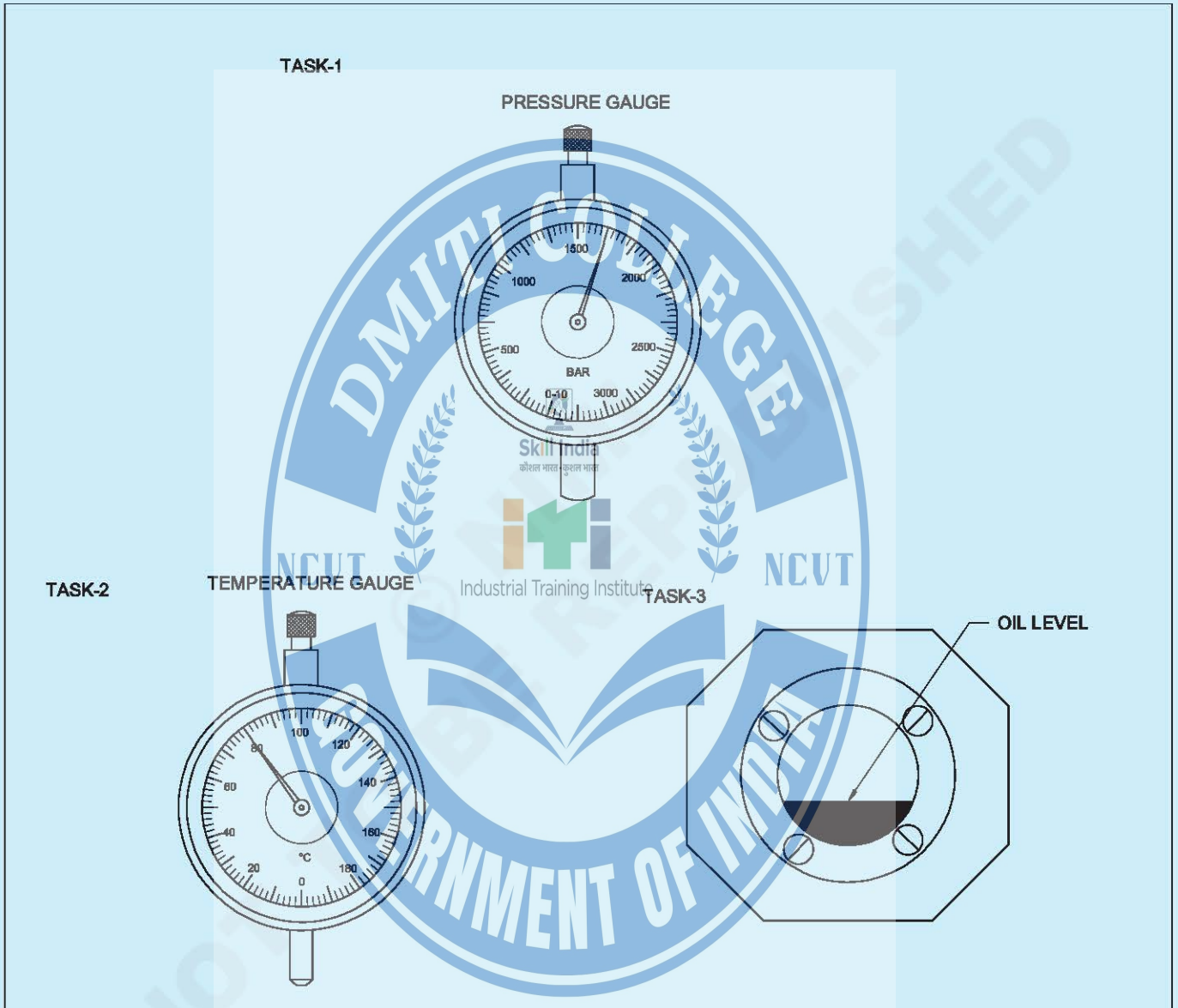

Note: Instructor shall demonstrate to the trainees regarding, reading of pressure gauge, temperature gauge and oil level.

-	-	-	-	-	-	1.8.112
NO.OFF	STOCK SIZE	SEMI-PRODUCT	MATERIAL	PROJECT NO.	PART NO.	EX. NO.
SCALE NTS	READ PRESSURE GAUGE, TEMPERATURE GAUGE,OIL LEVEL				DEVIATIONS	TIME
					CODE NO. F120N18112E1	

Set pressure in pneumatic system

Objectives: At the end of this exercise you shall be able to

- set the pressure relief valve
- check the function of relief valve.

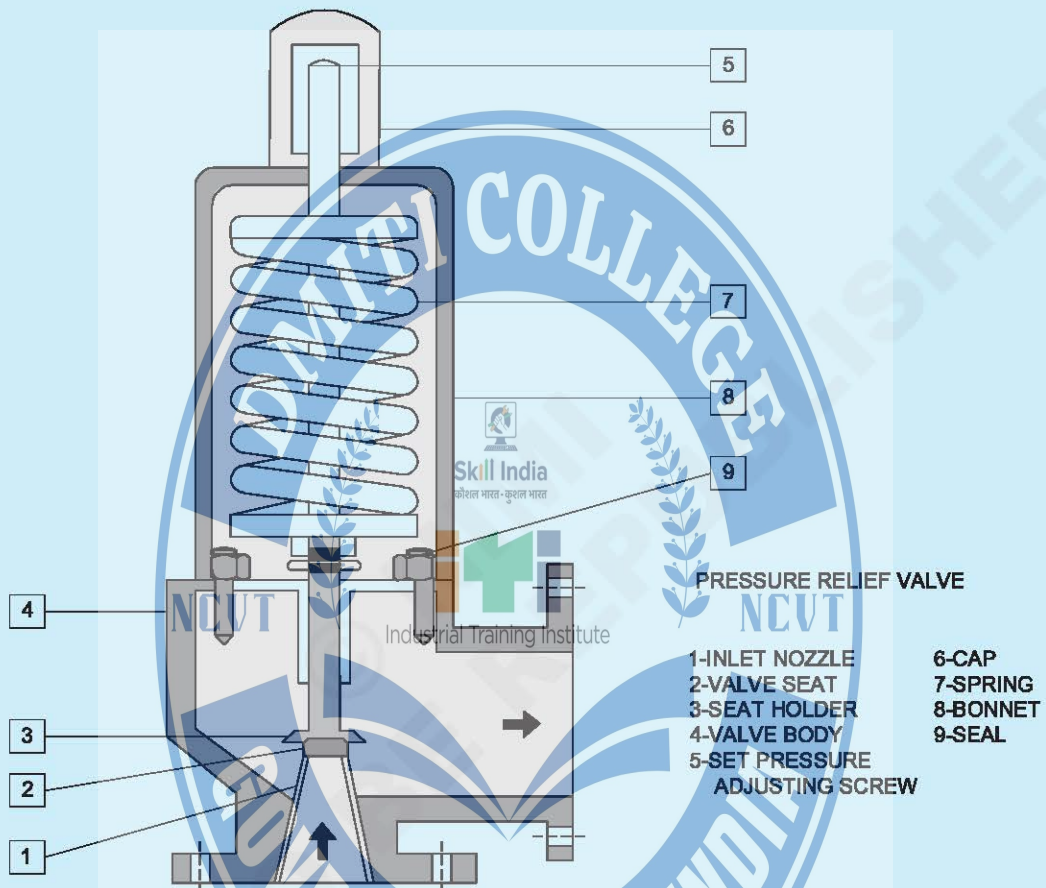

PRESSURE RELIEF VALVE

- 1-INLET NOZZLE
- 2-VALVE SEAT
- 3-SEAT HOLDER
- 4-VALVE BODY
- 5-SET PRESSURE ADJUSTING SCREW
- 6-CAP
- 7-SPRING
- 8-BONNET
- 9-SEAL

Job Sequence

- Switch on the compressor
- Read the pressure gauge in the compressor tank.
- Close the outlet line.
- Check the relief valve function according to the working pressure system
- It not functioning properly, do the following.
 - Open the cap
 - Adjust the set screw No.5 in the Fig.
 - Adjust the set screw according to the required pressure.
 - Check the function of the pneumatic system

-	-	-	-	-	-	1.8.113
NO.OFF	STOCK SIZE	SEMI-PRODUCT	MATERIAL	PROJECT NO.	PART NO.	EX. NO.
SCALE NTS	SET PRESSURE IN PNEUMATIC SYSTEM				DEVIATIONS	TIME
					CODE NO. FI20N18113E1	

Assemble simple fitting using dowel pins and cap screw assembly using torque wrench

Objective: At the end of this exercise you shall be able to
 • prepare and assemble the assembly fit using dowel pins and cap screws.

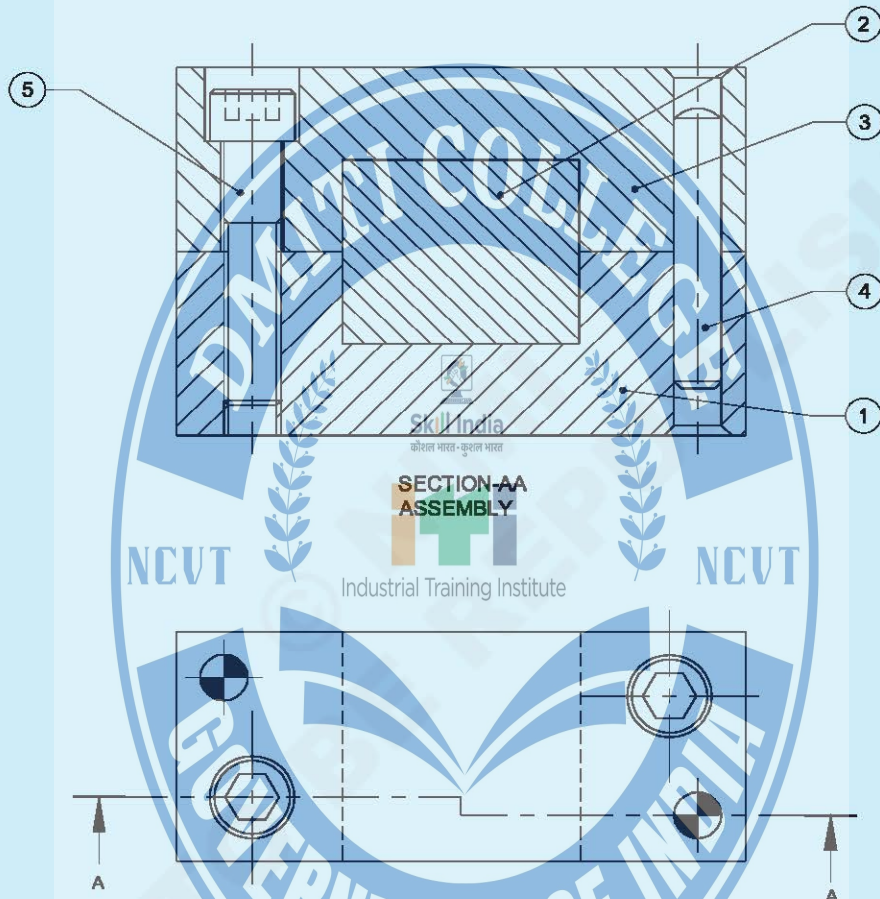

2	M6x30	CAP SCREW	Fe310	-	PART-5	1.8.114
2	Ø5x30	DOWEL PIN	Fe310	-	PART-4	
1	65 ISF 30 - 25	-	Fe310	-	PART-3	
1	SQUARE 28-30	-	Fe310	-	PART-2	
1	65 ISF 30 - 25	-	Fe310	-	PART-1	
NO.OFF	STOCK SIZE	SEMI-PRODUCT	MATERIAL	PROJECT NO.	PART NO.	EX. NO.
SCALE 1:1		ASSEMBLE SIMPLE FITTING USING DOWEL PINS AND CAP SCREW ASSEMBLY USING TORQUE WRENCH			DEVIATIONS ±0.04mm	TIME
					CODE NO. FI20N18114E1	

PART-1 BASE PLATE

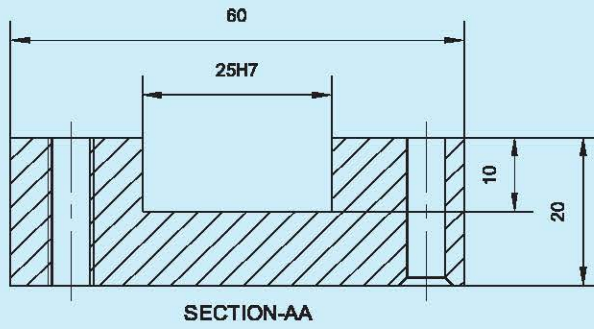

FILED
N7

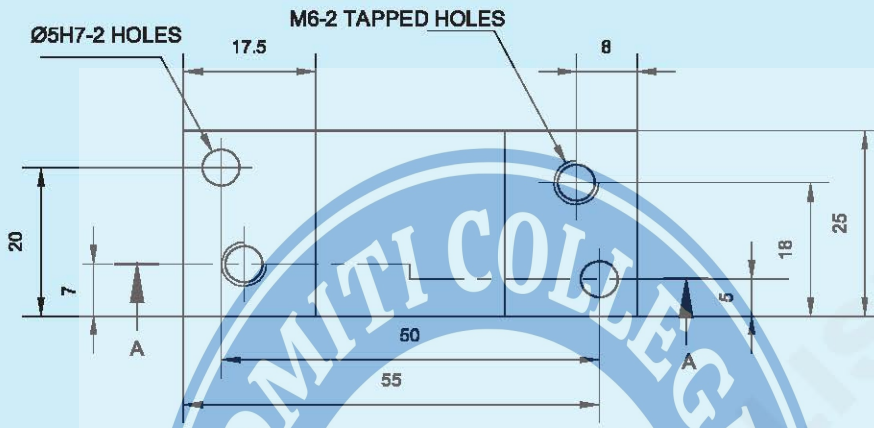

PART-2 MIDDLE PLATE

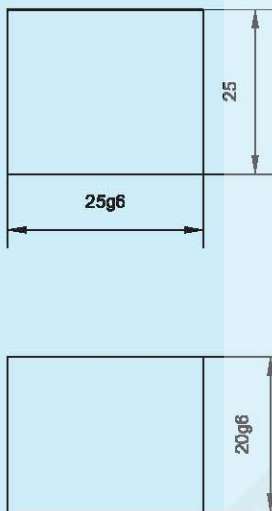

PART-3 TOP PLATE

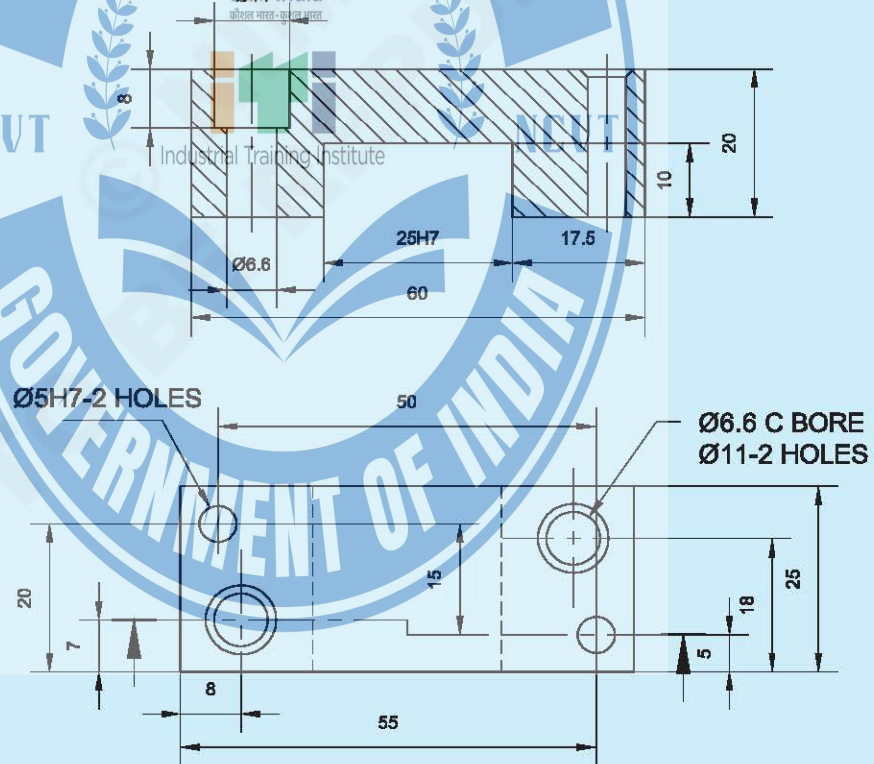

-	-	-	-	-	-	1.8.114
NO.OFF	STOCK SIZE	SEMI-PRODUCT	MATERIAL	PROJECT NO.	PART NO.	EX. NO.
SCALE 1:1					DEVIATIONS	TIME
					<p align="center">BASE PLATE</p> <p align="center">CODE NO.F120N18114E2</p>	

Job Sequence

- Check the raw materials size
- File part 1, 2 and 3 to over all size maintaining parallelism and perpendicularity.
- Check the faultness and squareness with try square and dimensions with vernier caliper.
- Apply marking media on part 1 and 3 and mark the dimensional lines as per drawing.
- Punch witness mark and drill hole marks
- Fit, part 2 in part 1 and 3 maintaining tolerance $\pm 0.04\text{mm}$.
- Assemble, part 1, 2 and 3 all together and clamp it using parallel clamps maintaining squareness.
- Hold the assembly setting in drilling machine table along with suitable fixtures.
- Drill, counter sink and ream the hole as per drawing and fix $\varnothing 5\text{mm}$ dowel pin without disturbing the assembly setting.
- Similarly, drill, counter sink and ream the other dowel pin hole without disturbing the assembly setting and fix other $\varnothing 5\text{mm}$ dowel pin.

Part 1 & 2

- Chain drill, cut and remove the excess metal and file to size and shape as shown Fig 1.

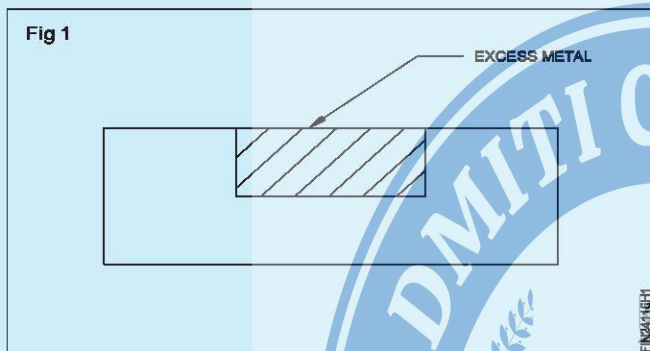

- Similarly, chain drill, cut and remove the excess metal in part 3 and file to size and shape as shown in Fig 2.

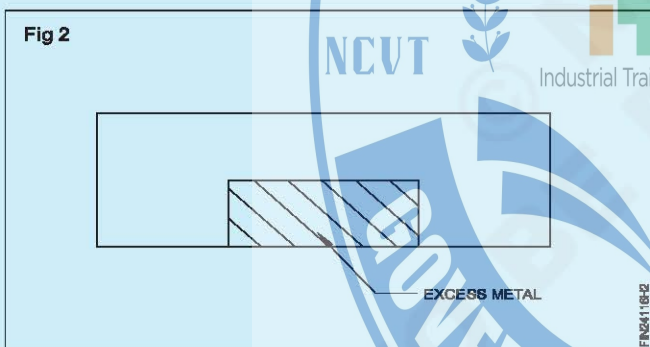

- Drill holes for tapping in part 1 and 3 without disturbing the assembly setting.
- Separate the assembly setting, drill $\varnothing 6.6\text{mm}$ through hole and $\varnothing 11\text{mm}$ counter bore to the depth of 8mm in part 3 to enter the cap head screws as shown in job drawing.
- Hold part 1 in bench vice and cut M6 internal thread in two holes to fix cap head screws.
- Clean the threads without burrs.
- Finish file in part 1, 2, 3 and de-burr in all corners of the job.
- Re-assemble part 1 and 3 along with dowel pins and cap screws.
- Fix the cap screws using torque wrench.
- Fit, part 2 in part 1 and 3 opening slot.
- Apply a little oil and preserve it for evaluation.

Skill Sequence

Fixing of dowel

Objectives: This shall help you to

- fix dowel pins
- remove dowel pins.

Keep position 1 and position 2 as shown in Fig 1.

Tighten the socket head screw such that there is a gap of one pitch of the socket head screw as shown in Fig 1.

Drive the dowel using a hammer such that about 5 mm of the chamfer side of the dowel enters into the reamed hole as shown in Fig 2.

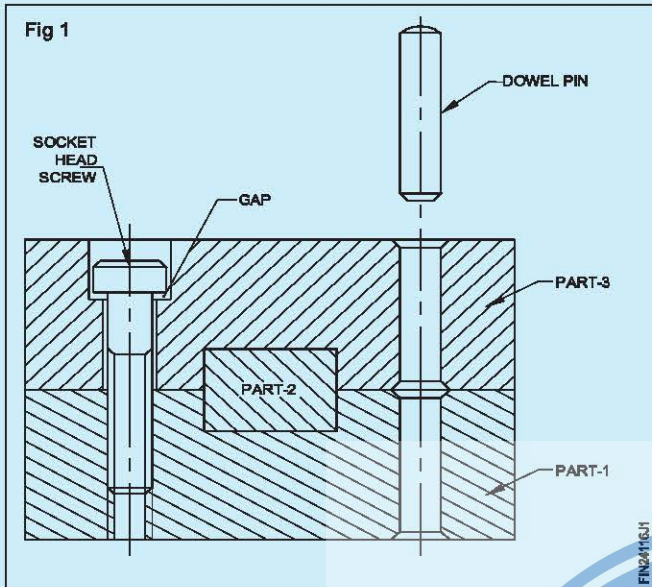

Drive the dowel keeping pin punch dia 5.8 over the radius of the end of the dowel such that the chamfered end of the dowel into position 2 as shown in Fig 4.

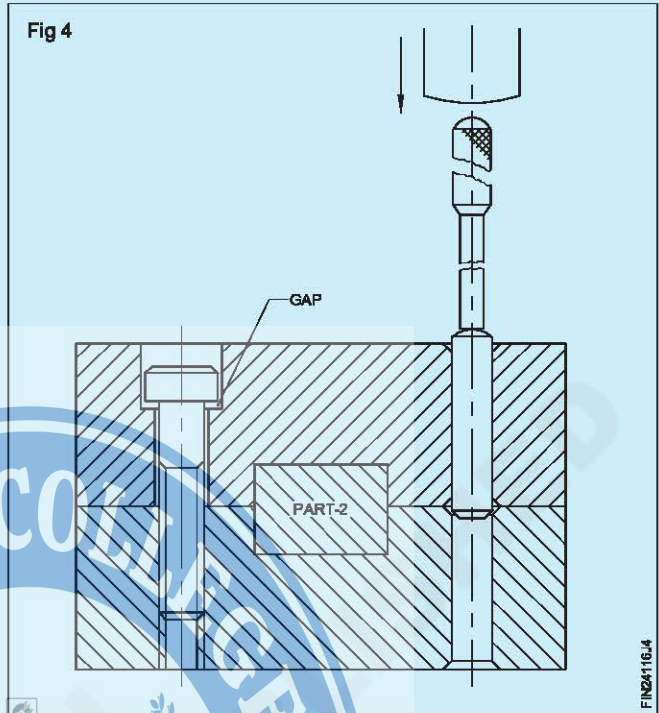
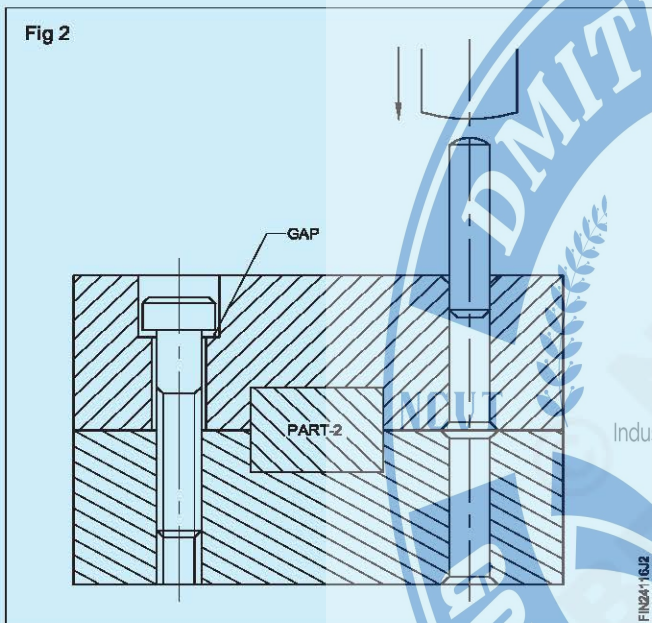

Drive the dowel in about 10 mm into position 2 as shown in Fig 5.

Check for the perpendicularity.

Drive the dowel into the reamed hole such that chamfered end of the dowel enters fully into the position 1 as shown in Fig 3.

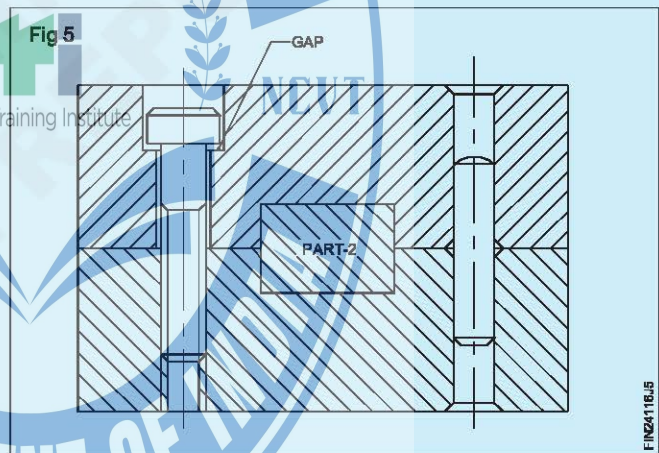
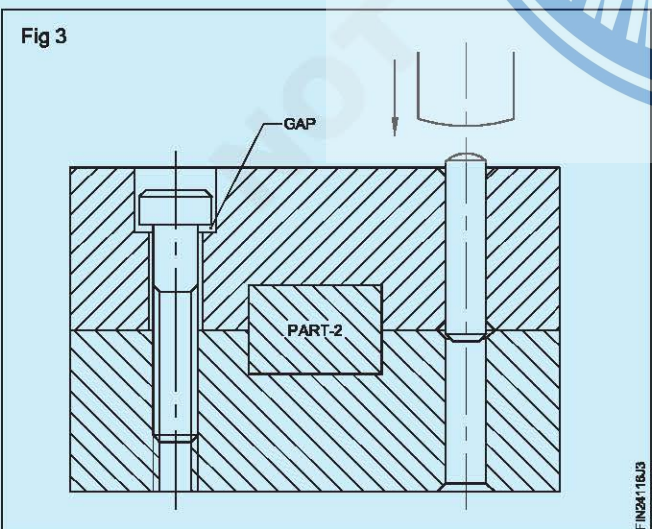

Tighten the socket head screw such that there is no gap exists as shown in Fig 6.

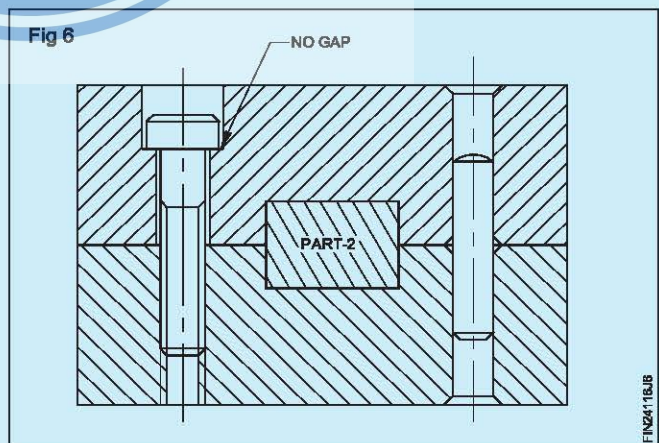

Removal of the dowel

Removal of the dowel should be in the same direction as driving.

Insert pin punch into the reamed hole such that it sits over the radius end of the dowel as shown in Fig 7.

Knock the dowel out using the hammer as shown in Fig 8.

