

**Instruments - Scales - Classification - Forces - MC and MI meter**

**Objectives:** At the end of this lesson you shall be able to

- state the instrument, position, types
- state the terminal markings in instrument
- state the instrument scales type.

**Electrical Measuring Instrument**

Electrical measuring instruments (meters) is an apparatus, used for measuring the electrical quantities like current, voltage, resistance power and energy etc.

**Identification of instrument**

The instrument should be identified for the quantity to be measured, the range, suitability for a particular type of supply etc. by carefully going through the data available on the dial.

**Types of current:** The types of supply on which the instrument is suitable for measurement is indicated by symbols as follows.

—	Direct current
~	Alternating current
⌋	Direct and alternating current

**Testing potential (voltage):** The star mark on the dial indicates the voltage to which the instrument is subjected for test.

	Testing potential 500V
	Testing potential over 500V eg, 2000V(2KV)

**Using position:** Instruments must be used as per the specified position mentioned on the dial.

	Vertical using position.
	Horizontal using position.
	Angle of usage eg. 60° tilt angle.

**Instruments used in any position other than the one specified may cause error in reading.**

**Measuring instrument types**

	Moving coil instrument
	Moving iron instrument
	Electrodynamic quotient instrument
	Moving coil instrument with rectifier

**Indication error:** Instruments are manufactured to read within certain accuracy. This is indicated on the dial by a number close to the other symbols.

1	Indication error $\pm 1\%$
2.5	Indication error $\pm 2.5\%$
3.5	Indication error $\pm 3.5\%$

**Terminal markings:** In a moving coil type of instrument, the terminals are marked with + and - . The positive (+) terminal is red in colour and the negative(-) terminal is black in colour (Fig 1). This type of instrument must be connected in the circuit with correct polarity. i.e. the +ve of supply to the +ve of instrument and the -ve of supply to the -ve of the instrument.

In the moving iron type there is no polarity marking on the terminals. Both the terminals are of the same colour. The instrument can be connected in the circuit without identifying the line and neutral of the supply.

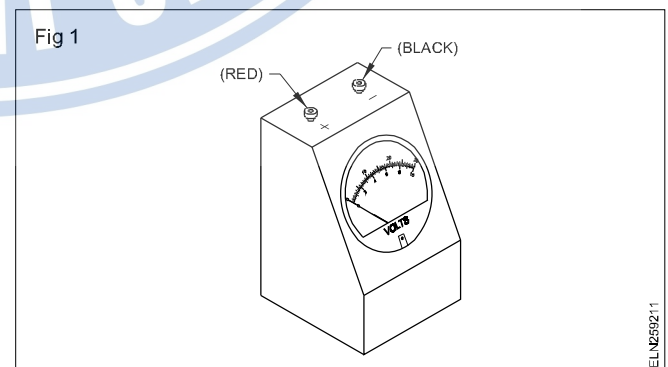

# Classification of electrical instruments - Essential forces, MC and MI meter

**Objectives:** At the end of this lesson you shall be able to

- **classify electrical instruments with respect to standard, function and operation by the effect of electric current**
- **explain the type of forces required for the proper functioning of an electrical indicating instrument.**

Electrical instruments may be classified based on the following.

- Manufacturing standards
- Function
- Effects of electric current on the instruments.

**Manufacturing standards:** The electrical instruments may, in a broad sense, be classified according to the manufacturing standards into absolute instruments and secondary instruments.

**Absolute instruments:** These instruments give the value of quantity to be measured in terms of deflection and instrument constants. A good example of an absolute instrument is the tangent galvanometer (Fig 1).

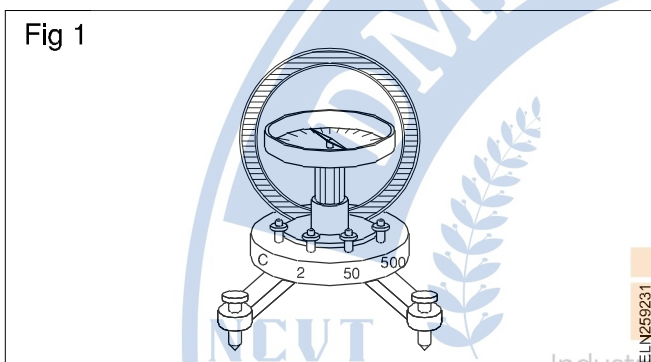

These instruments are used only in standard laboratories.

**Secondary instruments:** In these instruments the value of electrical quantity (voltage, current, power, etc.) to be measured can be determined from the deflection of the instruments on the calibrated dial. These instruments should be calibrated in comparison with either an absolute instrument or with one which has already been calibrated. All the instruments used commercially are secondary instruments.

## Functions

Secondary instruments are further classified according to their functions, that is, whether the instrument indicates, or records the quantity to be measured. Accordingly, we have indicating, integrating and recording instruments.

**Indicating instruments:** These instruments (Figs 2) indicate the value of voltage, current power etc., directly on a graduated dial. Ammeters, voltmeters and wattmeters belong to this class.

**Integrating instruments:** These instruments measure the total amount, either the quantity of electricity or the electrical energy, supplied to a circuit over a period of time. Ampere hour meters and energy meters belong to this class. Fig 3 shows the Kilowatt hour/energy meter.

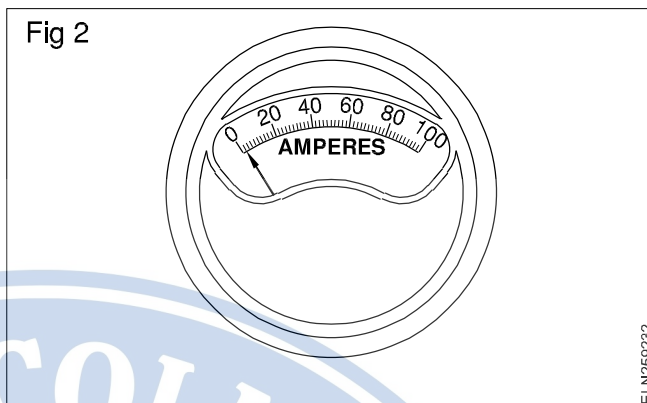

**Recording instruments:** These instruments register the quantity to be measured in a given time, and are provided with a pen which moves over a graph paper. With this instrument, the quantity can be checked for any particular date and time. Recording voltmeters, ammeters and power factor meters belong to this class. Fig 4 shows such a recording instrument.

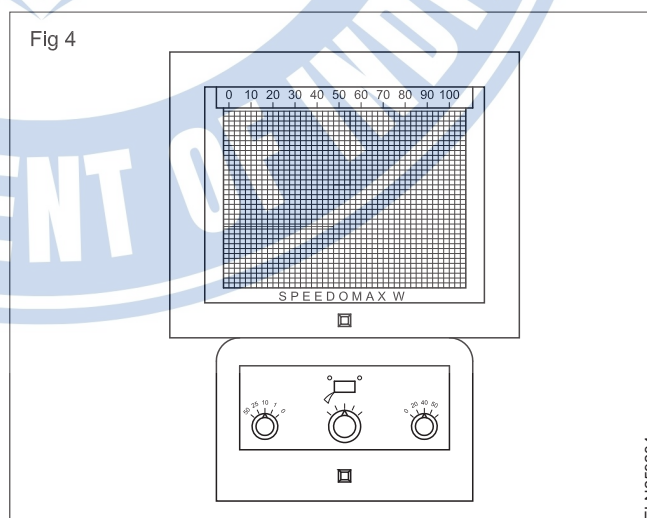

**Effects of electric current used on electrical instruments:** Secondary instruments may also be classified according to the various effects of electricity

upon which their operation depends. The effects utilised are as follows.

- Magnetic effect
- Heating effect
- Chemical effect
- Electrostatic effect
- Electromagnetic induction effect

**Essential forces required for an indicating instrument:**

The following three forces are essential requirements of an indicating instrument for its satisfactory operation. They are

- deflecting force
- controlling force
- damping force.

**Deflecting force or operating force:** This causes the moving system of the instrument to move from its 'zero' position, when the instrument is connected to the supply. To obtain this force in an instrument, different effects of electric current, such as magnetic effect, heating effect, chemical effect etc. are employed.

**Controlling force:** This force is essential to control the movement of the moving system and to ensure that the magnitude of the deflection of the pointer is always the same for a given value of the quantity to be measured. As such, the controlling force always acts opposite to the deflecting force, and also brings the pointer to zero position when the instrument is disconnected from the supply.

The controlling force could be produced by any one of the following ways.

- Gravity control
- Spring control

**Gravity control:** In this method, small adjustable weights are attached to the opposite extension of the pointer (Fig 5). These weights are attracted by the earth's gravitational pull, and thereby, produce the required controlling force (torque). The instruments with gravity control are to be used in the vertical position only.

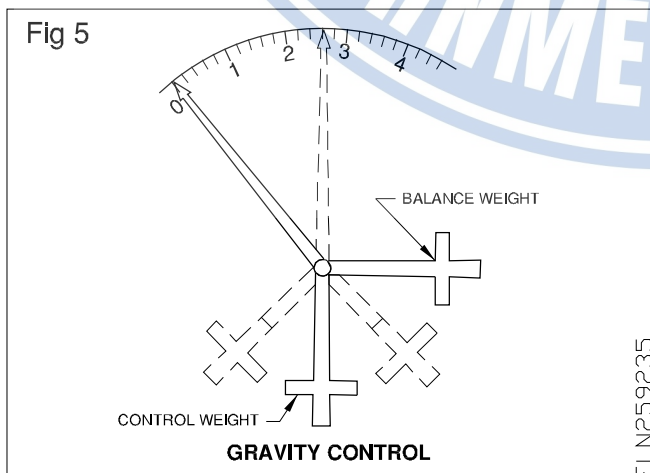

When the instrument is not connected to the supply, the control weight and the balance weight attached to the opposite end of the pointer make the pointer to be at zero position (Fig 5). When the instrument is connected to the supply, the pointer moves in a clockwise direction, thereby displacing the weights (Fig 5). Due to the gravitational pull, the weights will try to come to their original vertical position, thereby exerting a controlling force on the movement of the moving system.

**Spring control:** The most common arrangement of spring control utilises two phosphor-bronze or beryllium-copper spiral hair-springs A and B, the inner ends of which are attached to the spindle S (Fig 6). The outer end of the spring B is fixed, whereas that of A is attached to the end of a lever 'L' pivoted at P, thereby enabling the zero adjustment to be easily effected when needed.

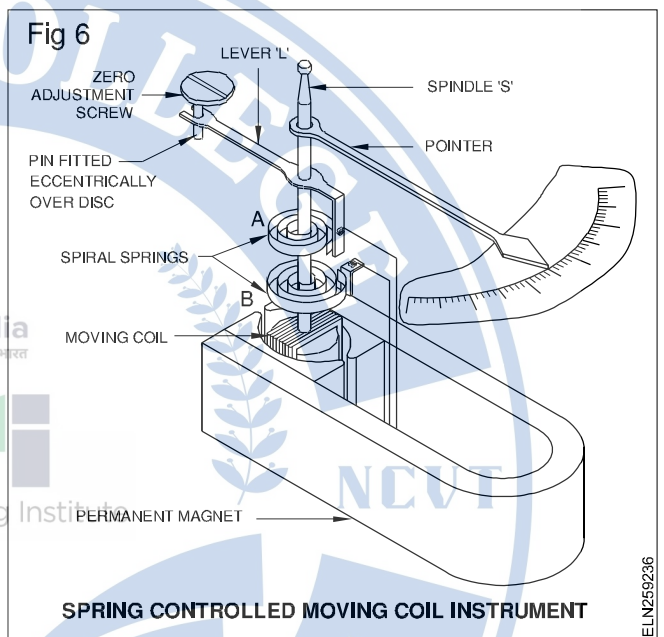

The two springs A and B are wound in opposite directions so that when the moving system is deflected, one spring winds up while the other unwinds, and the controlling force is due to the combined torsions of the springs.

These springs are made from such alloys that they have:

- non-magnetic properties (should not get affected by external magnetism)
- low temperature coefficient (do not elongate due to temperature)
- low specific resistance (can be used for leading current 'in' and 'out' of the moving system).

Spring controlled instruments have the following advantages over the gravity controlled instruments.

They are:

- the instruments can be used in any position
- the control springs help in leading in and out the current to the moving coil of the instruments.

**Damping force:** This force is necessary to bring the moving system to rest in its final deflected position quickly. Without such damping, the combination of the inertia of the moving system and the controlling force makes the pointer (moving system) to oscillate about its final deflected position for some time before coming to rest, resulting in a waste of time in taking the reading.

The two methods of damping, commonly employed are:

- eddy current damping
- air friction damping.

**Eddy current damping:** Fig 7 shows one form of eddy current damping. A copper or aluminium disc D, is attached to the spindle 'S'. When the pointer moves, the disc also moves.

The disc is made to move in the air gap between the poles of a permanent magnet M. The moving disc cuts the flux, thereby inducing eddy currents in the disc. According to Lenz's law, the flux produced by the eddy current opposes the movement of the disc, thereby effecting the damping force.

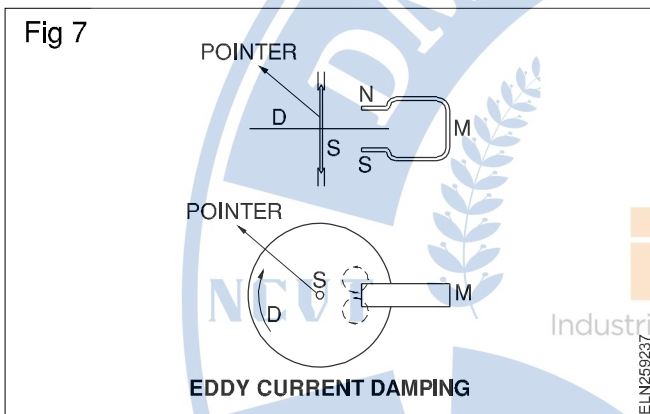

In the case of moving coil instruments, the moving coil is wound on a thin aluminium former. The eddy currents induced in the former produces the damping force.

**Air friction damping:** Fig 8 shows the method of obtaining air friction damping. Accordingly a thin metal vane V is attached to the spindle S, and the vane is made to move inside a sector shaped box 'e' while the pointer moves on the graduated scale.

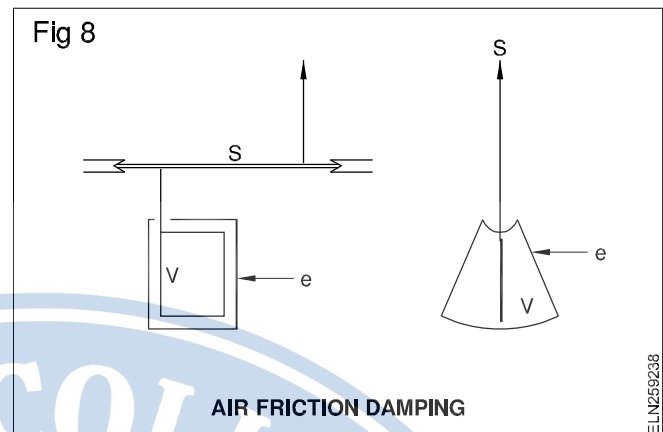

Alternatively, the vane in the form of a piston could be arranged to move inside an air chamber (cylinder) as shown in Fig 9. In the above two cases, the air inside the air chamber opposes the movement of the vane/piston, and, thereby, the damping force is created.

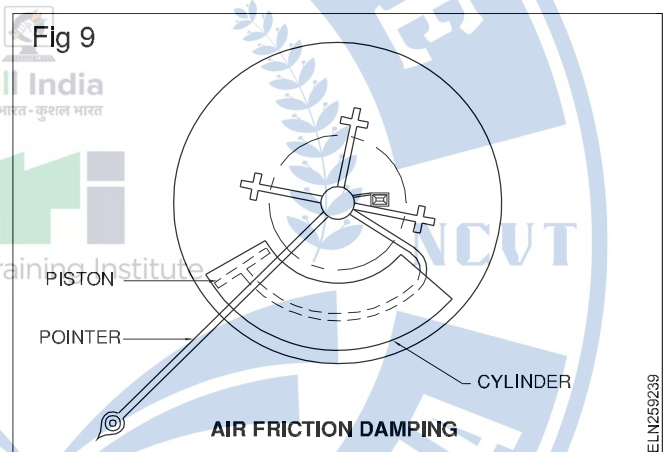

## Permanent magnet moving coil (PMMC) instruments

**Objectives:** At the end of this lesson you shall be able to

- state the principle of a permanent magnet moving coil (P.M.M.C) instrument
- describe the construction and operation of a P.M.M.C instrument
- state the uses, advantages and disadvantages of a P.M.M.C instrument.

### Moving Coil and Moving Iron Instruments :

Instruments are classified based on their moving system They are :

#### (i) Moving Coil Instruments (MC)

Permanent Magnet Moving Coil Instrument (PMMC)

Dynamo meter type instruments

#### (ii) Moving Iron Instruments (MI)

Attraction type

Repulsion type

The most commonly used instrument to measure DC quantities like voltage and current, is the permanent magnet moving coil (PMMC) instrument.

### Permanent magnet moving coil (PMMC) instruments

The most commonly used instrument to measure DC quantities like voltage and current, is the permanent magnet moving coil (PMMC) instrument.

**Principle:** The working of the PMMC instrument is based on the principle that when a current-carrying conductor is placed in a magnetic field, it is acted upon by a force which tends to move the conductor. The DC motor also works on this principle.

**Construction:** The PMMC instrument consists of a permanent magnet and a rectangular coil wound with a very fine gauge insulated copper wire on a thin light aluminium former.

The aluminium former not only supports the coil, but also produces eddy current for damping. The coil and the former are attached with spindles on either side, and supported by jewelled bearings so as to make the assembly move freely in the air gap (Fig 1).

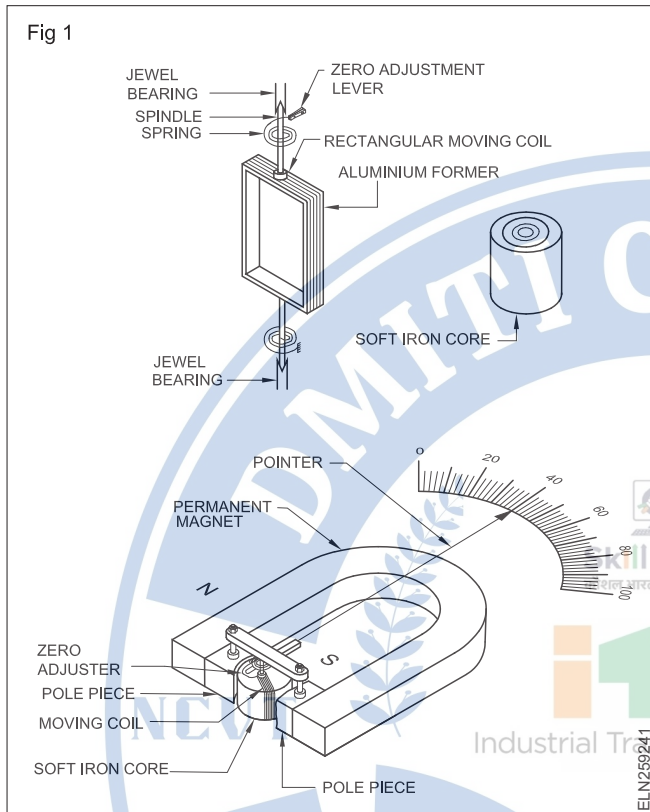

The two ends of the coil are connected to two phosphor-bronze springs, fixed one on each spindle to lead in and lead out the current. The springs are spiralled in the opposite direction in order to neutralize the effect of temperature changes.

The horseshoe shaped permanent magnet is made of an alloy called 'Alnico' and it has soft iron pole pieces which are shaped to distribute uniform flux in the air gap.

A soft iron core is fixed in such a way that the moving coil can move within the gap, between the soft iron core and the pole pieces. The function of the soft iron core is (i) to decrease the reluctance of the magnetic path between the poles and thereby increase the magnetic flux and (ii) to make the flux uniformly distributed in the air gap.

The pointer is attached to one of the spindles, and it moves on a graduated scale when the coil is deflected by the quantity to be measured.

**Operation:** When the current is passed through the coil, the coil experiences a force due to the interaction of the magnetic fluxes, produced by the permanent magnet and the current in the moving coil.

We have the force 'F' in the coil equal to  $BLIN$  Newtons  
Fig 2

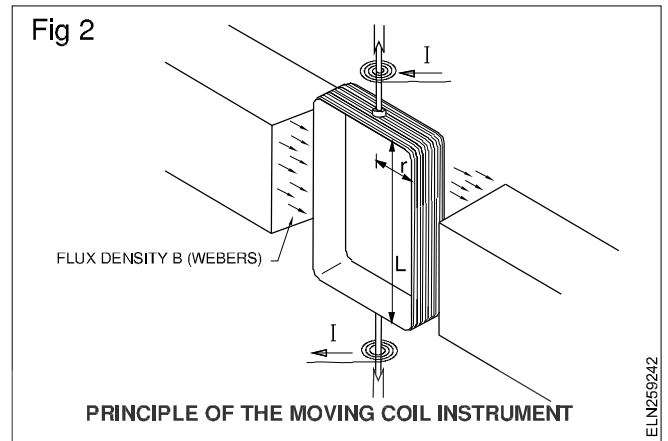

where

- B - The flux density in the air gap in Webers/square metre,
- L - The active length of one conductor in the air gap in metres
- I - The current in amperes passing through the coil and N is the number of turns.

Torque produced in the coil

= force X perpendicular distance between the centre of the conductor to the centre of the spindle in metres.

Let us assume the distance as 'r' metres.

Hence we have

$$T = Fr \text{ Newton metres}$$

$$T = BLINr \text{ Newton metres.}$$

$$(F = BLIN \text{ Newton})$$

But B, L, N and r are constants for a particular instrument and can be denoted by a letter 'K'. As such

$$\text{Torque} = KI$$

Torque proportional to I

From the above equation we can infer that the deflecting torque of a PMMC instrument is directly proportional to the current, and, therefore, the scale of the PMMC instrument is uniform that is the scale in which the space between numbers are equal.

Hence, while connecting the instrument in DC the polarity should be correctly observed. Further the instrument will not deflect when connected to an AC supply.

The PMMC instrument could be directly used to measure milli or micro amperes as the moving coil can carry a low current only. With proper shunts, this instrument could be used to measure large currents, and with proper series resistors, called multipliers, it could be converted into a voltmeter.

**Advantages:** The PMMC instrument

- consumes less power
- has uniform scale and can cover an arc up to 270°
- has high torque/weight ratio

- can be modified as voltmeter or ammeter with suitable resistors
- has efficient damping
- is not affected by stray magnetic fields, and
- has no loss due to hysteresis.

- is very delicate
- is costly when compared to a moving iron instrument
- may show errors due to loss of magnetism of the permanent magnet.

**Uses:** It can be used as volt meter and Ammeter

**Disadvantages:** The PMMC instrument

- can be used only in DC

## Moving-iron instruments

**Objectives:** At the end of this lesson you shall be able to

- state the principle of moving-iron instruments - attraction and repulsion type
- describe the construction and working of a moving-iron instrument
- state the use, advantages and disadvantages of moving-iron instruments.

**Moving-iron instruments:** This instrument derives its name from the fact that a piece of soft iron which is attached to the spindle and needle moves in a magnetic field, produced by the current or by a current proportional to the quantity of electricity being measured.

There are two types of this instrument which are used either as voltmeter or ammeter.

They are:

- attraction type
- repulsion type.

**Principle of operation:** The attraction type instrument works on the principle of magnetic attraction, and the repulsion type instrument works on the principle of magnetic repulsion between two adjacent pieces of soft iron, magnetised by the same magnetic field.

**Construction and working of attraction type moving-iron instrument:** This instrument consists of an electromagnetic coil having an air core (Fig 1). Just in front of the air core, an oval shaped soft iron piece is eccentrically pivoted in a spindle (Fig 1).

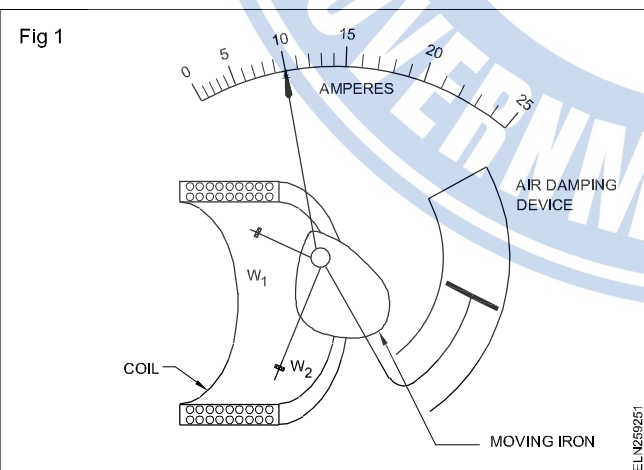

The spindle is free to move with the help of the jewelled bearings, and the pointer, which is attached to the spindle, could thus move over the graduated scale. When the electromagnetic coil is not connected to the circuit, the soft iron piece hangs vertically down, due to gravitational force and the pointer shows zero reading.

When the electromagnetic coil is connected to the supply, the magnetic field created in the coil attracts the soft iron piece (Fig 1). Due to the eccentricity of pivoting of the iron piece, the enlarged portion of the iron piece is pulled towards the coil. This in turn moves the spindle and makes the pointer to deflect.

The amount of deflection of the pointer will be greater when the current producing the magnetic field is greater. Further the attraction of the soft iron piece is independent on the current direction in the coil. This characteristic enables the instrument to be used both in DC and AC.

**Construction and working of repulsion type moving-iron instrument:** This instrument consists of a coil wound on a brass bobbin B, inside which two strips of soft iron M and F are set axially (Fig 2a). Strip F is fixed whereas the iron strip M is attached to the spindle S, which also carries the pointer P.

Spring control is used, and the instrument is designed such that when no current is flowing through W, the pointer is at zero position and the soft iron strips M and F are almost touching. (Fig 2a & 2b)

When the instrument is connected to the supply, the coil W carries current which in turn produces a magnetic field. This field makes the fixed and moving-iron F and M respectively to produce similar poles in the ends. Therefore, the two strips repel each other.

The torque set up produces a deflection of the moving system end. Therefore it brings into play a controlling torque due to torsion of the control springs or weights. The moving system comes to rest in such a position that the deflecting and controlling torques are equal.

In this type of instrument, air damping is used commonly which is provided by the movement of a piston  $P_N$  in a cylindrical air chamber C (Fig 2a).

**Deflecting torque and graduation of scale:** However, in the moving-iron instruments, the deflecting torque is proportional to the square of the current passing through the coil. As such the scale of this instrument will be uneven. It is cramped at the beginning and open at the end (Fig 3).

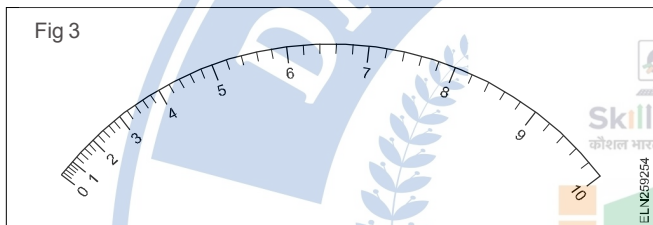
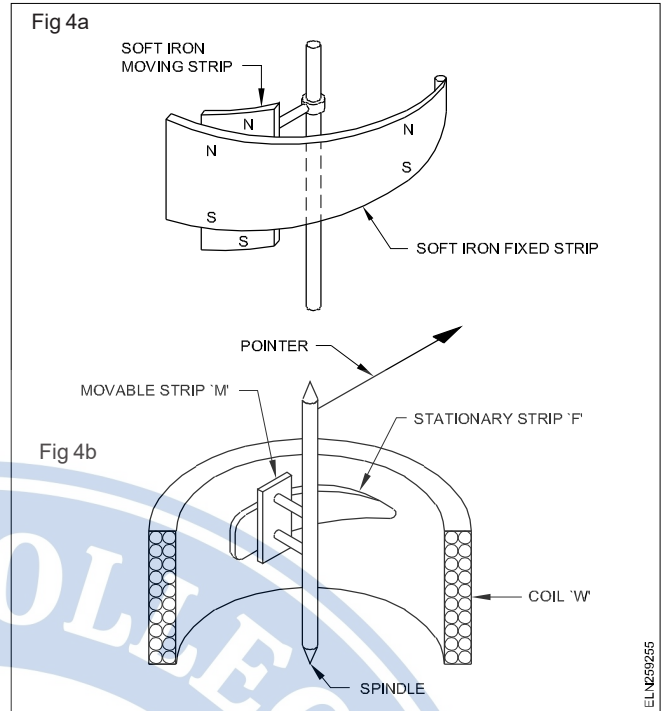
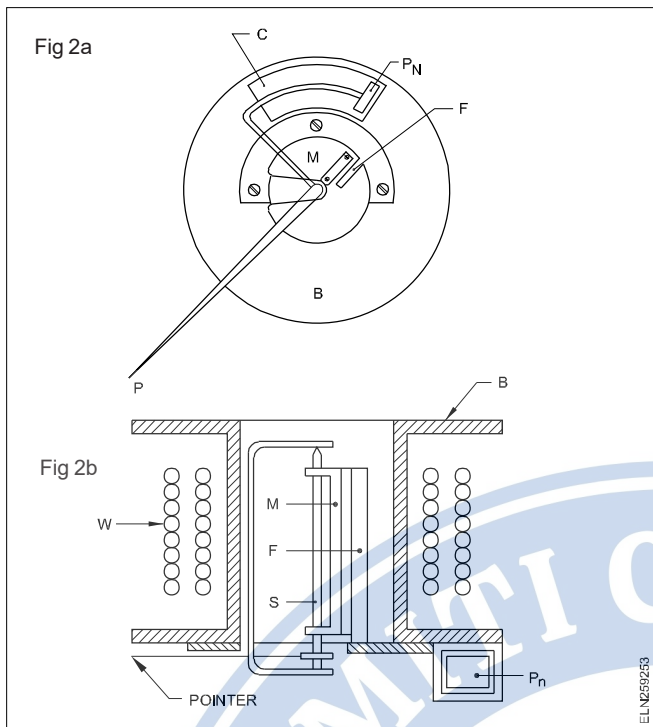

In order to achieve uniformity of scale, some manufacturers have designed tongue shaped strip as fixed soft iron (Fig 4a).

The fixed iron consists of a tongue-shaped soft iron sheet bent into a cylindrical form, while the moving iron is made of another soft iron sheet, and is so mounted as to move parallel to the fixed iron and towards its narrower end (Fig 4b).

The torque, which is proportional to the square of the current, is proportionally reduced by the narrow portion of the fixed iron, resulting in more or less even torque and thereby uniform scale.

These instruments are either gravity or spring controlled, and the damping is achieved by the air friction method.

### Uses, advantages and disadvantages of Moving-iron instruments

**Uses:** They are used as voltmeters and ammeters.

**The coil W is wound with thick conductor of less number of turns for ammeters and is wound with thin conductors of large number of turns for voltmeter.**

### Advantages

- They can be used for both AC and DC, and are hence called unpolarized instruments.
- They have a small value of friction errors as the torque/weight ratio is high.
- They are less costly when compared to the moving coil instruments.
- They are robust owing to their simple construction.
- They have satisfactory accuracy levels within the limits of both precision and industrial grades.
- They have scales covering 240°.

### Disadvantages

- They have errors due to hysteresis, frequency changes, wave-form and stray magnetic fields.
- They have non-uniform scales commonly. However, special manufacturing designs are utilized to get more or less uniform scales.

# Dynamometer type instrument

**Objectives:** At the end of this lesson you shall be able to

- state the principle of dynamometer type instrument
- describe the construction, and working of the dynamometer type instruments
- explain the internal connections of a dynamometer instrument when used as a voltmeter, ammeter and wattmeter
- state the advantages and disadvantages of using the dynamometer instruments.

## Electro-dynamic or Dynamo-meter type Instruments

**Working principle:** This Instrument works on the principle of DC motor. That is, whenever a current-carrying conductor is kept in a magnetic field, a force is created and it tends to move the conductor away from the magnetic field. In a dynamometer instrument, the magnetic field is produced by an electromagnet named as fixed coils.

The moving coil, either connected in series or parallel with the fixed coil, carries a proportionate current. Operation of this instrument in both AC and DC is possible due to the fact that when ever the current reverses in AC, the direction of flux in the fixed coils as well as the direction of flux produced by moving coil, reverses at the same time resulting in the same direction of torque.

**Construction:** A general arrangement of the instrument is shown in Fig 1. The main magnetic field is produced by the fixed/stationary coil. This coil is divided into two sections to give a uniform field in the centre and also to allow the moving coil mechanism to be placed in between them.

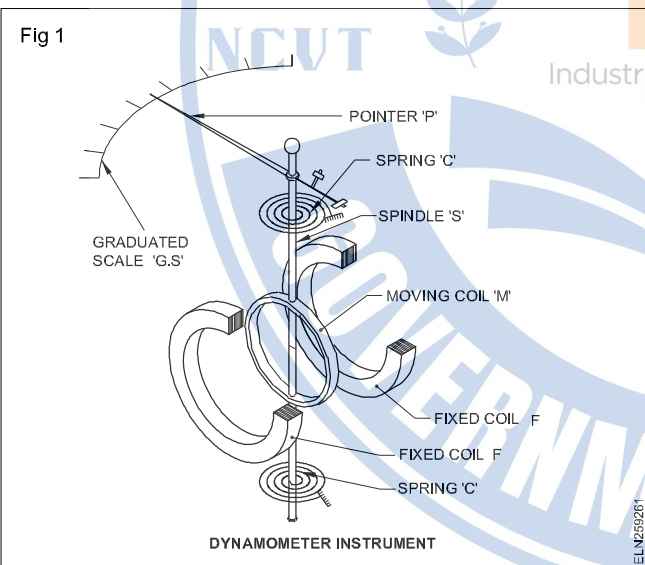

The fixed coils F and F are placed close together and parallel to each other (Fig 2). The air core section removes hysteresis effects when used in AC circuits. The moving coil 'M' is mounted on a spindle 'S' and the spindle is free to move in the air gap with the help of jewelled bearings.

The pointer 'P' is attached to one end of the spindle and the spindle end made to move on a graduated scale 'G.S.'. The controlling torque is provided by two phosphor-bronze springs 'C' attached to the spindle. Further the springs are used to allow the current 'in' and 'out' from the moving coil.

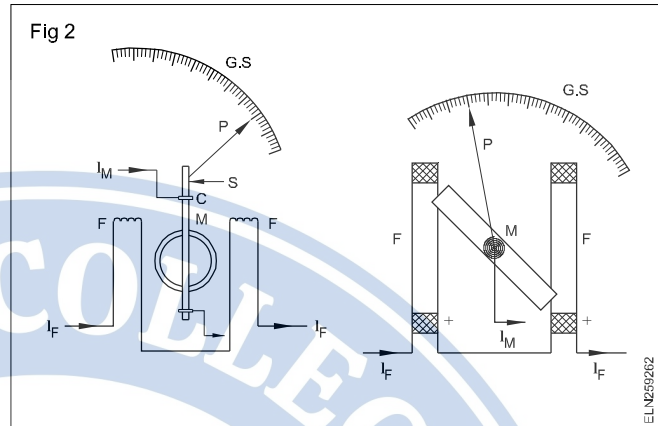

**Working:** As shown in Fig 3, let the current passing through the fixed coils be  $I_F$ , and the current passing through the moving coil be  $I_M$ . The field strength will be proportional to the current  $I_F$ .

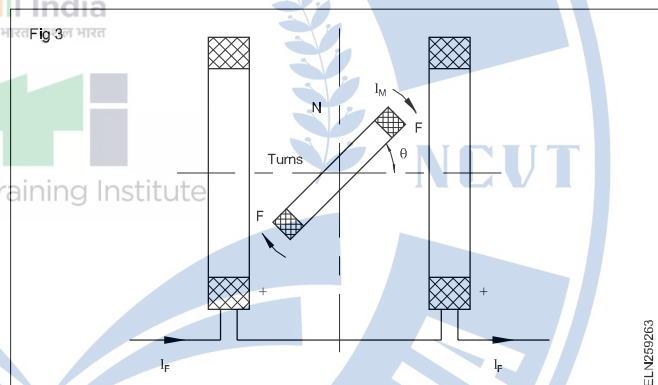

The deflecting torque is produced due to the interactions of the magnetic fields produced by the fixed and moving coils and will be proportional to the current carried by them.

The deflecting torque  $T_d$  is proportional to  $I_F$  and  $I_M$  where  $I_F$  is the current in the fixed coil and  $I_M$  is the current in the moving coil.

From the above torque equation, it is clear that the instrument when used as voltmeter or ammeter will have ununiform scale due to the square law response.

However, when used as a wattmeter, the instrument will have uniform scale.

Connection of this instrument requires modification depending up on the usage viz, ammeter, voltmeter or wattmeter as explained below.

**Dynamometer instrument as an ammeter:** This instrument could be used as milli or micro ammeter by connecting the fixed and moving coils in series (Fig 4).

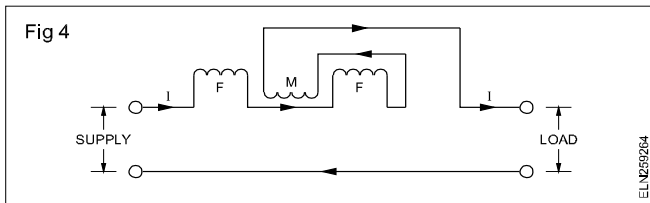

As the moving coil is made by winding small gauge (thin) wire, the above connection is unsuitable for measuring heavy currents.

When the instrument is to be converted as an ammeter to measure large currents, the moving coil is connected across a shunt (Fig 5). Both AC and DC, measurements are possible.

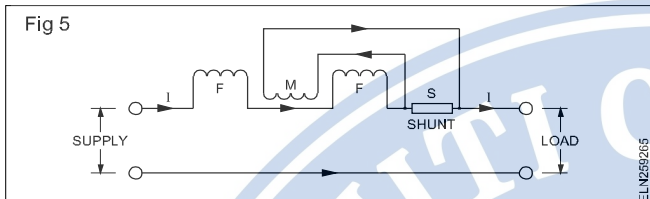

## Digital Ammeter

**Objectives:** At the end of this lesson you shall be able to

- state the features of digital ammeter
- state the movements, special operation and standard.

### Digital Ammeter

Digital Ammeters are instruments that measure the current in ampere and display it in digital. These instruments provide information about current drawn and current continuity to help users troubleshoot electric loads.

They have both positive and negative leads and low internal resistance. Digital ammeters are connected in series with a circuit so that current flow passes through the meter.

It can be used to measure the A.C and D.C. Many digital ammeters include a current sensor built in the meter.

#### Features:

Different types of digital ammeters can measure different ranges of A.C current and D.C current and also A.C frequency.

Batteries are provided in it to operate without plug-in-power and suitable for outdoor use Fig 1 shows a typical digital ammeter.

**Dynamometer instrument as a voltmeter:** When this instrument is used as voltmeter, the fixed and moving coils are joined in series along with a high resistance (multiplier) (Fig 6). This voltmeter could be used both in AC and DC.

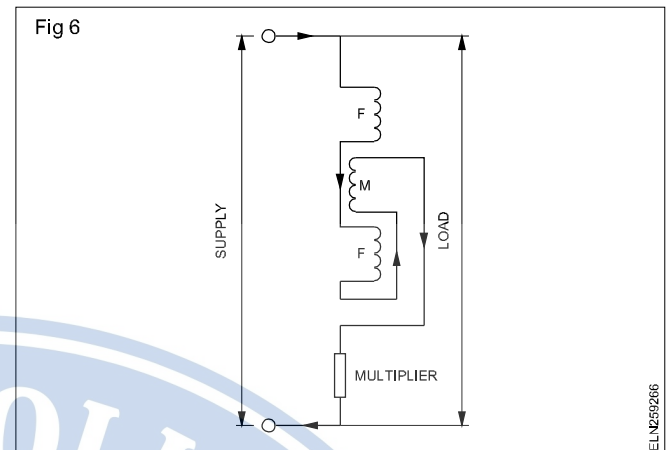

**Advantage:** This instrument can be used both AC and DC

Skill India  
कौशल भारत - कुशल भारत

Fig 1



TYPICAL DIGITAL AMMETER

#### Standards :

Digital ammeters must have a certain standards and specifications to ensure proper design and functionality refer IEC 600 51 - 2.

## Digital Volt Meter (DVM)

**Objectives:** At the end of this lesson you shall be able to

- distinguish between analogue and digital voltmeter
- list out the advantage of DVM
- explain the working principle of DVM.

### Digital Volt Meter (DVM) :

The Digital Volt Meter(DVM) is an electrical measuring instrument which is used to measure line potential difference (P.D) between two points. The voltage to be measured may be AC or DC.

Digital voltmeters display the value of AC or DC voltage being measured directly as discrete numerical instead of a pointer deflection on a continuous scale as in analog instruments.

### Advantages of Digital Voltmeters:

- Read out of DVMs is easy as it eliminates observational errors in measurement
- Parallax error is eliminated
- Reading can be taken very fast
- Output can be fed to memory devices for storage and future computations
- More versatile and accurate
- Compact portable and cheap
- Requires low power

### Working Principle of Digital Voltmeter:

The block diagram of a simple digital voltmeter is shown in the Fig 1 It consists the following blocks

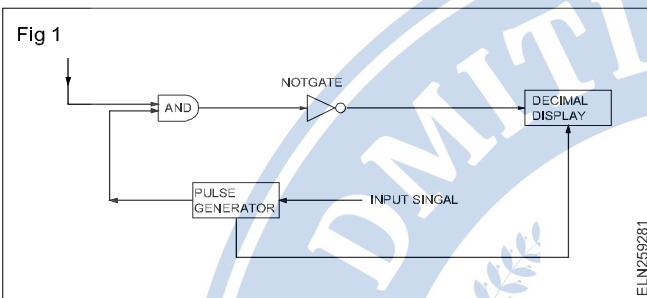

- 1 Input signal
- 2 Pulse generator
- 3 AND gate:
- 4 Decimal Display

### Working (Fig 2)

- Unknown voltage signal is fed to the pulse generator which generates a pulse whose width is proportional to the input signal.
- Output of pulse generator is fed to one leg of the AND gate.

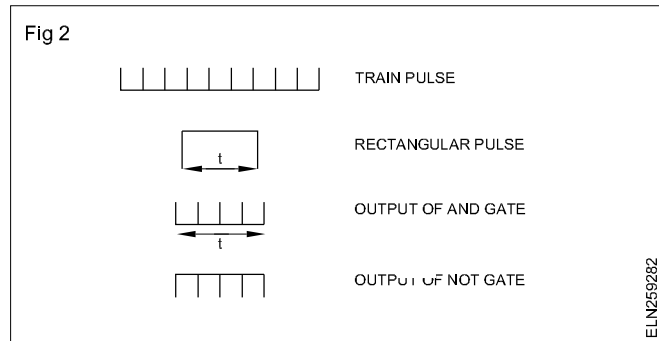

- The input signal to the other leg of the AND gate is a train of pulses.
- Output of AND gate is positive triggered train of duration same as the width of the pulse generated by the pulse generator.
- This positive triggered train is fed to the inverter which converts it into a negative triggered train.
- Output of the inverter is fed to a counter which counts the number of triggers in the duration which is proportional to the input signal i.e. voltage under measurement

This counter can be calibrated to indicate voltage in volts converts an analog signal into a train of pulses, the number is proportional to the input signal. So a digital voltmeter can be made by using any one of the A/D conversion methods (Fig 3)

Now-a-days digital voltmeters are also replaced by digital multi meters due to its multitasking feature.

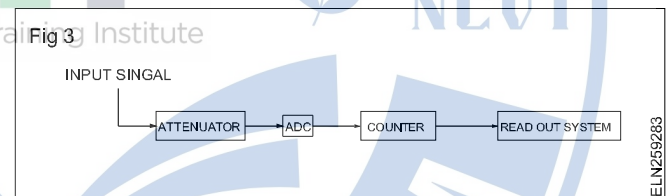

**Wattmeters**

**Objectives:** At the end of this lesson you shall be able to

- state the advantages of measuring power directly
- explain the construction and working of the induction type single phase wattmeter.

Advantages of measuring power supply

Power in a single phase AC circuit can be calculated by using an ammeter, a voltmeter and a power factor meter with the help of the formula

Power in a single phase circuit =  $EI \cos \phi$  watts.

To get an on the spot true power reading, a wattmeter is used. The power dissipated in the circuit can be read directly from the scale of the meter. The wattmeter takes the power factor of the circuit into account and always indicates the true power.

**Types of wattmeters**

There are three types of wattmeters in use as stated below.

- Dynamometer wattmeter
- Induction wattmeter
- Electrostatic wattmeter

Among the three, the electrostatic type is very rarely used. Information given here is for the other two types only.

**Dynamometer type, single phase wattmeter:** This type is commonly used as a wattmeter.

**Dynamometer used as a Wattmeter:** The dynamometer is commonly used as a wattmeter to measure power in both AC and DC circuits and will have uniform scale.

When this instrument is used as a wattmeter, the fixed coils are treated as current coil, and the moving coil is made as pressure coil with necessary multiplier resistance (Fig 1).

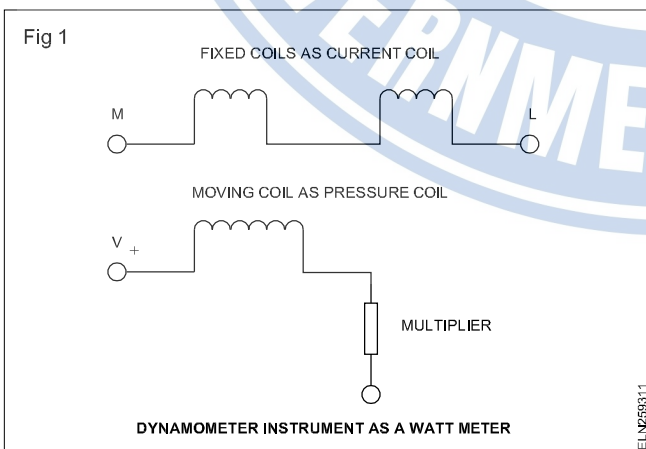

**Advantages**

- This instrument can be used both in AC and DC.

- As this is an air cored instrument, the hysteresis and eddy current losses are eliminated.
- This instrument has better accuracy.
- When used as wattmeter, the scale is uniform.

**Disadvantages**

- It is more expensive than PMMC and moving iron instruments.
- When used as voltmeter or ammeter the scale will not be uniform.
- It has a low torque/weight ratio-as such has low sensitivity.
- Sensitive for overloads and mechanical impact. Hence careful handling is necessary.
- It consumes more power than PMMC meters.

**Induction type single phase wattmeter:** This type of wattmeters could be used only in AC circuits whereas a dynamometer type wattmeter could be used in both AC and DC circuits.

Induction type wattmeters are useful only when the supply voltage and frequency are almost constant.

**Construction:** Induction wattmeters having two different types of magnetic cores (Figs 2a and 2b).

Both the types have one pressure coil magnet and one current coil magnet. The pressure coil carries a current proportional to the voltage whereas the current coil carries the load current.

A thin aluminium disc is mounted on a spindle in between the space of the magnets and its movement is controlled by springs. The spindle carries a weightless pointer at one end.

**Working:** The alternating magnetic fluxes produced by the pressure and current coils cut the aluminium disc and produce eddy currents in the disc. Due to the interaction between the fluxes and the eddy currents a deflecting torque is produced in the disc and the disc tries to move. Control springs attached to the two ends of the spindle control the deflection and the pointer shows the power in watts on a graduated scale.

Shaded rings provided in the pressure coil (shunt) magnet could be adjusted in order to cause the resultant flux in the magnet to lag in phase by exactly 90° behind the applied voltage.

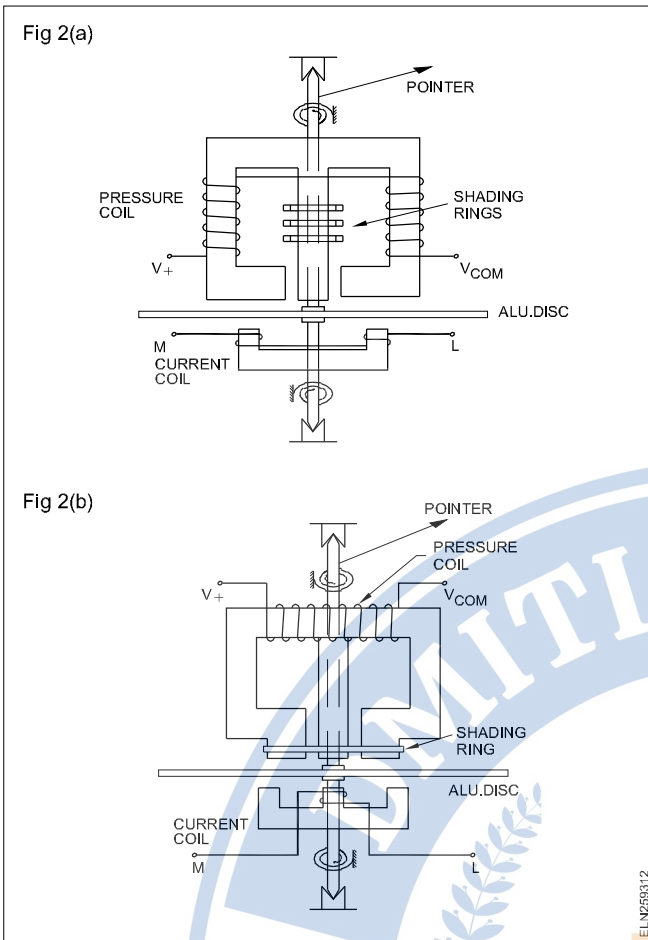

**Method of connecting wattmeter in single phase circuits - pressure coil connection to reduce erroneous measurement.**

There are two ways of connecting the pressure coil of the wattmeter (Fig 3).

Both the methods shown in Figs 3a & b need correction in power measurement due to the reasons stated below.

In the method of connection shown in Fig 3a, the pressure coil is connected on the 'supply' side of the current coil, and hence, the error in power measurement is due to the fact

that the voltage applied to the voltage coil is higher than that of the load on account of the voltage drop in the current coil. As such the wattmeter measures the load power in addition to the power lost in the current coil.

On the other hand, in the method of connection shown in Fig 3b, the current coil carries the small current taken by the voltage coil, in addition to the load current, thereby introducing errors in power measurement. As such the wattmeter measures the load power in addition to the power lost in the pressure coil.

If the load current is small, the voltage drops in the current coil will be small, so that the method of connection, shown in Fig 3a, introduces a very small error and, hence, preferable.

On the other hand, if the load current is large the power lost in the pressure coil will be negligible when compared to the load power in the method of connection shown in Fig 3b, and, hence, a very small error is introduced resulting in the preference of this connection.

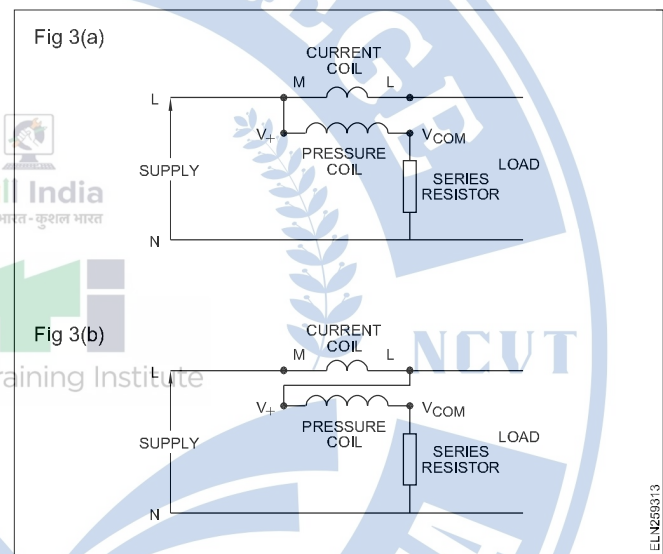

**3-Phase Wattmeter**

- Objectives:** At the end of this lesson you shall be able to
- describe the various types of 3-phase wattmeters, their connections
  - state how to connect different types of 3 phase watt meter.

In single-phase wattmeters there will be one set of pressure and current coils driving a single aluminium disc, whereas in 2-element, three phase wattmeters there will be two sets of pressure and current coils driving a single aluminium disc (Fig 1a) or driving two aluminium discs mounted on the same shaft (Fig 1b) thereby providing a torque proportional to the 3-phase power.

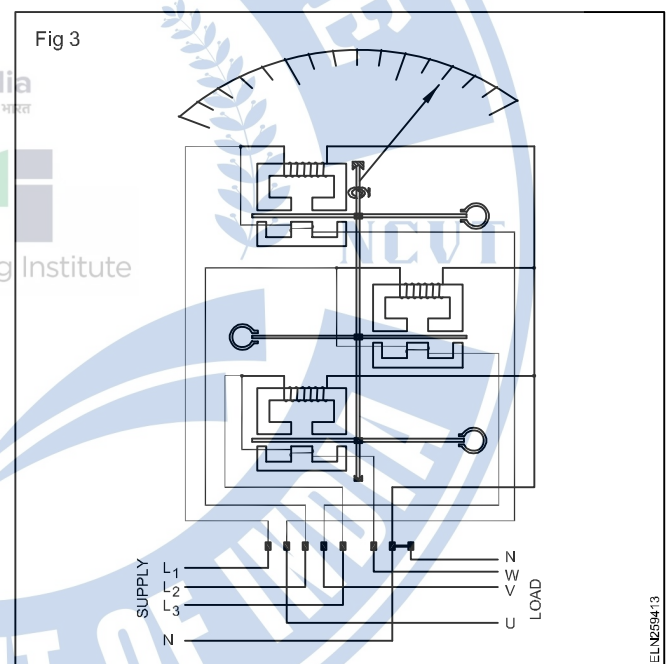
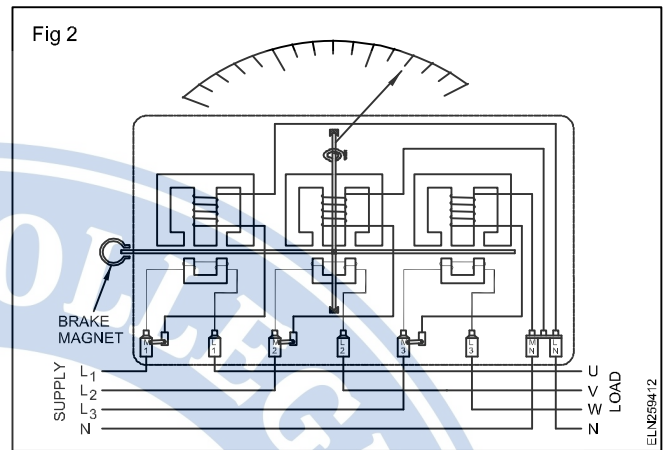
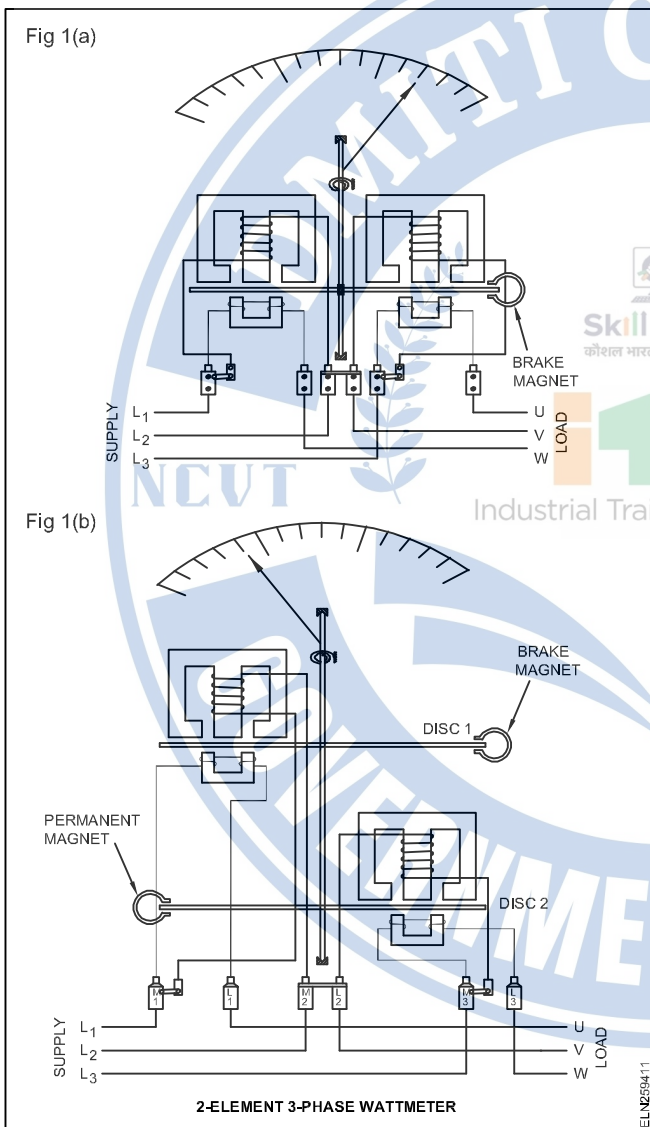

The principle and working of an induction type wattmeter are similar to the induction type energy meter. The only difference in construction between the energy meter and wattmeter is that the spindle of the wattmeter is spring-controlled, has a pointer but no train of gears.

However to summarise what has been learnt earlier the following table 1 is provided with connection diagram of 3-phase wattmeter Fig 4, Fig 5 & Fig 6

On the other hand a 3-element, 3-phase wattmeter will have three sets of pressure and current coils kept at 120° to each other but driving a single aluminium disc (Fig 2) or alternatively 3 sets of pressure and current coils driving three discs one over the other but mounted on the same single spindle (Fig 3).

Table 1

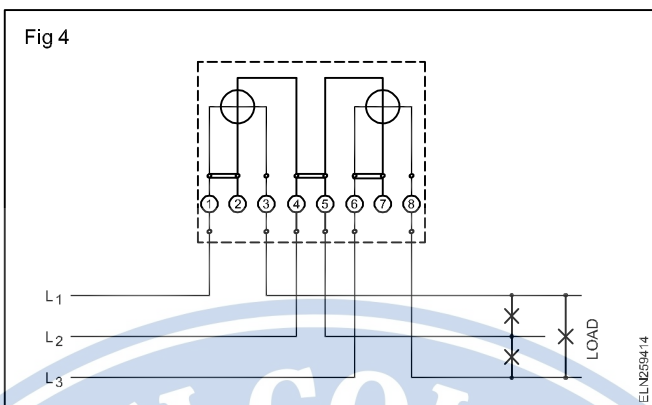
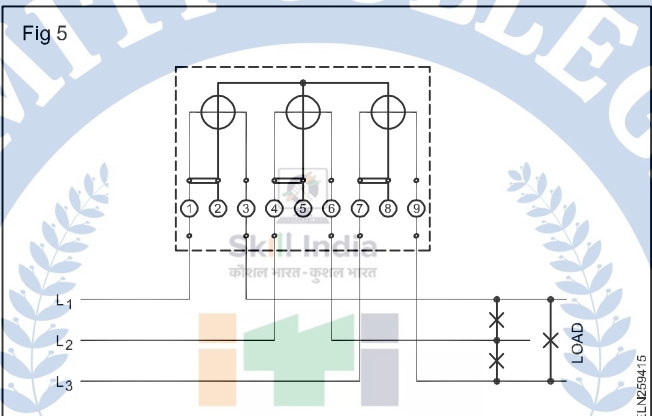
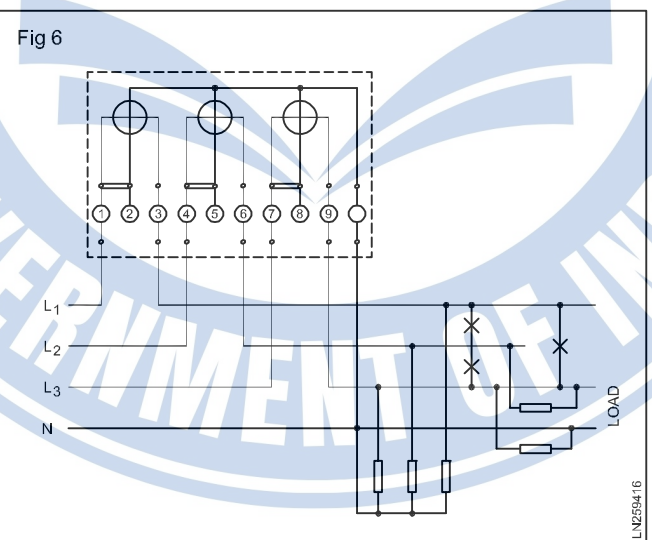
SI.No.	Types of 3-phase wattmeter	Circuit diagram	Application
1	2-element 3-wire type	<p>Fig 4</p>  <p>ELN259414</p>	Balanced and unbalanced loads.
2	3-element 3-wire type	<p>Fig 5</p>  <p>ELN259415</p>	Balanced loads.
3	3-element 4-wire type	<p>Fig 6</p>  <p>ELN259416</p>	Un balanced loads.

# Digital Wattmeter

**Objectives:** At the end of this lesson you shall be able to

- describe the block diagram.

## Digital wattmeter

The wattmeter is an instrument for measuring the electric power in watts of any given circuit. Electromagnetic wattmeters are used for measurement of utility frequency and audio frequency and audio frequency power; other types are required for radio frequency.

Digital wattmeters measure current and voltage electronically thousands of times a second, multiplying the results in a computer microcontroller chip to determine watts. The computer can also perform statistics such as peak, average, low watts consumed. They can monitor the power line for voltage surges and outages. Digital electronic wattmeter, have become popular for conveniently measuring power consumption in household appliances with saving energy and money.

Fig 1 shows the block diagram of digital wattmeter.

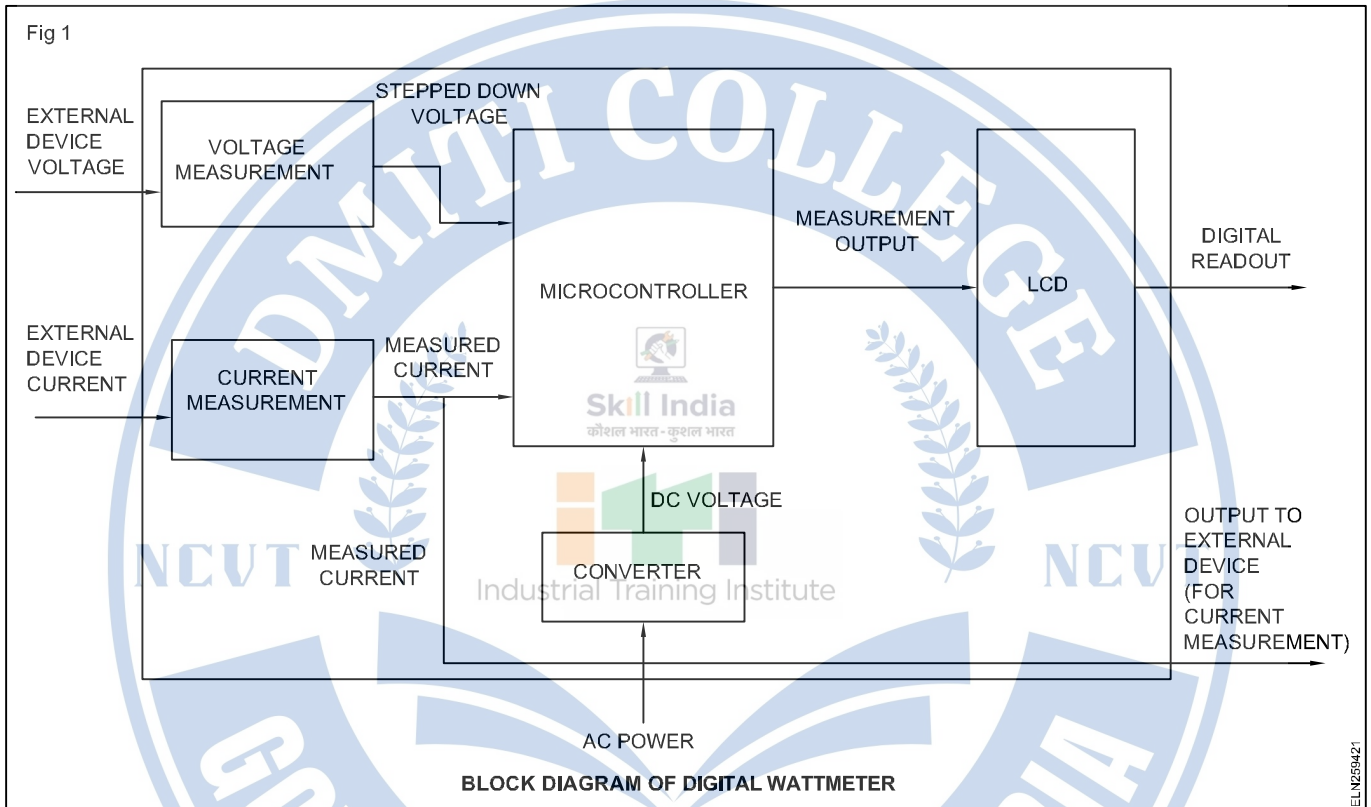

## Energy meter (analog)

**Objectives:** At the end of this lesson you shall be able to

- describe the construction and working principle of single phase energy meters
- state and explain creeping error in energy meter.

**Necessity of energy meter:** The electrical energy supplied by the Electricity board should be billed, based on the actual amount of energy consumed. We need a device to measure the energy supplied to a consumer. Electrical energy is measured in kilowatt hours in practice. The meter used for this is an energy meter.

**Principle of a single phase induction type energy meter:** The operation of this meter depends on the induction principle. Two alternating magnetic fields produced by two coils induce current in a disc and produce a torque to rotate it (disc). One coil (potential coil) carries current proportional to the voltage of the supply and the other (current coil) carries the load current. (Fig 1) Torque is proportional to the power as in wattmeter.

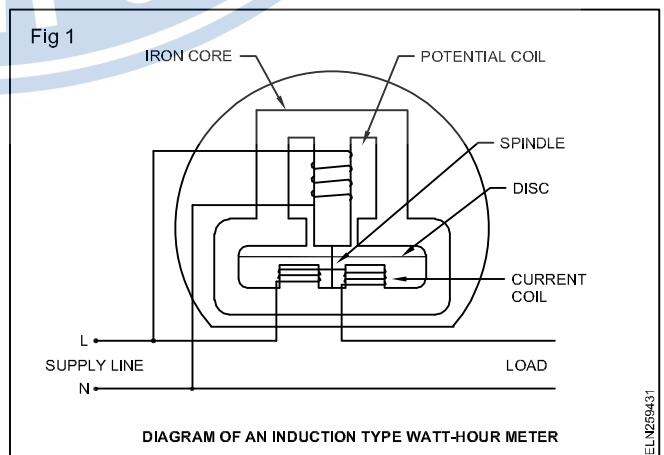

The watt-hour meter must take both power and time into consideration. The instantaneous speed is proportional to the power passing through it.

The total number of revolutions in a given time is proportional to the total energy that passes through the meter during that period of time.

**Parts and functions of an energy meter:** The parts of the induction type single phase energy meter are (Fig 1).

**Iron core:** It is specially shaped to direct the magnetic flux in the desired path. It directs the magnetic lines of force, reduces leakage flux and also reduces magnetic reluctance.

**Potential coil (voltage coil):** The potential coil is connected across the load and is wound with many turns of fine wire. It induces eddy current in the aluminium disc.

**Current coil:** The current coils, connected in series with load, are wound with a few turns of thick wire, since they must carry the full load current.

**Disc:** The disc is the rotating element in the meter, and is mounted on a vertical spindle which has a worm gear at one end. The disc is made of aluminium and is positioned in the air gap between the potential and current coil magnets.

**Spindle:** The spindle ends have hardened steel pivots. The pivot is supported by a jewel bearing. There is a worm gear at one end of the spindle. As the gear turns the dials, they indicate the amount of energy passing through the meter.

**Permanent magnet/brake magnet:** The permanent magnet restrains the aluminium disc from racing at a high speed. It produces an opposing torque that acts against the turning torque of the aluminium disc.

**Functioning of energy meters:** The rotation of the aluminium disc (Fig 2) is accomplished by an electromagnet, which consists of a potential coil and current coils. The potential coil is connected across the load. It induces an eddy current in the aluminium disc. The eddy current produces a magnetic field which reacts with the magnetic field produced by the current coils to produce a driving torque on the disc.

The speed of rotation of the aluminium disc is proportional to the product of the amperes (in the current coils) and the volts (across the potential coil). The total electrical energy that is consumed by the load is proportional to the number of revolutions made by the disc during a given period of time.

A small copper ring (shading ring) or coil (shading coil) is placed in the air gap under the potential coil, to produce a forward torque, large enough to counteract any friction produced by the rotating aluminium disc.

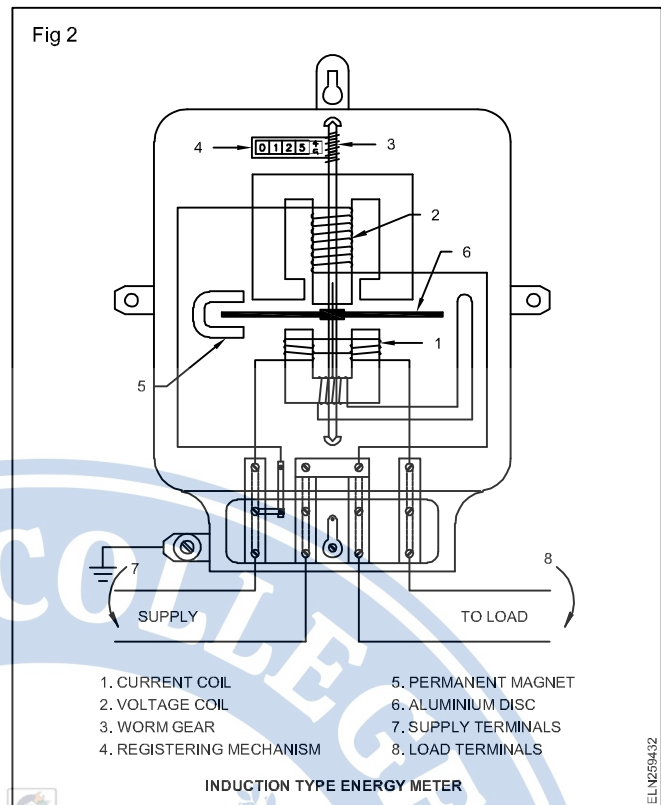

This counter torque is produced when the aluminium disc rotates in the magnetic field established by the permanent magnet. The eddy currents, in turn, produce a magnetic field that reacts with the field of the permanent magnet, causing a restraining action that is proportional to the speed of the disc

**Creeping error and adjustment:** In some meters the disc rotates continuously even when there is no current flow through the current coil i.e. when only the pressure coil is energised. This is called creeping. The major cause for creeping is over-compensation for friction. The other causes for creeping are excessive voltage across the pressure coil, vibrations and stray magnetic fields.

In order to prevent creeping, two diametrically opposite holes are drilled in the disc (Fig 3). The disc will come to rest with one of the holes under the edge of a pole of the potential coil magnet, the rotation being thus limited to a maximum of half a revolution.

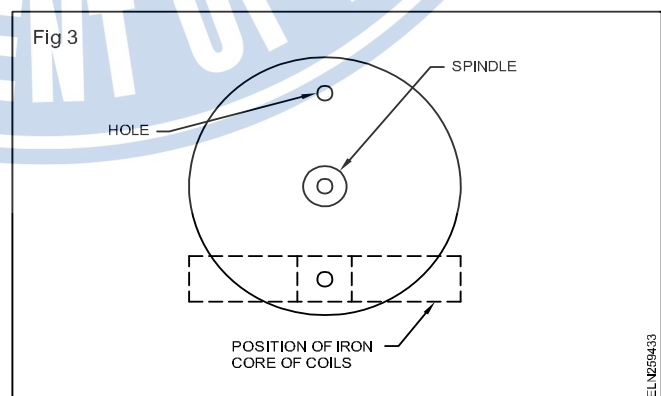

## Digital Energy meters

**Objectives:** At the end of this lesson you shall be able to

- describe the functional operation of digital type energymeter from block diagram.

### Electronic (Digital energy meter)

This meters measure the energy using highly integrated components and it digitizes the instantaneous voltage and current in a high-resolution sigma-delta analogue to digital converter (ADC), gives the instantaneous power in watts.

Integration over time gives energy used, measured in kilo-Watt hour. The block diagram for a digital meter is shown in Fig 1. The two sensors, voltage and current sensors are employed.

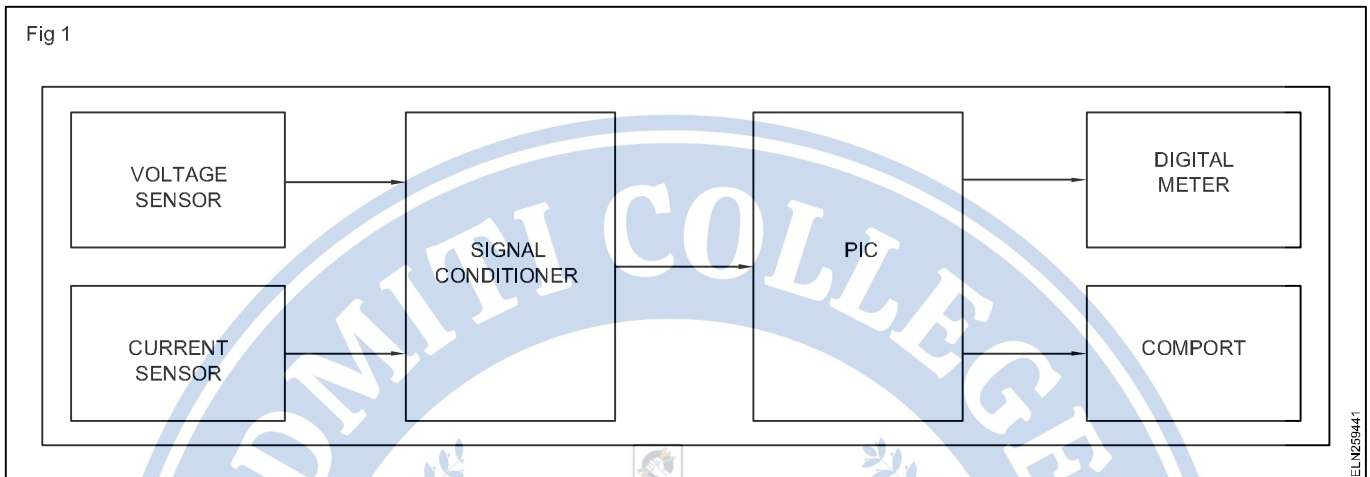

The voltage sensor built around a step down element and potential divider network sensors both the phase voltage and load voltage.

The second sensor is a current sensor, which senses the current drawn by the load at any point in time .

It's inbuilt around a current transformer and other active devices (voltage comparator), which converts the sensed current to voltage for processing. The output from both sensors is then fed into a signal (voltage) conditioner which ensures matched voltage (or) signal level to the control circuit containing multiplexer. It enables sequential switching of both signal to the analogue input of the Peripheral Interface Controller (PIC).

The control circuit centred on a PIC integrated circuit. It contains ten bit analogue to digital converter (ADC), flexible to program and good for peripheral interfacing.

The ADC converts the analogue signals to its digital equivalent, both signals from the voltage and current sensors are then multiplied by the means of embedded software in the PIC.

The error correction is taken as the offset correction by determining the value of the input quality in the short circuited input and storing this value in the memory for use as the correction value device calibration.

The PIC is programmed in 'C' language. It stimulates to use the received data to calculate power consumption per hour, as well as the expected charges. These are displayed on the liquid crystal display (LCD) attached to the circuit.

Fig 2 shows the image of a digital energy meter.

### Advantages

DIGITAL electronic meters are much more accurate than electromechanical meters. There are no moving parts and, hence, mechanical defects like friction are absent



## 3-phase energy meter

**Objectives:** At the end of this lesson you shall be able to

- list the various types of 3-phase energy meters
- describe the construction and working of a 3-phase 3-wire induction type energy meter
- describe the construction and working of a 3-phase 4-wire induction type energy meter
- state the application of a 3-phase 3-wire and 3-phase 4-wire energy meter.

**3-phase energy meters:** Even though different types of energy meters are available, the induction type energy meter is most commonly used because it is simple in construction, less in cost and requires less maintenance. The function of a 3-phase energy meter is similar to that of a single phase energy meter.

### Types of 3-phase energy meters

There are two types of 3-phase energy meters mainly.

- Three phase 3-wire energy meters (3-phase 2- element energy meter)
- Three phase 4-wire energy meters (3-phase 3- element energy meter)

**Two element 3-phase energy meters:** This energy meter works on the principle of measurement of power by the two wattmeter method. Two elements of a current coil and two elements of a potential coil are used in this energy meter. These assemblies can be arranged on the different sectors in a horizontal position (Fig 1) with a single aluminium disc which rotates between the poles of a single braking magnet.

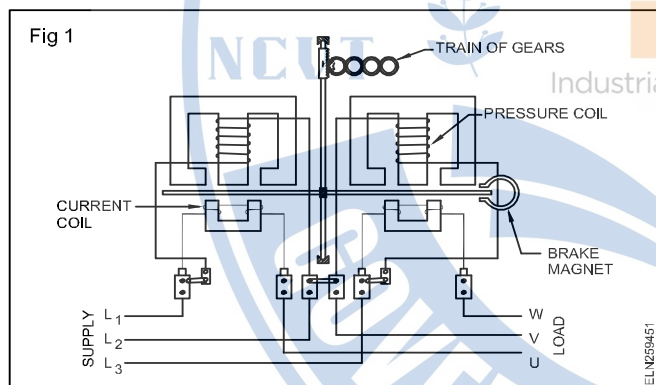

The two elements can also have individual driving discs on a common spindle. In this case they will have individual braking magnets (Fig 2). The second type usually preferred by the manufacturers due to the construction simplicity.

In both the cases the driving torque produced by individual elements are summed up. The recording mechanism which is attached to the train of gears i.e., cyclometer or counter type dial shows the sum of the energies that has passed through the elements. The two element energy meter is only suitable for a 3-phase 3-wire system but can be used for both balanced and unbalanced loads.

**3-element 3-phase energy meter:** This works on the same principle as that of the 3 wattmeter method of power measurement with a 3-phase load. Here 3 units, each with a current coil and a potential coil, are used. The potential coils of the 3 elements are connected in star to the supply lines with their common point connected to the neutral line of power supply.

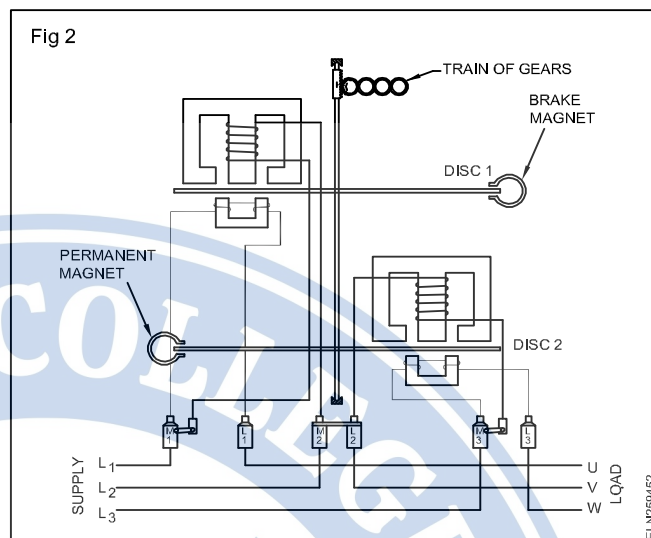

The current coils are connected in series to the individual lines. As is the case with the two element energy meter, these three elements can be arranged in the different sectors of a common single aluminium disc which serves as a rotating part connected to driving dial (Fig 3).

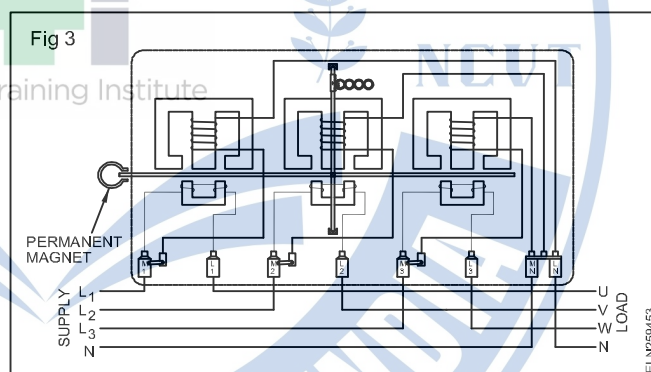

The three elements can also have a common spindle with three individual discs and braking magnets (Fig 4). Here also the 2nd type is usually preferred by manufacturers due to the easiness in construction. The driving torque produced by the three individual elements are summed up and the recording mechanism shows the sum of energies that has passed through the individual elements. This energy meter is suitable for the 3-phase 4-wire system.

**Application of 3-phase energy meter:** A two element 3-phase energy meter is used with three phase loads in which a neutral is not used such as for an industry or irrigation pumpset motors etc. having three phase loads only or with an 11kV 3-phase 3-wire supply to an industry.

A 3-phase 4-wire element energy meter is used with three phase load in which balanced or unbalanced loads are connected with individual phases and neutral such as for a large domestic consumer or for an industry having lighting loads also.

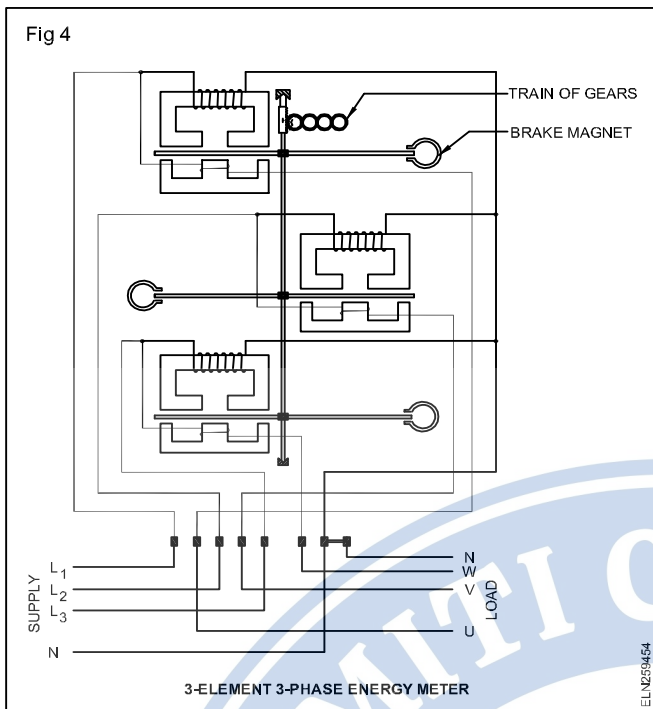

## Errors and correction in energy meter measurement

**Objectives:** At the end of this lesson you shall be able to

- explain the errors caused by the driving system and the braking system in energy meters
- explain the different adjustments provided for correcting the errors in energy meters.

### Errors caused by the driving system

**Incorrect magnitude of fluxes:** This may be due to abnormal values of current or voltage. The shunt magnet flux may be in error due to changes in resistance of coil or due to abnormal frequencies.

**Incorrect phase angles:** There may not be a proper relationship between the various phasors. This may be due to improper lag adjustment, abnormal frequencies, change in resistance with temperature etc.

**Lack of symmetry in magnetic circuit:** If the magnetic circuit is not symmetrical, a driving torque is produced which makes the meter creep.

### Error caused by the braking system

They are:

- changes in the strength of the brake magnet
- changes in the disc resistance
- self-braking effect of series magnet flux
- abnormal friction of the moving parts.

Adjustments are provided for correcting the errors in the energy meters so that they read correctly and their errors are within acceptable limits.

**Preliminary light load adjustment:** The rated voltage is applied to the potential coil with no current through the current coil and the light load device is adjusted until the disc just fails to start. The electromagnet is slightly adjusted to make the holes in the disc to take a position in between the poles of the electromagnets.

**Full load unity power factor adjustment:** The pressure coil is connected across the rated supply voltage and the rated full load current at unity power factor is passed through the current coils. The position of the brake magnet is adjusted to vary the braking torque so that the meter revolves at the correct speed within the required limits of error.

**LAG adjustments (Low power factor adjustments):** The pressure coil is connected across the rated supply voltage and the rated full load current is passed through the current coil at 0.5 P.F. lagging. The lag device is adjusted till the meter runs at the correct speed.

**Rated supply voltage:** By adjusting the rated supply voltage, with the rated full load current and unity power factor, the speed of the meter is checked and the full load unity power factor and low power factor adjustments are repeated until the desired accuracy limits are reached for both the conditions.

**Light load adjustment:** The rated supply voltage is applied across the pressure coil and a very low current (about 5% of full load current) is passed through the meter at unity power factor. Light load adjustment is done so that the meter runs at the correct speed.

**Full load unity power factor:** Light load adjustments are again done until the speed is correct for both loads i.e. full load as well as light loads.

**Creep adjustment:** As a final check on the light load adjustment, the pressure coil is excited by 110 percent of the rated voltage with zero load current. If the light load adjustment is correct, the meter should not creep under these conditions.

# Multimeters

**Objectives:** At the end of this lesson you shall be able to

- explain the construction of multimeter
- explain the working principle of analog multimeter
- explain the method of measuring direct / alternating voltages and current with a multimeter
- explain the method of measuring resistance by a multimeter
- explain the precautions to be observed while measuring voltage, current and resistance in the circuit.

A single instrument used for measuring current voltage and resistance is known as a multimeter. It is a portable, multi range instrument.

It has a full scale deflection accuracy of  $\pm 1.5\%$ . The lowest sensitivity of multimeters for AC voltage range is 5 K ohms/volts and for the DC voltage range it is 20 K ohms/volts. The lowest range of DC is more sensitive than the other ranges.

Figs 1 show typical multimeters.



## Construction of a multimeter

A multimeter uses a single meter movement with a scale calibrated in volts, ohms and milliamperes. The necessary multiplier resistors and shunt resistors are all contained within the case. Front panel selector switches are provided to select a particular meter function and a particular range for that function.

On some multimeters, two switches are used, one to select a function, and the other the range. Some multimeters do not have switches for this purpose; instead, they have separate jacks for each function and range.

Batteries/cells fixed inside the meter case provide the power supply for the resistance measurement.

The meter movement is that of the moving coil system as used in DC ammeters and voltmeters.

Rectifiers are provided inside the meter to convert AC to DC in the AC measurement circuit.

## Parts of a multimeter

A standard multimeter consists of the main parts and controls (Fig 2).

## Controls

The meter is set to measure the current, voltage (AC and DC) or resistance by means of the FUNCTION switch. In the example given in Fig 3 the switch is set to mA, AC.

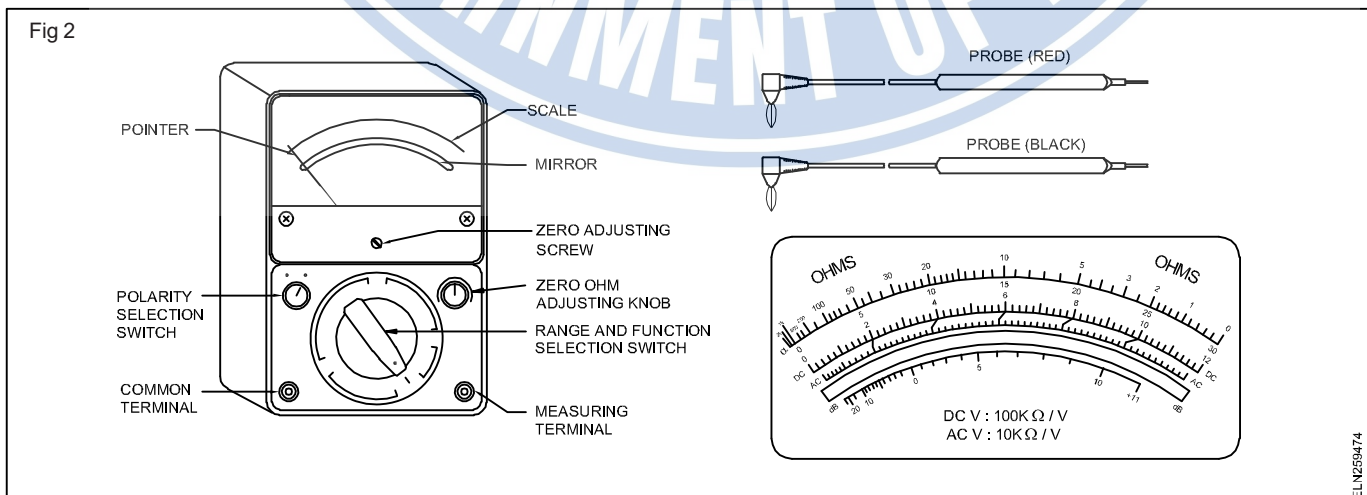

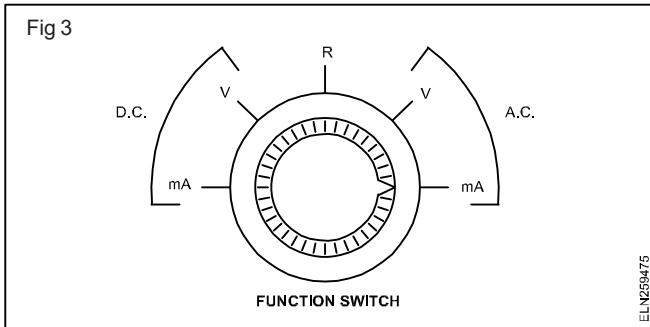

The meter is set to the required current, voltage or resistance range - by means of the RANGE switch. In Fig 4, the switch is set to 2.5 volts or mA, depending on the setting of the FUNCTION switch.

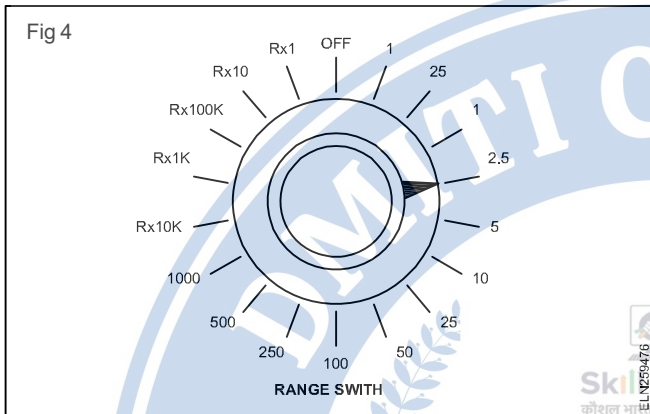

### Scale of multimeter

Separate scales are provided for:

- resistance
- voltage and current.(Fig 5)

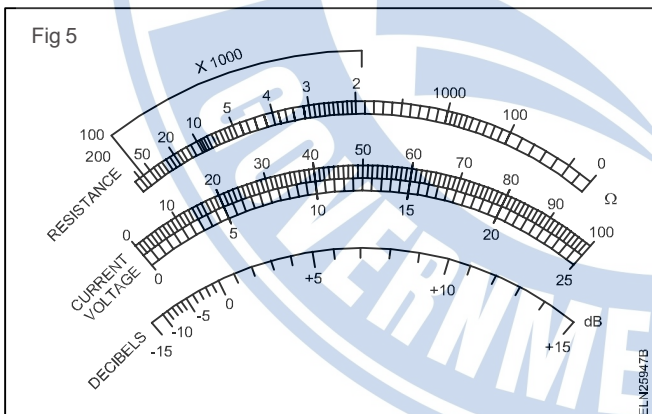

The scale of current and voltage is uniformly graduated.

The scale of the ohmmeter is non-linear.

The scale is usually 'backward', with zero at the right.

### Principle of working

A circuitry when working as an ammeter.(Fig 6)

Shunt resistors across the meter movement bypass current in excess of 0.05 mA at fsd. A suitable value of shunt resistor is selected through the range switch for the required range of current measurement.

A circuitry when working as a voltmeter. (Fig 7)

The voltage drop across the meter coil is dependent on the current and the coil resistance. To indicate voltages greater than 50 mV at fsd as per the circuit, multiplier resistances of different values are connected in series with the meter movement through the range switch for the required range of measurement.

A circuitry when working as an ohmmeter. (Fig 8)

To measure resistance, the leads are connected across the external resistor to be measured (Fig 8). This connection completes the circuit, allowing the internal battery to produce current through the meter coil, causing deflection of the pointer, proportional to the value of the external resistance being measured.

### Zero adjustment

When the ohmmeter leads are open, the pointer is at full left scale, indicating infinite ( $\infty$ ) resistance (open circuit). When the leads are shorted, the pointer is at full right scale, indicating zero resistance.

The purpose of the variable resistor is to adjust the current so that the pointer is at exactly zero when the leads are shorted. It is used to compensate for changes in the internal battery voltage due to aging.

### Multiple range

Shunt (parallel) resistors are used to provide multiple ranges so that the meter can measure resistance values from very small to very large ones. The reading on the ohmmeter scale is multiplied by the factor indicated by the range setting.

**Remember, an ohmmeter must not be connected to a circuit when the circuit's power is on. Always turn the power off before connecting the ohmmeter.**

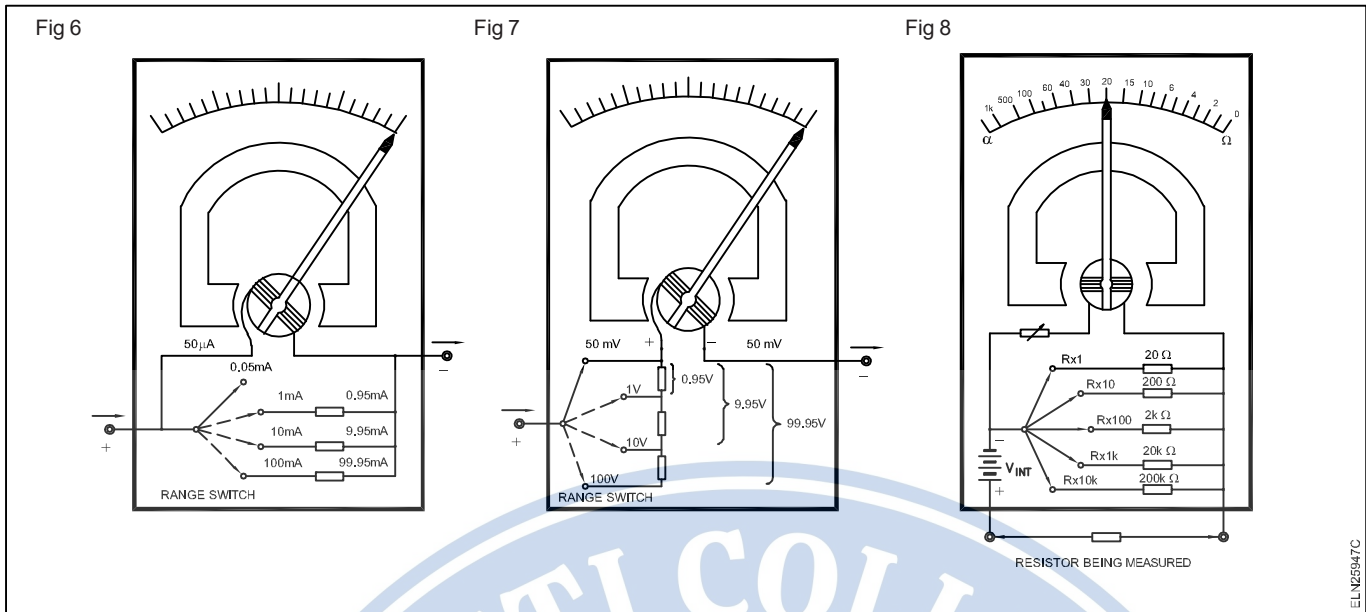

## Digital multimeters

**Objectives:** At the end of this lesson you shall be able to

- explain the method of measurement of voltage by using digital multimeter
- list and explain the types of digital multimeter
- state the application of digital multimeters.

### Digital Multimeter

In a digital multimeter the meter movement is replaced by a digital read out (Fig 1 and 2). This readout is similar to that used in electronic calculators. The internal circuitry of the digital multimeter is made up of digital, integrated circuits. Like the analog-type multimeter, the digital multimeter has a front panel switching arrangement.

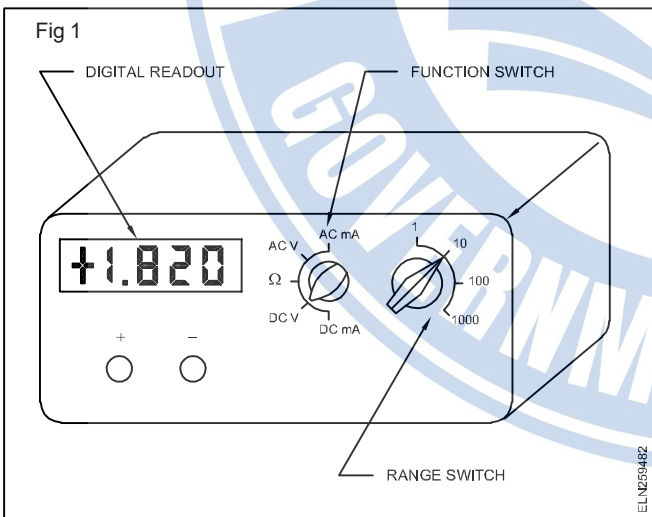

The quantity measured is displayed in the form of a four digit number with a properly placed decimal point. When DC quantities are measured the polarity is identified by '+ve' or '-ve' sign displayed to the left of the number indicating the probes are connected correctly by +ve sign and probes are reversely connected by -ve sign.

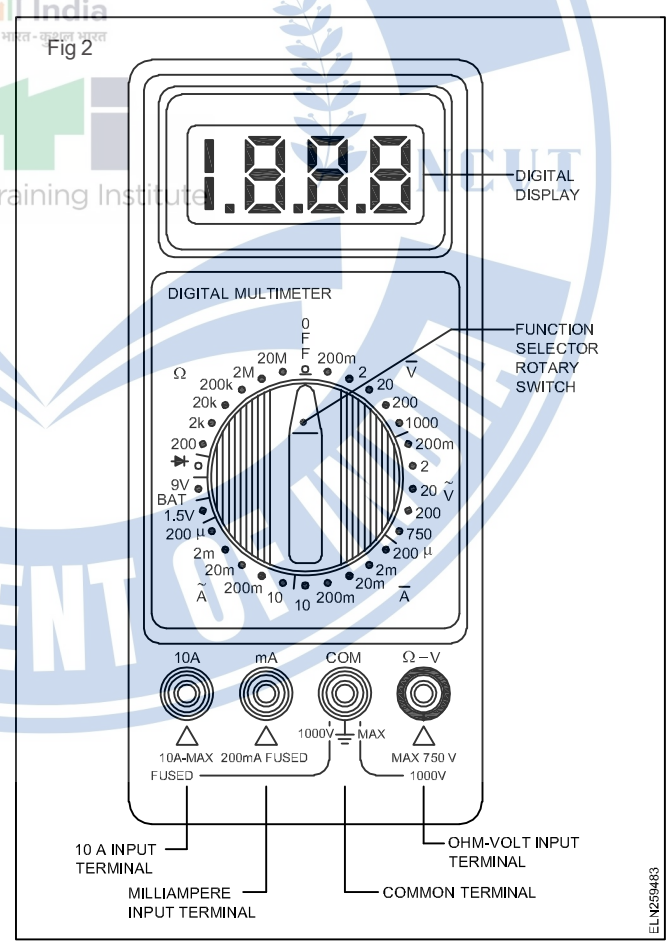

**DMM functions:** The basic functions found on most DMMs are the same as those on analogue multimeters. That is it can measure:-

- ohms
- DC voltage and current
- AC voltage and current

Some DMMs provide special functions such as transistor or diode test, power measurement, and decibel measurement for audio amplifier tests.

**DMM displays:** DMMs are available with either LCD (liquid-crystal display) or LED (light-emitting diode) read-outs. The LCD is the most commonly used read-out in battery-powered instruments due to the fact that it draws very small amount of current.

A typical battery-powered DMM with an LCD read-out operates on a 9V battery that will last from a few hundred hours to 2000 hours and more. The disadvantages of LCD read-outs are that (a) they are difficult or impossible to see in poor light conditions, and (b) they are relatively slow response to measurement changes.

LEDs, on the other hand, can be seen in the dark, and respond quickly to changes in measured values. LED displays require much more current than LCDs, and, therefore, battery life is shortened when they are used in portable equipment.

Both LCD and LED-DMM displays are in a seven segment format (Fig 3).



**Multimeter: Safety precautions:** The following safety precautions should always be taken.

- Never use the ohmmeter section on a live circuit.
- Never connect the ammeter section in parallel with a voltage source.
- Never overload the ammeter or voltmeter sections by attempting to measure currents or voltages far in excess of the range switch setting.
- Check the meter test leads for frayed or broken insulation before working with them. If damaged insulation is found the test leads should be replaced.
- Avoid touching the bare metal clips or tips of the test probes.
- Whenever possible, remove the supply before connecting the meter test leads into the circuit.

**Applications of Digital multimeter:** A multimeter is used for testing and fault finding in electrical/electronic circuits, electrical appliances and machines. A multimeter is a portable handy instrument used for

- checking continuity of circuit, appliances and devices.
- measuring/checking the supply presence at the source
- for testing components like capacitors, diodes, and transistors for checking their condition.
- measuring the current drawn by the circuit.
- measuring resistance of the electrical appliances and devices.

**Note:** Some meters have provision also for temperature measurement with suitable sensing probes.

## Frequency meter

**Objectives:** At the end of this lesson you shall be able to

- state the types of frequency meters
- describe the principle, construction and working of a mechanical resonance (vibrating reed) type frequency meter.

The following types of frequency meters are used for measuring power frequencies.

- Mechanical resonance type
- Electrical resonance type
- Electro-dynamic type
- Electro-dynamometer type
- Weston type
- Ratiometer type
- Saturable core type

The explanation given here is for mechanical resonance type frequency meter only as indicated below.

The trainees are advised to refer to books on electrical measuring instruments for learning about the other types of frequency meters.

### Mechanical resonance type frequency meter (vibration reed type)

**Principle:** The vibration reed type frequency meter shown in Fig 1 works on the principle of natural frequency. Every object in the world has its natural frequency, depending upon its weight and dimensions. When an object is kept in a vibrating medium, it starts vibrating, if the frequency of the medium attains the natural frequency of the object.

If the vibrations are not controlled, the object may even get totally destroyed. A good example of this phenomenon is

the shattering of window glass panes due to the vibration caused by low flying aircraft.

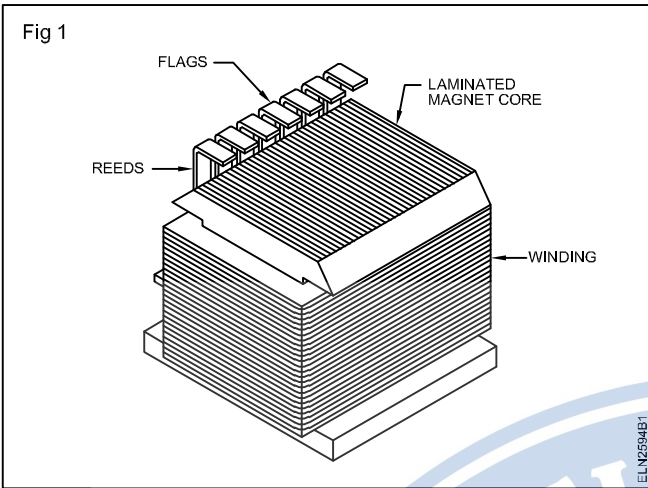

**Construction:** Mechanical resonance type frequency meters consist of an electromagnet and a set of metallic reeds arranged in front of the electromagnet. The frequency meter is connected across the supply like a voltmeter, taking care about the voltage rating (Fig 2).

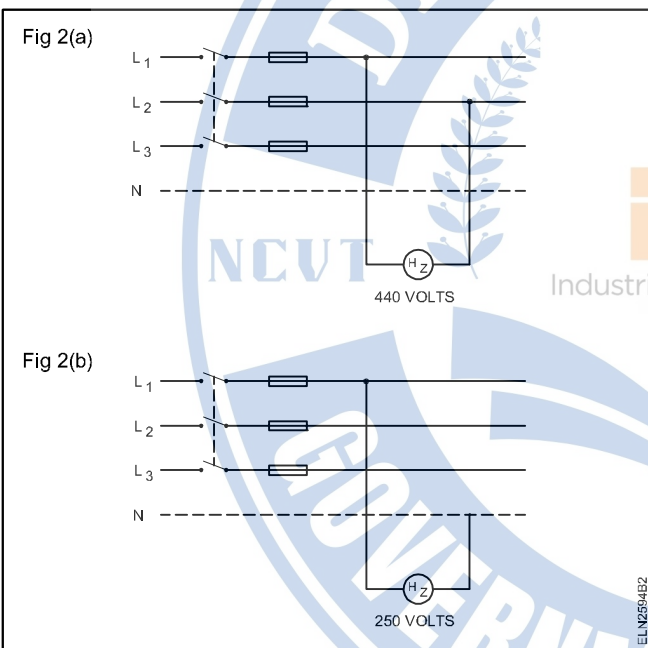
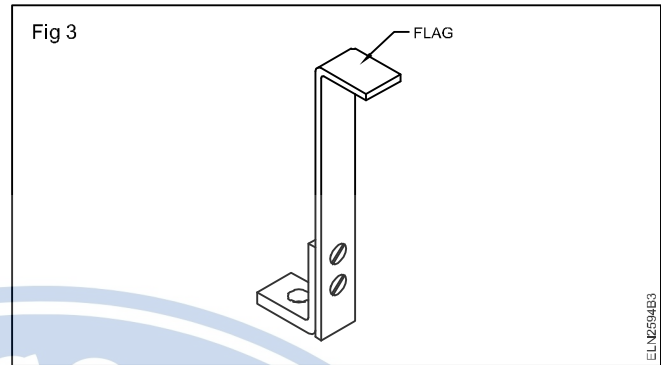

Fig 3 shows the shape of the reed and these reeds are of about 4mm wide and 0.5 mm thick. One end of the reed is fitted on a base, and the other overhanging end carries a white painted surface as the indicator and sometimes referred to as flag.

The reeds are arranged in a row and the natural frequency of the reeds differs by 1/2 cycle. This 1/2 cycle difference

is possible between the reeds due to the difference in the weights of the reeds. The reeds are arranged in an ascending order (Fig 4a), and generally the natural frequency of the centre reed is the same as that of the supply frequency (50Hz).



**Working:** When the frequency meter is connected to the supply, the electromagnet produces a magnetic field which alternates at the rate of the supply frequency. The reed, which has its natural frequency coincident with that of the alternating magnetic field, vibrates more than the adjacent reeds Fig 4(b).

The flag of this vibrating reed makes it possible to note the frequency of the supply from the scale marking of the frequency meter. Though the other reeds also vibrate, Fig 4(b), their magnitude will be much less than the reed whose natural frequency is exactly in coincidence with the supply frequency.

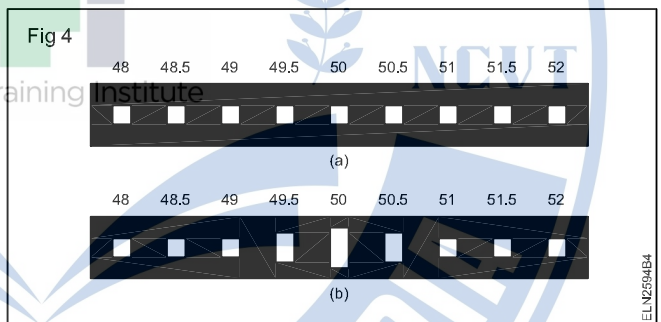

### Advantages and disadvantages

The reed type frequency meter has the following advantages.

The indications are independent of i) the wave form of the applied voltage and ii) magnitude of the applied voltage, provided that the voltage is not too low. At a low voltage the flag indication of the reed will not be reliable.

The disadvantages are the meter cannot read closer than half the cycle frequency difference between adjacent reeds and the accuracy greatly depends upon the proper tuning of the reeds.

# Digital Frequency Meter

**Objectives:** At the end of this lesson you shall be able to

- state the function of digital frequency meter
- describe the block diagram of digital frequency meters.

A frequency counter is a digital instrument that can measure and display the frequency of any periodic waveform. It operates on the principle of gating the unknown input signal into the counter for a predetermined time.

If the unknown input signal were gated into the counter for exactly 1 second, the number of counts allowed into the counter would be the frequency of the input signal. The term gated comes from the fact that an AND or an OR gate is employed for allowing the unknown input signal into the counter to be accumulated. Fig 1

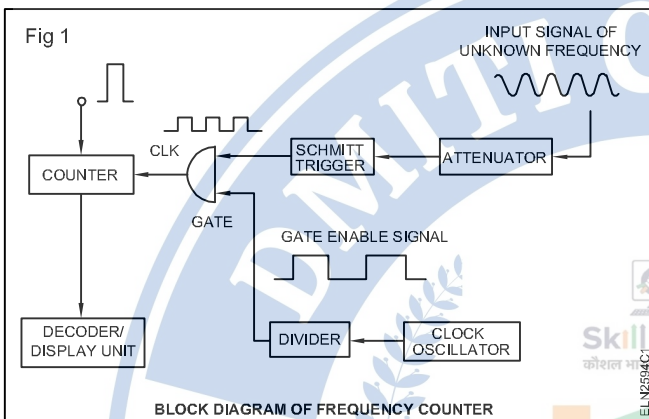

**Description of block diagram:**

The simplified form of block diagram of frequency counter is in Fig 1. It consists of a counter with its associated display/decoder circuitry, clock oscillator, a divider and an AND gate. The counter is usually made up of cascaded Binary Coded Decimal (BCD) counters and the display/decoder unit converts the BCD outputs into a decimal display for easy monitoring.

A GATE ENABLE signal of known time period is generated with a clock oscillator and a divider circuit and is applied to one leg of an AND gate.

The unknown signal is applied to the other leg of the AND gate and acts as the clock for the counter. The counter advances one count for each transition of the unknown signal, and at the end of the known time interval, the

contents of the counter will be equal to the number of periods of the unknown input signal that have occurred during time interval,  $t$ . In other words, the counter contents will be proportional to the frequency of the unknown input signal.

For instance if the gate signal is of a time of exactly 1 second and the unknown input signal is a 600-Hz square wave, at the end of 1 second the counter will count up to 600, which is exactly the frequency of the unknown input signal

The wave form in Fig 2 shows that a clear pulse is applied to the counter at  $t_0$  to set the counter at zero. Prior to  $t_1$ , the GATE ENABLE signal is LOW, and so the output of the AND gate will be LOW and the counter will not be counting. The GATE ENABLE goes HIGH from  $t_1$  to  $t_2$  and during this time interval  $t = (t_2 - t_1)$  the unknown input signal pulses will pass through the AND gate and will be counted by the counter

After  $t_2$ , the AND gate output will be again LOW and the counter will stop counting. Thus, the counter will have counted the number of pulses that occurred during the time interval,  $t$  of the GATE ENABLE SIGNAL, and the resulting contents of the counter are a direct measure of the frequency of the input signal.

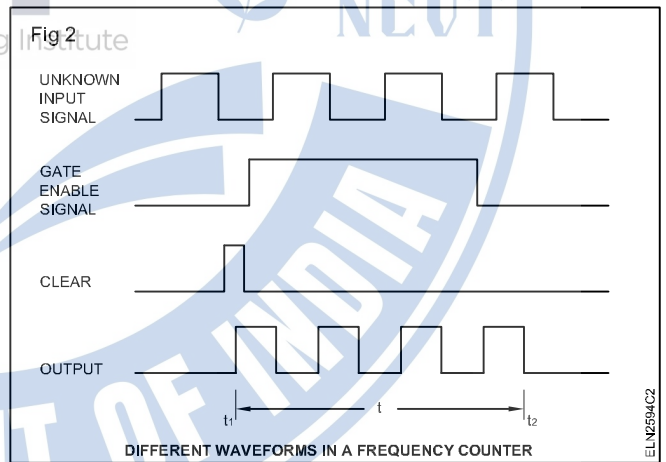

## Power factor meter

**Objectives:** At the end of this lesson you shall be able to

- explain the construction and connection of 3-phase dynamometer type power factor meter
- explain the construction, connection and operation of a 3-phase moving iron type power factor meter
- explain the construction, connection and operation of a single phase moving iron type power factor meter.

**3-phase dynamometer type power factor meter for balanced load:** Fig 1 shows the construction and connections of a 3-phase power factor meter used for balanced loads.

In this meter, the field coils are connected in series with the load along with one phase. The two moving coils are rigidly attached to each other at an angle of  $120^\circ$ . These coils are

connected to two different phases. A resistance is connected in series with each coil.

Phase splitting through reactance is not necessary since the required phase displacement between currents in the two moving coils can be obtained by the supply itself.

Operation of the meter is in the same way as in a single phase meter. However this meter is suitable only for balanced loads.

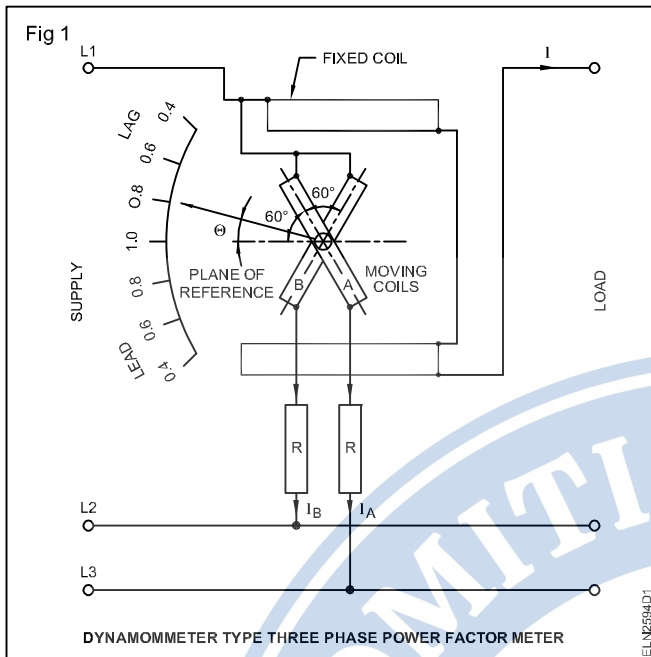

Since the currents in the two moving coils are both affected in the same way by any change in frequency or wave-form, this meter is independent of frequency and wave-form.

**Moving iron power factor meters:** This type of power factor meter is more popular than the dynamometer type due to the following advantages.

- Torque-weight ratio (working forces) is large compared to the dynamometer type meter.
- As all the coils are fixed there is no ligament connection necessary.
- The scale can be extended to 360°.
- This meter is simple and robust in construction.
- Comparatively cheaper in cost.

Fig 2 shows the construction and connection of a moving iron type power factor meter used for balanced loads.

There are three similar coils at  $C_1$ ,  $C_2$  and  $C_3$  placed 120° degrees apart and connected to 3-phase supply directly (Fig 2) or through the secondary of the current transformers. Coil P is placed in the middle of the three coils  $C_1$ ,  $C_2$  and  $C_3$  and connected in series with a resistance across two lines of the supply. Inside the coil P there are two vanes  $V_1$ , and  $V_2$  mounted at the ends of a freely moving spindle but kept at 180° to each other. The spindle also has damping vanes and the pointer.

## Measurement of 3 phase power by single and two wattmeters

**Objectives:** At the end of this lesson you shall be able to

- explain the measurement 3 phase power using single wattmeter
- explain the measurement of 3 phase power using two wattmeters
- calculate the power factor by two wattmeter method power measurement.

**The measurement of power:** The number of wattmeters used to obtain power in a three-phase system depends on

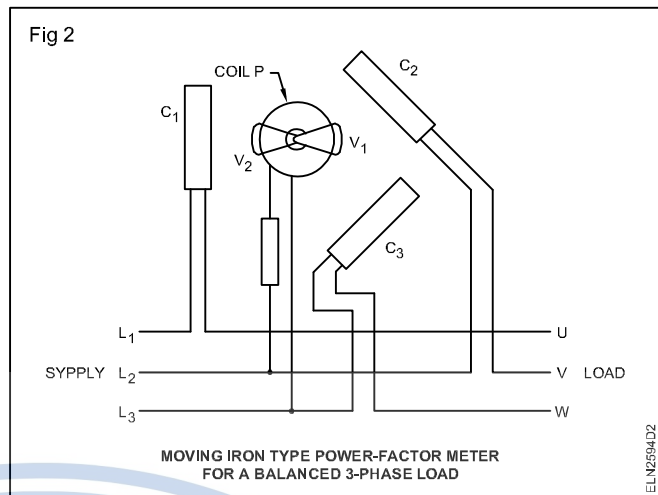

The rotating magnetic field produced by the three coils  $C_1$ ,  $C_2$  and  $C_3$  interacts with the flux produced by the coil P. This causes the moving system to take up an angular position depending upon the phase angle of the current.

**Single phase moving iron power factor meter:** A single phase moving iron power factor meter (Fig 3) uses a phase splitting network comprising of a capacitor, an inductor and a resistor.

**3-phase power factor meters for unbalanced load:** For measurement of power factor in 3-phase unbalanced systems 2-element or 3-element power factor meters with each element with a current coil and pressure coil is used. The pressure coils are (moving coils) similar to that of single phase P.F. meters are mounted one below the other on a single spindle. The pointer shows the resultant power factor.

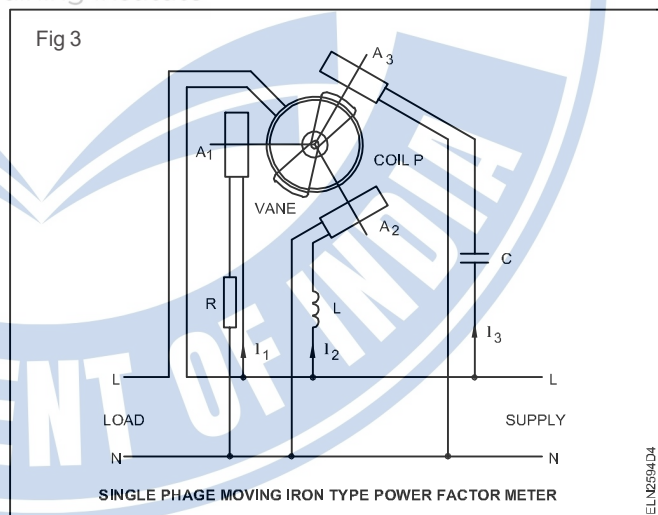

- Measurement of power in a star-connected balanced load with neutral point is possible by a single wattmeter
- Measurement of power in a star or delta-connected, balanced or unbalanced load (with or without neutral) is possible with two wattmeter method

**Single wattmeter method:** Fig 1 shows the circuit diagram to measure the three-phase power of a star-connected, balanced load with the neutral point accessible the current coil of the wattmeter being connected to one line, and the voltage coil between that line and neutral point. The wattmeter reading gives the power per phase. So the total is three times the wattmeter reading.

$$P = 3E_p I_p \cos \phi = 3P = 3W$$

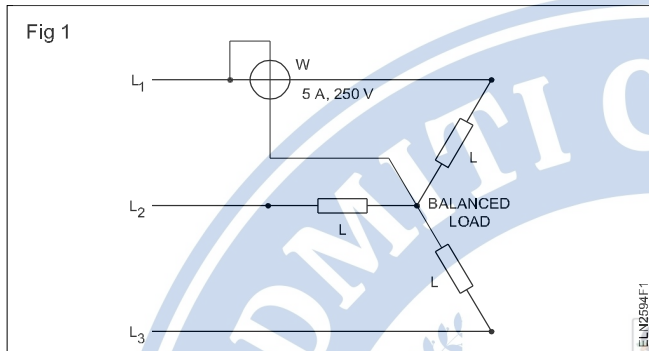

**The two wattmeter method of measuring power**

Power in a three-phase, three-wire system is normally measured by the 'two-wattmeter' method. It may be used with balanced or unbalanced loads, and separate connections to the phases are not required. This method is not, however, used in four-wire systems because current may flow in the fourth wire, if the load is unbalanced and the assumption that  $I_U + I_V + I_W = 0$  will not be valid.

The two wattmeters are connected to the supply system (Fig 2). The current coils of the two wattmeters are connected in two of the lines, and the voltage coils are connected from the same two lines to the third line. The total power is then obtained by adding the two readings:

$$P_T = P_1 + P_2$$

Consider the total instantaneous power in the system  $P_T = P_1 + P_2 + P_3$  where  $P_1, P_2$  and  $P_3$  are the instantaneous values of the power in each of the three phases.

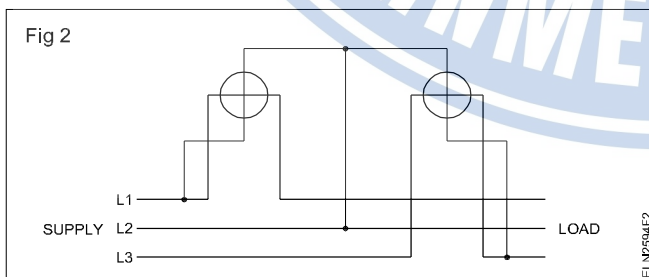

$$P_T = V_{UN} i_U + V_{VN} i_V + V_{WN} i_W$$

Since there is no fourth wire,  $i_U + i_V + i_W = 0$ ;  $i_V = -(i_U + i_W)$ .

$$\begin{aligned} P_T &= V_{UN} i_U - V_{VN} (i_U + i_W) + V_{WN} i_W \\ &= i_U (V_{UN} - V_{VN}) + i_W (V_{WN} - V_{UN}) \\ &= i_U V_{UV} + i_W V_{WV} \end{aligned}$$

Now  $i_U V_{UV}$  is the instantaneous power in the first wattmeter, and  $i_W V_{WV}$  is the instantaneous power in the second wattmeter. Therefore, the total mean power is the sum of the mean powers read by the two wattmeters.

It is possible that with the wattmeters connected correctly, one of them will attempt to read a negative value because of the large phase angle between the voltage and current for that instrument. The current coil or voltage coil must then be reversed and the reading given a negative sign when combined with the other wattmeter readings to obtain the total power.

At unity power factor, the readings of two wattmeter will be equal. Total power = 2 x one wattmeter reading.

When the power factor = 0.5, one of the wattmeter's reading is zero and the other reads total power.

When the power factor is less than 0.5, one of the wattmeters will give negative indication. In order to read the wattmeter, reverse the pressure coil or current coil connection. The wattmeter will then give a positive reading but this must be taken as negative for calculating the total power.

When the power factor is zero, the readings of the two wattmeters are equal but of opposite signs.

**Self-evaluation test**

- 1 Draw a general wiring diagram for the two-wattmeter method of three-phase power measurement.

**Power factor calculation in the two-wattmeter of measuring power**

As you have learnt in the previous lesson, the total power  $P_T = P_1 + P_2$  in the two-wattmeter method of measuring power in a 3-phase, 3-wire system.

From the readings obtained from the two wattmeters, the  $\tan \phi$  can be calculated from the given formula

$$\tan \phi = \frac{\sqrt{3}(P_1 - P_2)}{(P_1 + P_2)} = \frac{\sqrt{3}(W_1 - W_2)}{(W_1 + W_2)}$$

from which  $\phi$  and power factor of the load may be found.

**Example 1:** Two wattmeters connected to measure the power input to a balanced three-phase circuit indicate 4.5 KW and 3 KW respectively. Find the power factor of the circuit.

Solution

$$\tan \phi = \frac{\sqrt{3}(P_1 - P_2)}{(P_1 + P_2)}$$

$$P_1 = 4.5 \text{ KW}$$

$$P_2 = 3 \text{ KW}$$

$$P_1 + P_2 = 4.5 + 3 = 7.5 \text{ KW}$$

$$P_1 - P_2 = 4.5 - 3 = 1.5 \text{ KW}$$

$$\tan \phi = \frac{\sqrt{3} \times 1.5}{7.5} = \frac{\sqrt{3}}{5} = 0.3464$$

$$\phi = \tan^{-1} 0.3464 = 19^{\circ}6'$$

$$\text{Power factor } \cos 19^{\circ}6' = 0.95$$

**Example 2:** Two wattmeters connected to measure the power input to a balanced three-phase circuit indicate 4.5 KW and 3 KW respectively. The latter reading is obtained after reversing the connection of the voltage coil of that wattmeter. Find the power factor of the circuit.

**Solution**

$$\tan \phi = \frac{\sqrt{3}(P_1 - P_2)}{(P_1 + P_2)}$$

$$= \frac{\sqrt{3}(4.5 - (-3))}{(4.5 + (-3))}$$

$$= \frac{\sqrt{3}(4.5 + 3)}{(4.5 - 3)}$$

$$= \frac{\sqrt{3} \times 7.5}{1.5} = \sqrt{3} \times 5$$

$$= 1.732 \times 5 = 8.66.$$

$$\phi = \tan^{-1} 8.66 = 83^{\circ}.27'$$

$$\text{since power factor } (\cos 83^{\circ}27') = 0.114.$$

**Example 3:** The reading on the two wattmeters connected to measure the power input to the three-phase, balanced load are 600W and 300W respectively.

Calculate the total power input and power factor of the load.

**Solution**

$$\text{Total power} = P_T = P_1 + P_2$$

$$P_1 = 600\text{W.}$$

$$P_2 = 300\text{W.}$$

$$P_T = 600 + 300 = 900$$

$$\tan \phi = \frac{\sqrt{3}(P_1 - P_2)}{(P_1 + P_2)} = \frac{\sqrt{3}(600 - 300)}{600 + 300} = \frac{\sqrt{3} \times 300}{900}$$

$$= \frac{\sqrt{3}}{3} = \frac{1}{\sqrt{3}} = 0.5774$$

$$\phi = \tan^{-1} 0.5774 = 30^{\circ}$$

$$\text{Power factor} = \cos 30^{\circ} = 0.866.$$

**Assignment**

Two wattmeters connected to measure the power input to a balanced, three-phase load indicate 25KW and 5KW respectively.

Find the power factor of the circuit when (i) both readings are positive and (ii) the latter reading is obtained after reversing the connections of the pressure coil of the wattmeter.

**Tong - tester (clamp - on ammeter)**

**Objectives:** At the end of this lesson you shall be able to

- state the necessity of tong-testers
- state the construction and working of a tong-tester
- state the precautions to be observed while using a tong-tester.

A tong-tester is an instrument devised for the measurement of A.C current, without interrupting the circuit. It is also called clip-on ammeter, or sometimes a clamp-on ammeter (Fig 1).

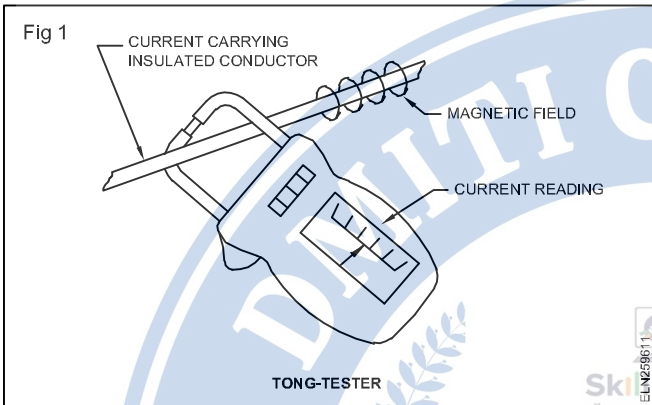

**Working principle**

The instrument can function only when current passes through its deflecting system. It works under the mutual induction principle.

**Electromagnetic induction:** When a changing flux is linked with the coil, an emf is induced in the coil. The current in a coil so produced changes as that of the changing magnetic flux. If an alternating current is flowing through the coil, the magnetic flux produced is also alternative i.e. changing continuously.(Fig 2)

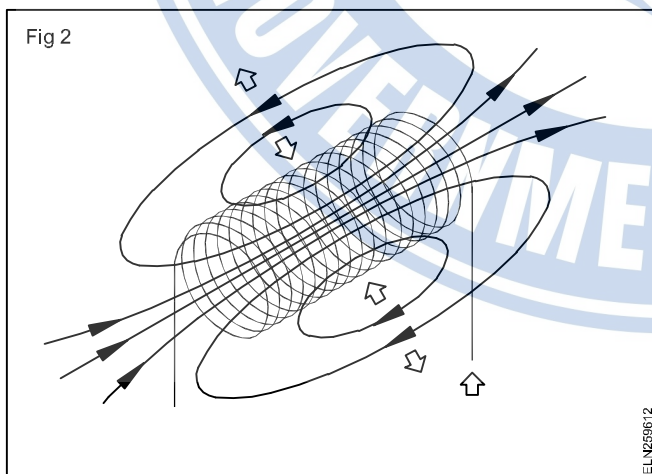

Placing another coil (2) in the changing flux of coil (1), an emf will be induced. (Fig 3)

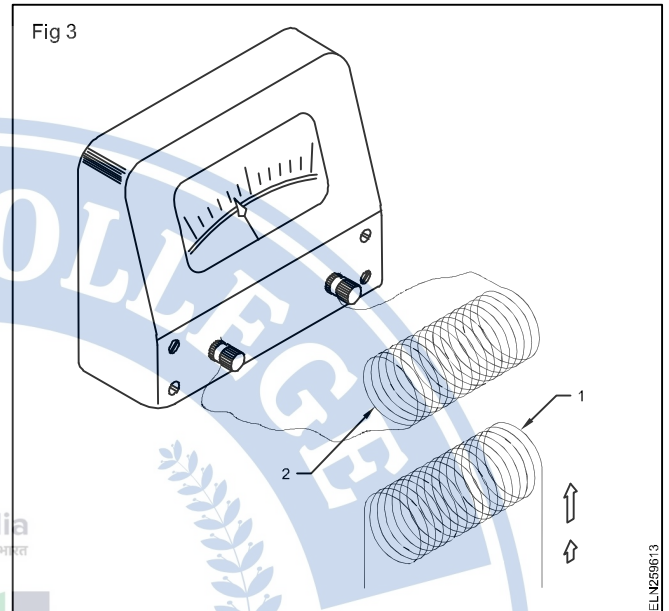

This induced emf will send the current, causing deflection of the meter. Introduction of a magnetic core between the coils increases the induced emf. The coil (1) is called primary and the coil (2) is called secondary.

**Construction:** Fig 4 shows a tong-tester (the clamp-on ammeter) circuit. The split-core meter consists of a secondary coil with the split-core and a rectifier type instrument connected to the secondary. The current to be measured in the conductor serves as the primary of one turn coil. It induces a current in the secondary winding and this current causes the meter to deflect.

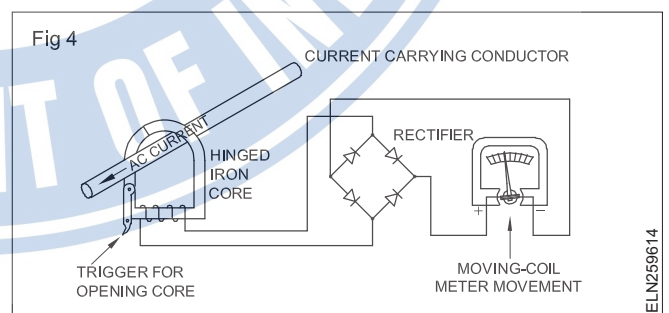

The core is so designed that there is only one break in the magnetic path. The hinge and the opening both fit tightly when the instrument closes around the conductor. The tight fit of the instrument ensures minimum variation in the response of the magnetic circuit.

To measure current with a clamp-on meter, open the jaws of the instrument and place them around the conductor in which you want to measure the current. Once the jaws are in place, allow them to close securely. Then, read the indicator position on the scale.

When the core is clamped around a current-carrying conductor, the alternating magnetic field induced in the core, produces a current in the secondary winding.

This current causes a deflection on the scale of the meter movement. The current range can be changed by means of a 'range switch', which changes the taps on the transformer secondary (Fig 5).

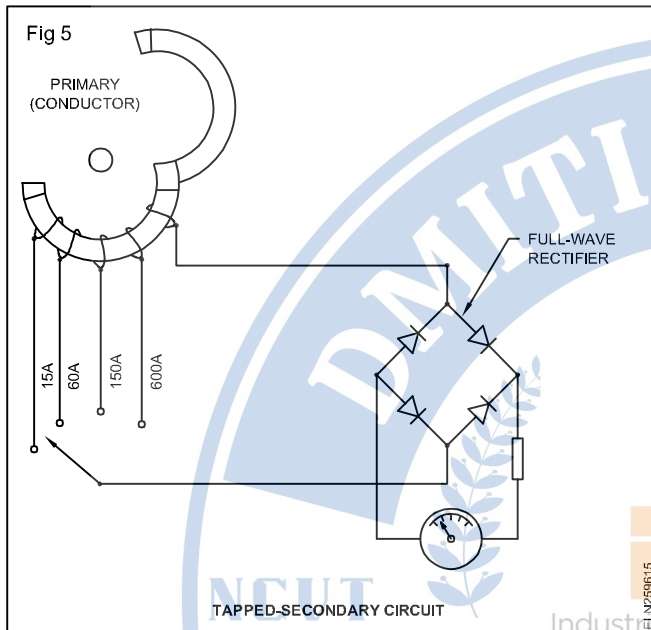

**Safety:** The secondary winding of the current transformer should always be either shunted or connected to the ammeter; otherwise, dangerous potential differences may occur across the open secondary.

Before taking any measurement, make sure the indication is at zero on the scale. If it is not, reset by the zero-adjustment screw. It is usually located near the bottom of the meter.

Looping the conductor more than once through the core is another means of changing the range. If the current is far below the meter's maximum range, we can loop the conductor through the core two or more times (Fig 6).

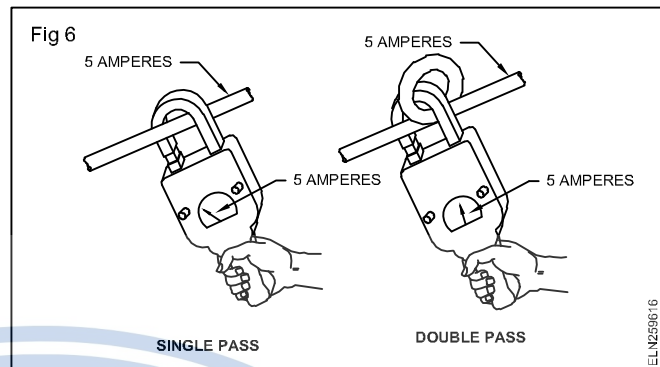

### Application

- 1 For measuring the incoming current in the main panel board.
- 2 Primary current of AC welding generators.
- 3 Secondary current of AC welding generators.
- 4 Newly rewinded AC motor phase current and line current.
- 5 Starting current of all AC machines.
- 6 Load current of all AC machines and cables.
- 7 For measuring the unbalanced or balanced loads.
- 8 For finding the faults in AC, 3-phase induction motors.

### Precaution

- 1 Set the ampere range from higher to low if the measuring value is not known.
- 2 The ampere-range switch should not be changed when the clamp is closed.
- 3 Before taking any measurement make sure the indication is at zero on the scale.
- 4 Do not clamp on a bare conductor for current measurement.
- 5 Seating of the core should be perfect.

## **Smartmeters - Automatic meter reading - Supply requirements**

**Objectives:** At the end of this lesson you shall be able to

- understand construction of smart meter
- explain the working of smart meter.

### **Smart Meter**

Now a days smartmeters are used to measure the electricity consumption of a building. Smart meters offer more detailed data than the old meters. They also give customers the updated power usage data. By this they control their power usage.

Smart meters measures not only energy but also measures voltage, frequency and KVA also. It delivers information wirelessly via low energy radio frequency waves to the competent authorities (EB).

### **Automatic meter reading**

Automatic meter reading or AMR is the Technology of automatically collecting consumption, diagnostic and status data from energymetering devices and transferring that data to the central data base for billing, trouble shooting and analyzing.

AMR which works by translating the movement of mechanical dials on a meter into a digital signal, does not require physical access or visual inspection

An AMR meter works by creating a connection channel between a business customer and its energy supplier. For an AMR meter the communication only goes in one direction, to the supplier. The energy supplier will receive meter reading once per month, so there is no need for manual reading.

Smartmeters works by using a secure national communication network. Smartmeters are the new generation of energy meters while AMR is an attached device that transmits the meter reading.

The most note worthy advantages for using these system are increased efficiencies, outage detection, tamper notification and reduced labour cost, smart meters usually use wireless signals at 2.4 GHZ with a maximum power of less than one watt.

The smartmeters should have the following minimum basic features:

- Measurement of electrical energy parameters
- Bidirectional communication
- Integarated load limiting switch relay
- Tamper event deduction, recording and reporting
- Power event alarm
- Remote firmware upgrade
- Netmetering (kwh) features

### **Electrical supply requirements of smart meter**

For smartmeters, selecting the appropriate power supplies is essential to ensure optimal safety standards and lower the chances of malfunctioning in field developments. For this reason the authorities should consider some of the power supply requirements for smart energy metering system application. Some of the factors to consider include the followig.

- 60 - 230V Ac stable input
- Transient power of 6.72 W
- EMI class B with surge voltage to (or) over 2KV  
(EMI - Electro magnetic interference)

### **Detecting /clearing the tamper notification on meter**

Meter tampering means doing any act, which causes the meter to run slower or not at all and is basically theft of electricity from the authorities that supply electrical power.

The tamper notification (or) anti theft device is designed to detect the tamper in the energy meter of residential areas and notifies it to the power company through SMS.

The device detects the tampering through the reading of the to current sensors that are connected to a micro controller.

The power company will get notified, when one of the current sensors detects current, while the other one has not or there is a difference from the reading of the to current sensors. This systems also notifies the authority with an average time of 17.61 sec. Upon notification the power company immediately disconnect the line.

To detect electricity theft in an area, a temperature dependent predictive model which uses smart meter data and data from distribution transformer.

### **Distributed generation and prosumer**

Distributed generation (DG) refers to a variety of technologies that generate electricity at (or) near where it will be used such as solar panels and combined heat and power. Distributed generation is generation of electricity located in the distribution grid.

A 'prosumer' is an individual who both consumes and produces energy. He also produce and share surplus energy whith grid and other users.

**Extension of range of MC voltmeters - loading effect - voltage drop effect**

**Objectives:** At the end of this lesson you shall be able to

- state the function of the additional series resistance in a voltmeter
- calculate the value of the total resistance of the meter with respect to voltage and full scale deflection of current
- determine the resistance of a multiplier.

**Meter movement:** A basic current meter movement by itself can be used to measure voltage. You know that every meter coil has a fixed resistance, and, therefore, when current flows through the coil, a voltage drop will be developed across this resistance. According to Ohm's Law, the voltage drop (E) will be proportional to the current flowing through the coil of resistance R ( $E = IR$ ).

For example, in Fig 1 you have a 0-1 milliamperere meter movement with a coil resistance of 1000 ohms. When 1 milliamperere is flowing through the meter coil and is causing f.s.d. the voltage developed across the coil resistance will be:

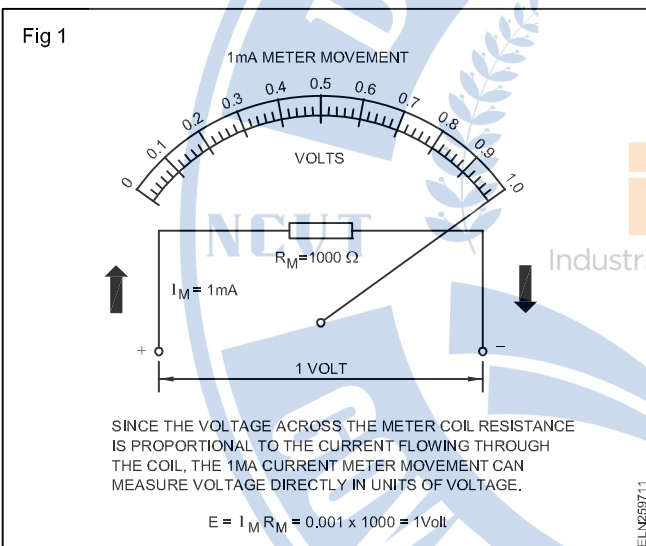

$$E = I_M R_M = 0.001 \times 1000 = 1 \text{ volt.}$$

If only half that current (0.5 milliamperere) was flowing through the coil, then the voltage across the coil would be:

$$E = I_M R_M = 0.0005 \times 1000 = 0.5 \text{ volt.}$$

It can be seen that the voltage developed across the coil is proportional to the current flowing through the coil. Also, the current that flows through the coil is proportional to the voltage applied to the coil. Therefore, by calibrating the meter scale in units of voltage instead of in units of current, the voltage in various parts of a circuit can be measured.

Although a current meter movement inherently can measure voltage, its usefulness is limited because the current that the meter coil can handle, as well as its coil resistance, are very low. For example, the maximum voltage you could measure with the 1 milliamperere meter movement in the above example is 1 volt. In actual practice, voltage measurements higher than 1 volt will be required.

**Multiplier resistors:** Since a basic current meter movement can only measure very small voltages, The voltage range of a meter movement can be extended by adding a resistor, in series. The value of this resistor must be such that, when added to the meter coil resistance, the total resistance limits the current to the full-scale current rating of the meter for any applied voltage.

For example, suppose one wanted to use the 1-milliamperere, 1000-ohms meter movement to measure voltages up to 10 volts. From Ohm's Law, it can be seen that, if the movement is connected across a 10-volt source, 10 milliampereres would flow through the movement and would probably ruin the meter ( $I = E/R = 10/1000 = 10$  milliampereres).

But the meter current can be limited to 1 milliamperere if a multiplier resistor ( $R_{MULT}$ ) is added in series with the meter resistance ( $R_M$ ). Since a maximum of only 1 milliamperere can flow through the meter, the total resistance of the multiplier resistor and the meter ( $R_{TOT} = R_{MULT} + R_M$ ) must limit the meter current to one milliamperere. By Ohm's Law, the total resistance is

$$R_{TOT} = E_{MAX} / I_M = 10 \text{ volts} / 0.001 \text{ ampere} = 10,000 \text{ ohms.}$$

But this is the total resistance needed. Therefore, the multiplier resistance is

$$R_{MULT} = R_{TOT} - R_M = 10000 - 1000 = 9000 \text{ ohms.}$$

The basic 1-milliamperere, 1000-ohms meter movement can now measure 0-10 volts, because 10 volts must be applied to cause a full-scale deflection. However, the meter scale must now be re-calibrated from 0-10 volts, or, if the previous scale is used all the reading should be multiplied by 10 (Fig 2).

**Multiplying factor (M.F)**

$$MF = \frac{\text{Proposed voltmeter range (V)}}{\text{Voltage drop across MC at FSD}} = \frac{V}{v}$$

Calculating the multiplier resistance using M F

$$R_{MULT} = (MF - 1) R_M$$

where

$R_{MULT}$  = Multiplier resistance

M F = Multiplying factor

$R_M$  = Meter resistance

**Example :** A 1 mA meter has a coil resistance of 1000 ohms. What value of multiplier resistor is needed to measure 100V?

$$MF = \frac{V}{v}$$

$$v = I_M \times R_M$$

$$= 1 \times 10^{-3} \times 1000 = 1V$$

$$MF = \frac{V}{v} = \frac{100}{1} = 100$$

$$R_{MULT} = (MF - 1)R_M = (100 - 1)1000$$

$$= 99,000 \text{ ohms.}$$

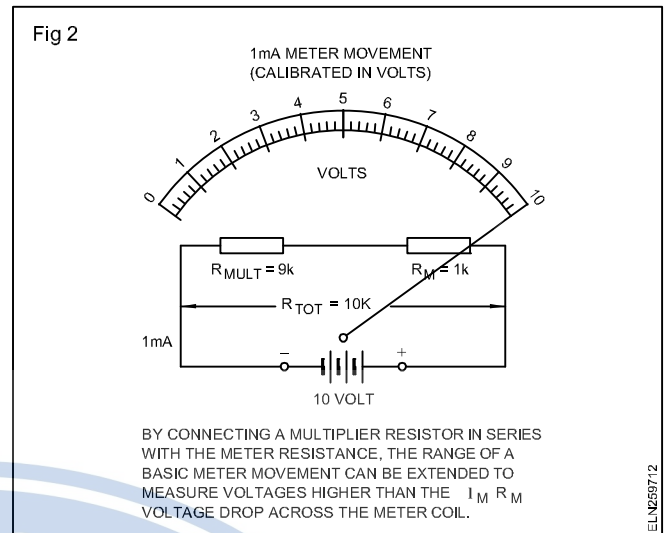

## Extension of range of MC ammeters

**Objectives:** At the end of this lesson you shall be able to

- define shunt used in ammeter
- calculate a shunt resistance to extend the range of an ammeter
- name the material used for shunt
- apply the use of terminals in standard shunts.

**Shunts:** Moving coils of basic meters by themselves cannot carry large currents, since they are made of fine wire. To measure a current greater than that which the moving coil can carry, a low resistance, called a SHUNT, is connected across the instrument terminals (Fig 1).

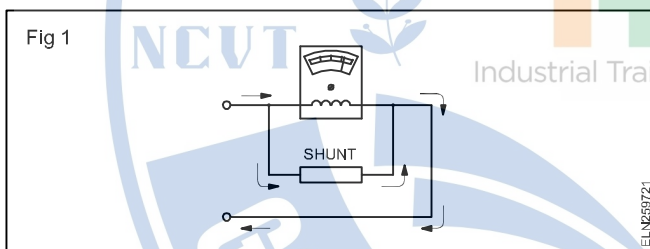

The shunt, therefore, makes it possible to measure currents much greater than that could be measured by the basic meter alone.

**The shunt equation:** A meter and shunt combination is identical to the parallel circuit shown in Fig 2. Instead of labelling the top resistor  $R_2$ , it can be labeled  $R_M$ , which represents the resistance of the moving coil. Resistor  $R_1$  can be labeled  $R_{SH}$  to represent the resistance of the shunt.  $I_{R1}$  and  $I_{R2}$  then become  $I_{SH}$  and  $I_M$  to indicate the current flow through the shunt and through the meter. This means that the equation  $I_{R1} R_1 = I_{R2} R_2$  can now be written as  $I_{SH} R_{SH} = I_M R_M$ .

Therefore, if three of these values are known, the fourth can be calculated. Since the shunt resistance  $R_{SH}$  is always the unknown quantity, the basic equation

$$I_{SH} R_{SH} = I_M R_M \text{ becomes } R_{SH} = \frac{I_M R_M}{I_{SH}}$$

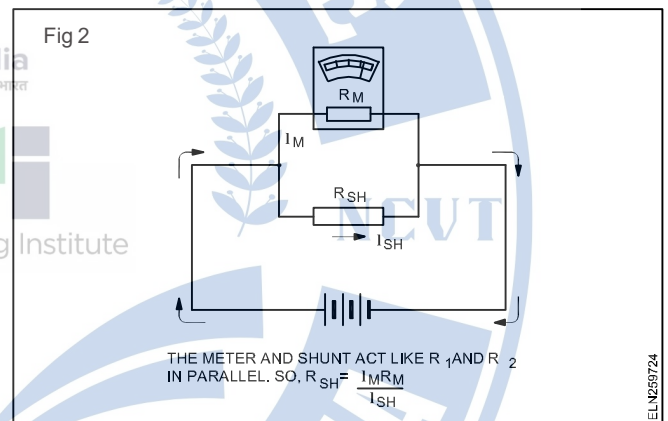

From this equation, shunts can be calculated to extend the range of a current meter to any value,

where  $R_{SH}$  = shunt resistance

$I_M$  = meter current

$R_M$  = resistance of moving coil instrument

$I_{SH}$  = current flow through shunt.

The value of current through the shunt ( $I_{SH}$ ) is simply the difference between the total current you want to measure, and the actual full-scale deflection of the meter.

$$I_{SH} = I - I_M \text{ where } I = \text{total current.}$$

The meter and shunt act like  $R_1$  and  $R_2$  in parallel. So,

$$R_{SH} = \frac{I_M R_M}{I_{SH}}$$

**Calculating shunt resistance:** Assume that the range of a one milliamperere meter movement is to be extended to 10 milliamperes, and the moving coil has a resistance of 27 ohms. Extending the range of the meter to 10 milliamperes

means that 10 milliamperes will be flowing in the overall circuit when the pointer is deflected full scale. (Fig 3)

$$I_M = 1 \text{ mA (0.001 A)}$$

$$I = \text{Current to be measured} = 10 \text{ mA}$$

$$R_M = 27 \text{ Ohms}$$

$$I_{SH} = I - I_M = 10 \text{ mA} - 1 \text{ mA}$$

$$= 9 \text{ mA (0.009 A)}$$

$$R_{SH} = \frac{I_M R_M}{I_{SH}} = \frac{0.001 \times 27}{0.009} = 3 \text{ ohms.}$$

**Shunt material:** The resistance of shunt should not vary due to the temperature. The shunt is usually made of Manganin which has negligible temperature coefficient of resistance. A high current shunt of a switch board instrument is shown in Fig 4.

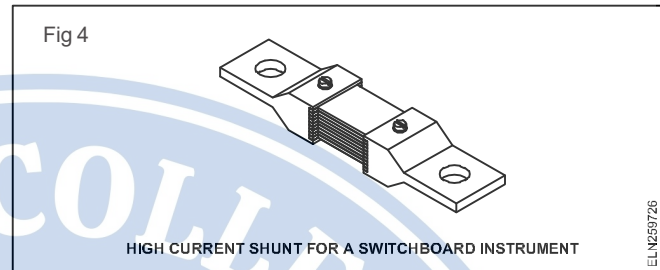
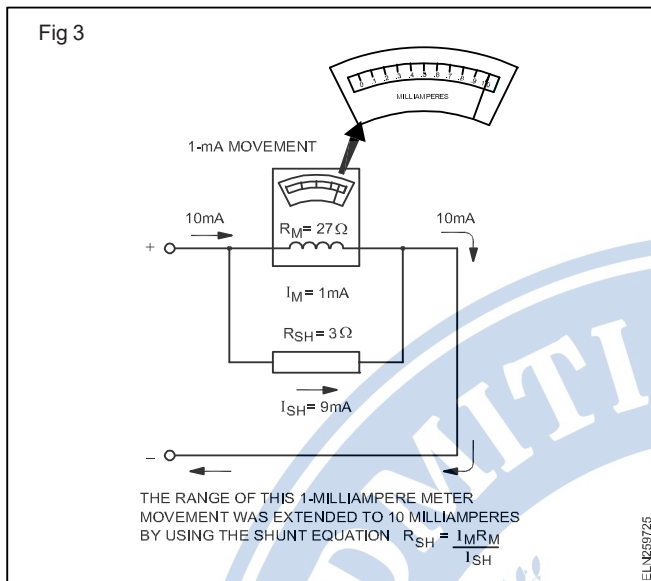

## Calibration of MI Ammeter and Voltmeter

**Objectives:** At the end of this lesson you shall be able to

- define the term 'calibration'
- explain the calibration of voltmeter and ammeter.

### Calibration

In many industrial operations, measurement instruments must be trusted to provide the accuracy stipulated by the original design to assure a satisfactory product. This confidence is provided by a periodic testing and adjustment of the instrument to verify the required performance. This type of maintenance is called calibration.

### Standards

Before calibration can begin, you must have the accurately known values of the measured quantities against which to compare the measurements made by the instrument being calibrated. Thus, for an instrument that is supposed to measure current of 1 milli ampere, you must have, for comparison, a source of current that is known to within at least that range or better. Only then you can say whether the instrument performs satisfactorily.

A very accurately known quantity used for calibration of instruments is known as a standard.

#### Calibration standards

Quantity	Standard
Voltage	Standard cell, high precision source
Current	Voltage standard and standard resistance standard milli volt source, gas filled/ mercury filled thermometers.

### Calibrating DC and AC meters (Ammeter & Voltmeter)

Both DC and AC meters are calibrated in essentially the same way. To calibrate a DC meter, a very accurate DC current source is connected to the meter. The output of the current source must be variable, and some means must be available to monitor the output current of the source. Many sources have built-in meter for this purpose.

The output of the current source is varied in very small steps, and at each step the scale of the meter being calibrated is marked to correspond to the reading on the monitoring device. This procedure is continued until the entire scale of the meter is calibrated.

Same procedure is used to calibrate an AC meter, except that a 50/60 cps sine wave is used mostly. Also, you know that an a-c meter reads the average value of a sine wave, but it is desirable for the meter to indicate rms values. Therefore the rms equivalent are calculated and marked on the scale.

Thermocouple meters are calibrated on the basis of a sine wave. But the calibration is made at the frequency at which the meter will be used. At the extremely high frequencies at which it is used, a phenomenon known as skin effect occurs.

At these frequencies, the current in a wire travels at the surface of the wire, the higher the frequency, the closer the current moves to the surface of the wire. This effect

increases the resistance of the thermocouple heater wire because the diameter of the wire becomes, in effect, smaller.

Thus the resistance of the heater wire varies with frequency. Since the resistance of the heater wire varies with frequency, thermocouple meters must be calibrated at specific frequencies.

**Precautions to be observed when using an ammeter in measurement work**

- 1 Never connect an ammeter across a source of EMF. Because of its low resistance it would draw damaging high currents and damage the delicate movement. Always connect an ammeter in series with a load capable of limiting the current.

- 2 Observe the correct polarity. Reverse polarity causes the meter to deflect against the mechanical stop and this may damage the pointer.

**METER ACCURACY**

METER	TYPICAL ACCURACY
Moving coil	0.1 to 2%
Moving iron	5%
Rectifier type moving coil	5%
Thermocouple	1 to 3%

**Loading effect of voltmeter and voltage drop effect of ammeter in circuits**

**Objectives:** At the end of the lesson you shall be able to

- define the term 'multiplier'
- analyse the loading effect of the voltmeter
- analyse the effect of voltage drop across the ammeter in the resistance measurement.

**Multipiler**

In the case of P.M.M.C. instruments, we have seen that the moving coil consists of fine gauge copper wire. This copper wire can carry very low current in the order of milli or micro amperes only.

The acceptable current which enables the instrument to read full scale is called full scale deflection current or F.S.D. current. When such a P.M.M.C. instrument is to be converted as a voltmeter, the moving coil has to be connected with a high resistance in series so that the current could be restricted within the F.S.D. current value. This series resistance is called **multiplier** resistance.

Let us study how the voltmeter sensitivity causes loading effect in the circuit by the voltmeter.

**Loading effect of a voltmeter:** The sensitivity of a voltmeter is an important factor when selecting a meter for a certain voltage measurement. A low sensitivity voltmeter may give an almost correct reading when measuring voltages in low-resistance circuits, but it is certain to produce very high errors in high resistance circuits. It is due to the fact that the voltmeter, when connected across a high resistance circuit, acts as a shunt for that portion of the circuit, and, thereby, reduces the equivalent resistance in that portion of the circuit.

As such, the meter will then give a lower indication of the voltage drop than what actually existed before the meter was connected. This effect is called the loading effect of a voltmeter and it is caused principally by the low sensitivity of the voltmeter.

The meter with the higher sensitivity of ohms/volt rating gives the most reliable result. It is important to realize the factor of sensitivity, particularly when voltage measurements are made in high-resistance circuits. Hence the following points are required to be followed while using a voltmeter.

- When using a multi-range voltmeter, always use the highest voltage range, and then decrease the range until a good up-scale (above mid-scale) reading is obtained.
- Always be aware of the loading effect. This effect can be minimised by using a voltmeter of high sensitivity and highest range in voltmeter.
- Before reading the meter, try to select a range in the multi-scale instrument such that the reading obtained is above mid-scale. The precision of the measurement decreases if the indication is at the low end of the scale.

**Effect of voltage drop across the ammeter in resistance measurement:** The ammeter/voltmeter method of measuring resistance is very popular since the instrument required for this is usually available in the laboratory.

In this method, two types of connections of meters are possible (Figs 1a and b).

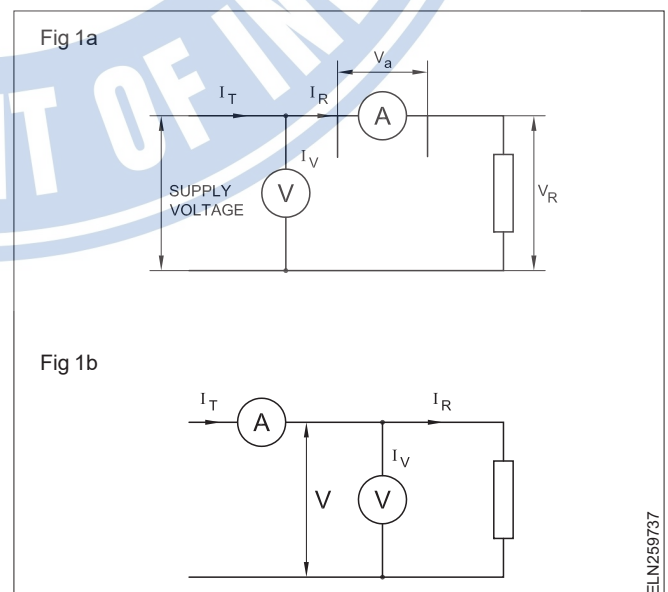

In both the cases, if readings of the ammeter and voltmeter are taken, then the measured value of resistance is given by

$$R_m \frac{\text{Voltmeter reading}}{\text{Ammeter reading}} = \frac{V}{I}$$

The measured value of resistance  $R_m$ , would be equal to the true value  $R$ , provided the ammeter resistance is zero and the voltmeter resistance is infinite, to make the circuit condition undisturbed.

However, in practice this is not possible, and hence, both the methods give inaccurate results. But the error in measurement could be reduced under different values of resistance to be measured as explained below.

**Circuit (Fig 1a):** In this circuit, the ammeter measures the true value of the current through the resistor. But the voltmeter does not read the true voltage across the resistance. On the other hand, the voltmeter measures the voltage drop across the resistance and also the ammeter.

Let  $R_a$  be the resistance of the ammeter.

Then the voltage drop across the ammeter  $V_a = IR_a$

$$R_{m1} = \frac{V}{I} = \frac{V_R + V_a}{I_R} = \frac{IR + IR_a}{I_R} = R + R_a \dots \text{Eqn. (1)}$$

true value of resistance  $R = R_{m1} - R_a \dots \text{Eqn. (2)}$

From equation 2, it is clear that the measured value of resistance is higher than the true value. It is also clear from the above equation, that the true value is equal to the measured value only if the ammeter resistance  $R_a$  is zero.

$$\begin{aligned} \text{Relative error } e_r &= \frac{R_{m1} - R}{R} \\ e_r &= \frac{R_{m1} - (R_{m1} - R_a)}{R} \\ &= \frac{R_a}{R} \dots \text{Eqn. (3)} \end{aligned}$$

**Conclusion:** From equation 3, it is clear that the error in measurement would be small if the value of resistance under measurement is large as compared to the internal resistance of the ammeter. Therefore, the circuit shown in Fig 1(a) is most suitable for measuring high resistance values only.

**Circuit (Fig 1b):** In this circuit the voltmeter measures the true value of the voltage across the resistance but the ammeter measures the sum of currents through the resistance and the voltmeter.

Let  $R_v$  be the resistance of the voltmeter. Then the current through the voltmeter

$$I_v = \frac{V}{R_v}$$

Measured value of the resistance

$$\begin{aligned} R_{m2} &= \frac{V}{I} = \frac{V}{I_R + I_v} \\ R_{m2} &= \frac{V}{\frac{V}{R} + \frac{V}{R_v}} \dots \text{Eqn. (4)} \end{aligned}$$

By multiplying the denominator and numerator by  $\frac{R}{V}$ , Eqn.(4) becomes

$$R_{m2} = \frac{R}{1 + \frac{R}{R_v}} \dots \text{Eqn. (4)}$$

From equation 4, it is clear that the true value of resistance is equal to the measured value only if

- the resistance of the voltmeter  $R_v$  is infinite
- the resistance to be measured 'R' is very small when compared to the resistance of the voltmeter.

$$\text{Relative error } e_r = \frac{R_{m2} - R}{R}$$

By elimination process, we get  $\dots \text{Eqn. (5)}$

The value of  $R_{m2}$  is approximately equal to  $R$ .

$$\text{Therefore } e_r = \frac{-R}{R_v} \dots \text{Eqn. (6)}$$

**Conclusion:** From equation (6), it is clear that the error in measurement would be small if the value of resistance under measurement is very small as compared to the resistance of the voltmeter. Hence the circuit shown in Fig 1(b) should be used when measuring resistances of a lower value.