

Ohm's law - simple electrical circuits and problems



Scan the QR Code to view the video for this exercise

Objectives: At the end of this lesson you shall be able to

- state Ohm's law
- apply Ohm's law in an electric circuit.
- define electrical power and energy and calculate related problems.

Simple electric circuit

In the simple electric circuit shown in Fig 1, the current completes its path from the positive terminal of the battery via the switch and the load back to the negative terminal of the battery.

The circuit shown in Fig 1 is a closed circuit. In order to make a circuit to function normally the following three factors are essential.

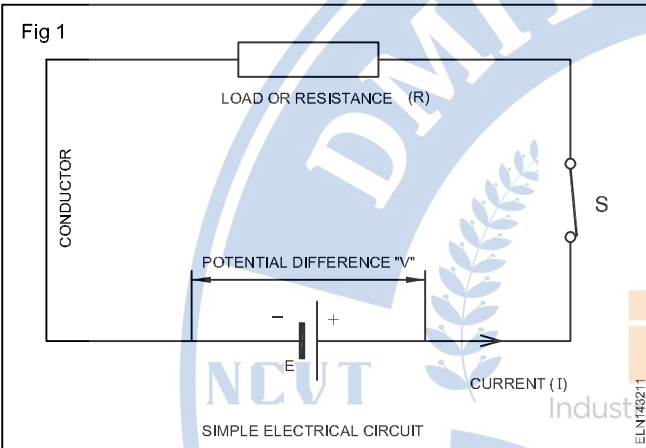

- Electromotive force (EMF) to drive the electrons through the circuit.
- Current (I), the flow of electrons.
- Resistance (R) - the opposition to limit the flow of electrons.

Ohm's law

Ohm's law states that in any electrical closed circuit, the current (I) is directly proportional to the voltage (V), and it is inversely proportional to the resistance 'R' at constant temperature.

$$I \propto \frac{V}{R}$$

It means $I = V/R$

V = Voltage applied to the circuit in 'Volt'

I = Current flowing through the circuit in 'Amp'

R = Resistance of the circuit in Ohm (Ω)

The above relationship can be referred to in a **triangle** as shown in Fig 2. In this triangle whatever the value you want to find out, place the thumb on it then the position of the other factors will give you the required value.

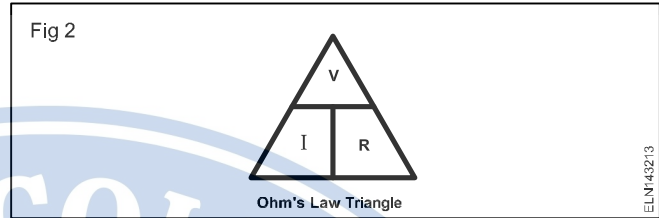

For example for finding 'V' close the value V then, readable

$$I = \frac{V}{R}$$

values are IR so, $V = IR$

$$R = V/I$$

$$I = V/R$$

Example 1

How much current (I) flows in the circuit shown in Fig 3.

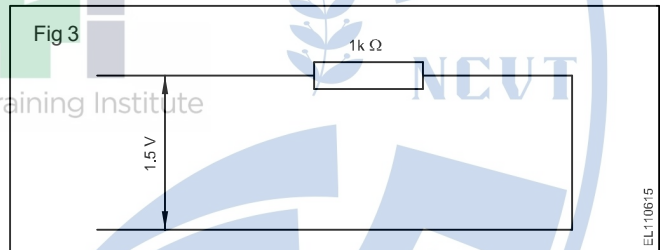

Given:

Voltage (V) = 1.5 Volts

Resistance (R) = 1 kOhm
= 1000 Ohms

$$I = \frac{V}{R}$$

Solution:

$$I = \frac{1.5 \text{ V}}{1000 \text{ Ohms}} = 0.0015 \text{ amp}$$

Electrical Power (P) & Energy (E): The product of voltage (V) and current (I) is called electrical power. Electrical power (P) = Voltage x Current $P = V \times I$

The unit of Electrical power is 'Watt' It is denoted by the letter 'P' It is measured by Watt meter. The following formulae can also be derived from formula of power (P) as

- i $P = V \times I$
- $= IR \times I$
- $P = I^2 R$

ii $P = V \times I$

$$= V \times \frac{V}{R}$$

$$P = \frac{V^2}{R}$$

Electrical Energy (E)

The product of power (P) and time (t) is called as electrical energy (E)

Electrical Energy (E) = Power x time

$$E = P \times t$$

$$= (V \times I) \times t$$

$$E = V \times I \times t$$

The unit of electrical energy is “Watt hour” (Wh)

The commercial unit of Electrical energy is “Kilo watt hour” (KWH) or unit

B.O.T (Board of Trade) unit / KWH/Unit

One B.O.T (Board of Trade) unit is defined as that one thousand watt lamp is used for one hour time, it consumes energy of one kilowatt hour (1kWH). It is also called as “unit”

$$\text{Energy} = 1000W \times 1\text{Hr} = 1000WH \text{ (or) } 1kWH$$

Example - 1

How much electrical energy is consumed in an electric iron rated as 750W/250V used for 90 Minutes

Given:

Power (P) = 750W

Voltage (V) = 250V

Time = 90min (or) 1.5Hr

Find:

Electrical Energy (E) = ?

Solution:

$$\text{Electrical Energy (E)} = P \times t$$

$$= 750 \text{ w} \times 1.5\text{Hr}$$

$$\longrightarrow = 1125 \text{ WH (or)}$$

$$E = 1.125 \text{ kWH}$$

Work, Power and Energy

Work is said to be done, when a force (F) displaces a body from one distance (s) to another (or)

$$\text{Work done} = \text{Force} \times \text{distance moved}$$

$$w.d = F \times S$$

It is generally denoted as “W”

The unit of work done is

i In Foot Pound Second (F.P.S) System is “Foot Pound (lb.ft)”

ii In Centimetre Gram Second (C.G.S) System “Gram Centimetre (gm.cm)”

or

$$1 \text{ gm.cm} = 1 \text{ dyne}$$

$$1 \text{ dyne} = 10^7 \text{ ergs}$$

The smallest unit of work done is “Erg”

iii In Metre - Kilogram - Second (M.K.S.) System is “Kilogram Metre (Kg-M)”

$$1 \text{ Kilogram} = 9.81 \text{ Newton}$$

iv In system of international unit (S.I. Unit) is ‘Joule’

$$1 \text{ Joule} = 1 \text{ Newton Metre (Nw-M)}$$

Power (P)

The rate of doing work is called as Power (P)

Power (P) = work done / time taken

$$P = \frac{F \times S}{t}$$

It’s unit is Lb.ft/sec in FPS system

gm-cm/sec is in C.G.S. System

(or)

Dyne/sec

(or)

Kg-M/sec in M.K.S System (or) NW - M/ sec

$$(1\text{kg} = 9.81 \text{ Newton})$$

Joule/sec in (S.I)

$$1 \text{ Joule/Sec} = 1 \text{ watt}$$

$$\text{Electrical Power} = VI \text{ Watt}$$

The unit of Mechanical power is “Horse Power” (H.P)

Horse Power (HP) further classified into two:

They are:-

Indicated Horse Power - (IHP)

Brake Horse Power - (BHP)

Indicated Horse Power (IHP)

The power developed inside the engine (or) pump (or) motor is called Indicated Horse Power (IHP)

Brake Horse Power (BHP)

The useful Horse Power which is available at the shaft of the engine/motor/pump is called Brake Horse Power (BHP)

So, IHP is always greater than

BHP due to friction losses

$$IHP > BHP$$

The relation between Mechanical and Electrical Power

- (ie) 1 HP (British) = 746 Watt
 1 HP (Metric) = 735.5 Watt

One HP (Metric)

The amount of Mechanical Power required to move/displace a body/substance by force of 75 Kg to one metre distance in one second is called as one HP (metric)

HP (Metric) = 75kg - M/Sec

One HP (British)

The amount of Mechanical power required to move/displace a body/substance of force 550lb to one foot (ft) distance in one second is called as one HP (British)

1 HP (British) = 550 lb.ft/sec

Energy

The capacity for doing work is called as electrical Energy

(or)

The product of power and time is known as Electrical energy

(ie) Energy = Power x time
 = VI x t

S.I unit of energy is "Joule"

(ie) Energy = (Joule/sec) x sec

$$= \frac{\text{Joule}}{\text{Sec}} \times \text{Sec} = \text{joule}$$

(ie) The S.I of unit of work done and energy is same (Joule)

The energy can be divided into two main categories (ie)

- (i) Potential Energy (eg. Loaded gun, energy (stored in spring etc)
- (ii) Kinetic Energy (eg. Moving of car, raining etc).

Example

In a house, the following electrical loads are daily used:-

- (i) 5 Nos of 40W Tube Lights used for 5 hours/day
- (ii) 4 Nos of 80W fans used for 8 hours/day
- (iii) 1 No of 120W T.V. receiver used for 5 hours/day
- (iv) 4 No of 60W lamps used for 4 hours/day

Calculate the total energy consumed in unit's per day and also the cost of electric bill for the month of January If the cost of energy is 1.50/unit

Given

Load details per day

Electric Device	Power	Numbers	Time in hours
(i) Tube light	40W	5	5 hr/day
(ii) Fans	80W	4	8 hr/day
(iii) T.V.	120W	1	6 hr/day
(iv) Lamps	60W	4	4 hr/day

cost of energy - Rs.1.50/unit

Find:

- (i) Energy consumption in unit per day = ?
- (ii) Cost of energy for the month of January = ?

Solution

Energy consumption/day

1. Tubelight = 40W x 5 x 5 hr /day

$$= \frac{1000 \text{ wh}}{1000} = 1\text{Kwh/day}$$

2. Fans = 80W x 4x8 hr/day

$$= \frac{2560}{1000} = 2.56\text{Kwh/day}$$

3. T.V. = 120W x 1x6 hr/day

$$= \frac{720 \text{ wh}}{1000} = 0.72\text{Kwh/day}$$

4.Lamp = 60W x 4x4 hr/day

$$= \frac{960}{1000} = \text{Kwh} = \frac{0.96\text{kwh/day}}{5.24\text{kwh/day}}$$

(i) Total energy consumption in unit per day = 5.24 unit

(ii) Total energy consumption for the month of January (i.e 31 days)
 = 5.24 x 31
 = 162.44 units

Cost of energy = Rs. 1.50/unit

Total electric bill for the month of January = 162.44 x 1.50
 = Rs.243.66

Electricity Bill for the month = Rs. 244/-

Kirchhoff's law and its applications

Objectives: At the end of this lesson you shall be able to

- state Kirchhoff's first law
- apply Kirchhoff's first law to find the circuit current
- state Kirchhoff's second law and apply the same to find the voltage drop in branches
- solve problems by applying Kirchhoff's laws.

Kirchhoff's laws are used in determining the equivalent resistance of a complex network and the current flowing in the various conductors.

Kirchhoff's laws

Kirchhoff's first law: At each junction of currents, the sum of the incoming currents is equal to the sum of the outgoing currents. (Fig 1) (or) The algebraic sum of all branch currents meeting at a point/node is zero

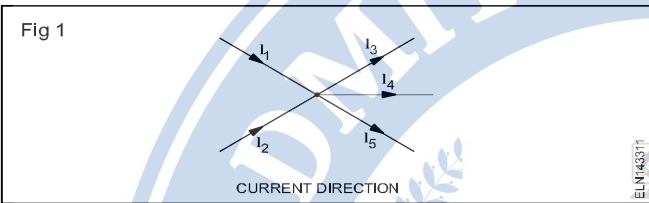

If all inflowing currents have positive signs and all outflowing currents have negative signs, then we can state that

$$I_1 + I_2 = I_3 + I_4 + I_5$$

$$+ I_1 + I_2 - I_3 - I_4 - I_5 = 0$$

In the above example the sum of all the currents flowing at the junction (node) is equal to zero.

$$\Sigma I = 0$$

$$I = I_1 + I_2 + I_3 + \dots$$

Example: Apply Kirchhoff's First Law to find the current shown in circuit.. (Fig 2)

Find current

$$I, I_1, I_2, I_3, I_4$$

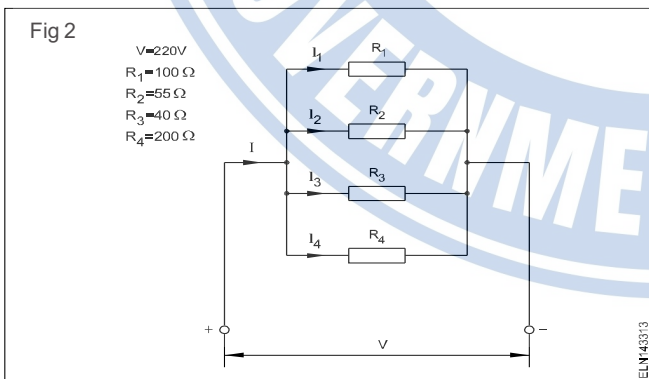

Solution

$$I_1 = \frac{V}{R_1} = \frac{220 \text{ V}}{100 \text{ ohms}} = 2.2\text{A}$$

$$I_2 = \frac{V}{R_2} = \frac{220 \text{ V}}{55 \text{ ohms}} = 4\text{A}$$

$$I_3 = \frac{V}{R_3} = \frac{220 \text{ V}}{40 \text{ ohms}} = 5.5\text{A}$$

$$I_4 = \frac{V}{R_4} = \frac{220 \text{ V}}{200 \text{ ohms}} = 1.1\text{A}$$

$$I = I_1 + I_2 + I_3 + I_4 = 2.2\text{A} + 4\text{A} + 5.5\text{A} + 1.1\text{A} = 12.8\text{A}$$

Checking the calculation

$$\frac{1}{R} = \frac{1}{R_1} + \frac{1}{R_2} + \frac{1}{R_3} + \frac{1}{R_4}$$

$$= \frac{1}{100} + \frac{1}{55} + \frac{1}{40} + \frac{1}{200}$$

$$= \frac{22 + 40 + 55 + 11}{2200} = \frac{128}{2200} = \frac{16}{275}$$

$$\frac{1}{R_{TOT}} = \frac{16}{275}$$

$$R_{TOT} = 17.19 \text{ ohms}$$

$$I = \frac{V}{R_{TOT}} = \frac{220\text{V}}{17.19 \text{ ohms}} = 12.798 \text{ A}$$

Kirchhoff's second law : In closed circuits, the applied terminal voltage V is equal to the sum of the voltage drops $V_1 + V_2$ and so forth. (Fig 3)

If all the generated voltages are taken as positive, and all the consumed voltages are taken as negative, then it can be stated that:

in each closed circuit the sum of all voltages is equal to zero.

$$\Sigma V = 0$$

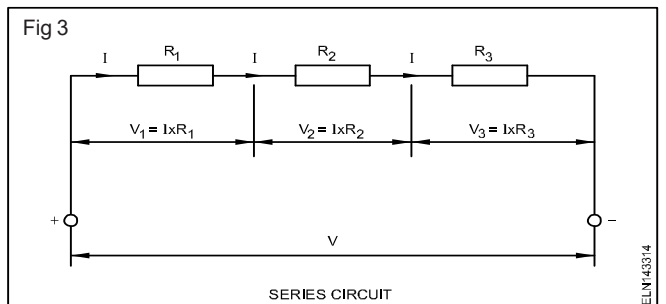

DC series and parallel circuits

Objectives: At the end of this lesson you shall be able to

- state the characteristics of series circuit and determine the current and voltage across each resistors
- determine the total voltage sources in series circuit
- state the relation between EMF potential difference and terminal voltage.

The series circuit

If more than one resistors are connected one by one like a chain and if the current has only one path is called as series circuit. It is possible to connect two incandescent lamps in the way shown in Fig 1. This connection is called a series connection, in which the same current flows in the two lamps.

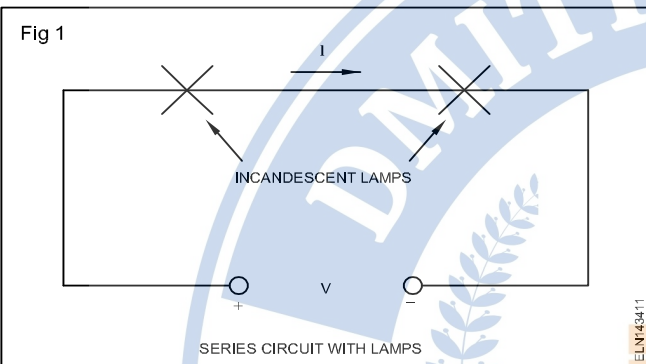

The lamps are replaced by resistors in Fig 2. Fig 2 (a) shows two resistors are connected in series between point A and point B. Fig 2(b) shows four resistors are in series. Of course, there can be any number of resistors in a series connection. Such connection provides only one path for the current to flow.

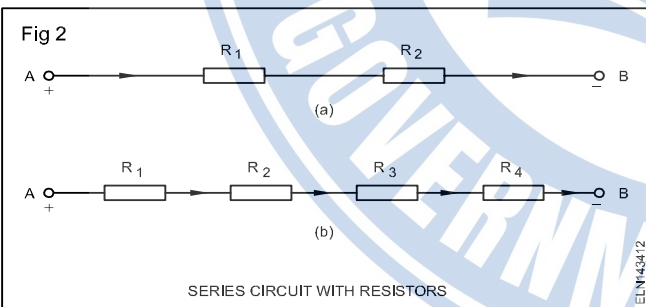

Current in series circuits

The current will be the same at any point of the series circuit. This can be verified by measuring the current in any two points of a given circuit as shown in Figs 3a and 3b. The ammeters will show the same reading.

The current relationship in a series circuit is

$$I = I_{R1} = I_{R2} = I_{R3} \dots (Refer Fig 3a \& 3b)$$

We can conclude that there is only one path for the current to flow in a series circuit. Hence, the current is the same throughout the circuit.

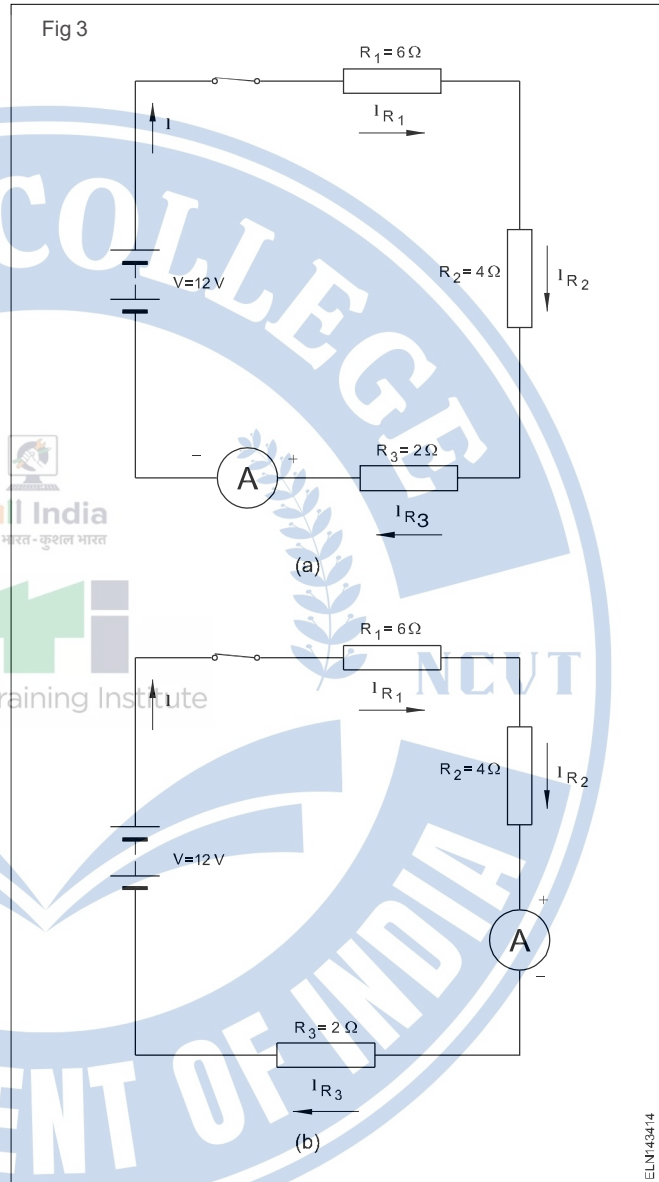

The total resistance in a series circuit is equal to the sum of the individual resistances around the series circuit. This statement can be written as

$$R = R_1 + R_2 + R_3 + \dots + R_n$$

where R is the total resistance

$R_1, R_2, R_3, \dots, R_n$ are the resistors connected in series.

When a circuit has more than one resistor of the same value in series, the total resistance is $R = r \times N$

where 'r' is the value of each resistor and N is the number of resistors in series.

Voltage in series circuits

In DC circuit voltage divides up across the load resistors, depending upon the value of the resistor so that the sum of the individual load voltages equals the source voltage.

As the source voltage divides/drops across the series resistance depending upon the value of the resistances

$$V = V_{R_1} + V_{R_2} + V_{R_3} + \dots + V_{R_H}$$

the total voltage of a series circuit must be measured across the voltage source, as shown in Fig 4.

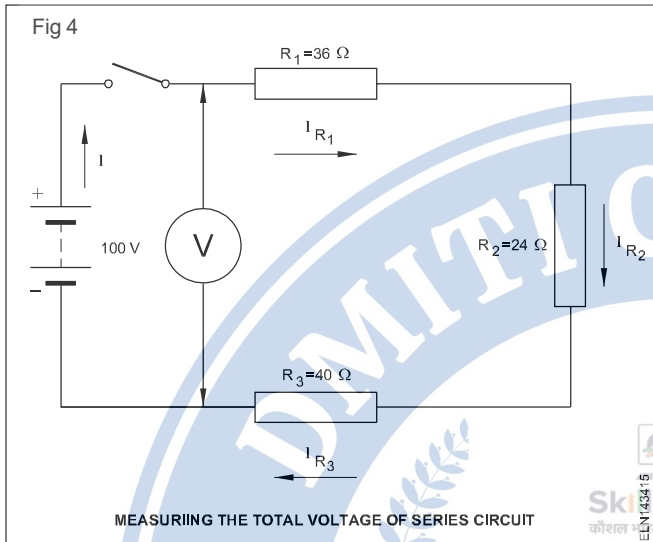

When Ohm's law is applied to the complete circuit having an applied voltage V , and total resistance R , we have the current in the circuit as

$$I = \frac{V}{R}$$

Application of Ohm's law to DC series circuits

Applying to Ohm's law to the series circuit, the relation between various currents could be stated as below

$$I = I_{R_1} = I_{R_2} = I_{R_3}$$

This could be stated as $\frac{V}{R} = \frac{V_{R_1}}{R_1} = \frac{V_{R_2}}{R_2} = \frac{V_{R_3}}{R_3}$

DC parallel circuit

Objectives: At the end of this lesson you shall be able to

- explain a parallel circuit
- determine the voltages in a parallel circuit
- determine the current in a parallel circuit
- determine the total resistances in a parallel circuit
- state the application of a parallel circuit.

In an electrical circuit, if the current has more than one paths and equal voltage in each branch is called parallel circuit.

It is possible to connect three incandescent lamps as shown in Fig 1. This connection is called parallel connection in which, the same source voltage is applied across all the three lamps.

You can use any of the above formulae to calculate current in a series circuit.

$$V = V_{R_1} + V_{R_2} + V_{R_3}$$

$$\text{i.e. } IR = R_1 I_{R_1} + R_2 I_{R_2} + R_3 I_{R_3}$$

and Total resistance $R = R_1 + R_2 + R_3$.

Use of series connection

- 1 Cells in torch light, car batteries, etc.
- 2 Cluster of mini-lamps used for decoration purposes.
- 3 Fuse in circuit.
- 4 Overload coil in motor starters.
- 5 Multiplier resistance of a voltmeter.

Definitions

Electromotive force (emf)

We have seen that the electromotive force (emf) of a cell is the open circuit voltage, and the potential difference (PD) is the voltage across the cell when it delivers a current. The potential difference is always less than the emf.

Potential difference

PD = emf – voltage drop in the cell

Potential difference can also be called by another term, the terminal voltage, as explained below.

Terminal voltage

It is the voltage available at the terminal of the source of supply. Its symbol is V_T . Its unit is also the volt. It is given by the emf minus the voltage drop in the source of supply,

$$\text{i.e. } V_T = \text{emf} - IR$$

where I is the current and R the resistance of the source.

Voltage drop (IR drop)

The voltage lost by resistance in a circuit is called the Voltage drop or IR drop.

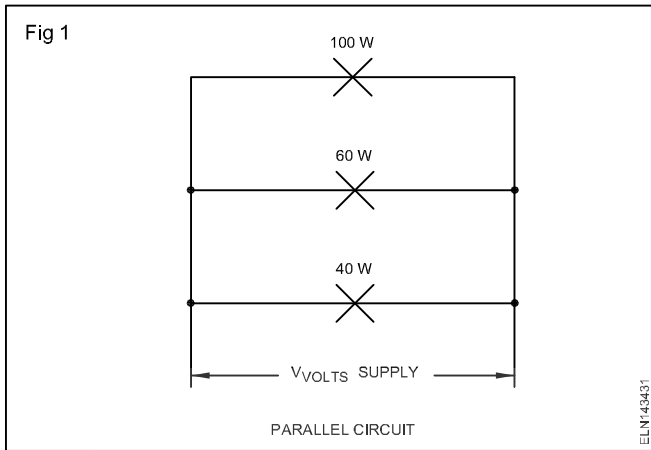

The total current I in the parallel circuit is the sum of the individual branch currents.

Mathematically it could be expressed as $I = I_1 + I_2 + I_3 + \dots + I_n$.

Resistance in parallel circuit

In a parallel circuit, individual branch resistances offer opposition to the current flow though the voltage across the branches will be same.

Let the total resistance in the parallel circuit be R ohms.

By the application of Ohm's law

we can write

$$R = \frac{V}{I} \text{ ohms or } I = \frac{V}{R} \text{ amps.}$$

where

R is the total resistance of the parallel circuit in ohms

V is the applied source voltage in volts, and

I is the total current in the parallel circuit in amperes.

We have also seen

$$I = I_1 + I_2 + I_3$$

$$\text{or } \frac{V}{R} = \frac{V}{R_1} + \frac{V}{R_2} + \frac{V}{R_3}$$

As V is the same throughout the equation and dividing the above equation by V , we can write

$$\frac{1}{R} = \frac{1}{R_1} + \frac{1}{R_2} + \frac{1}{R_3}$$

The above equation reveals that in a parallel circuit, the reciprocal of the total resistance is equal to the sum of the reciprocals of the individual branch resistances.

Applications of parallel circuits

The electric system used in homes consists of many parallel circuits.

An automobile electric system uses parallel circuits for lights, horn, motor, radio etc. Each of these devices operates independent of the others.

Individual television circuits are quite complex. However, the complex circuits are connected in parallel to the main power source. That is why the audio section of television receivers can still work when the video (picture) is inoperative.

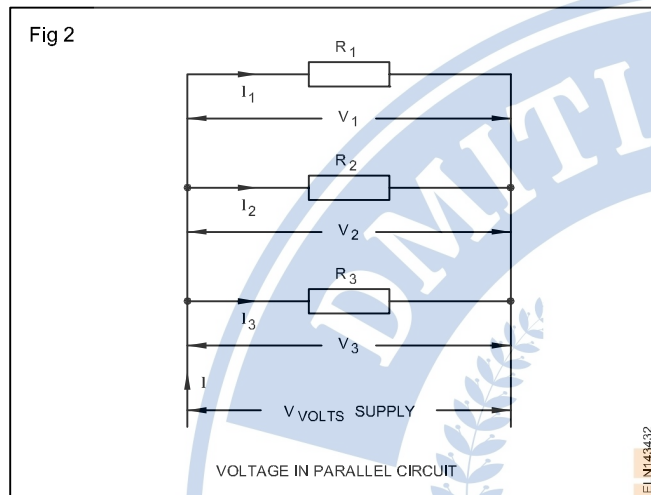

Mathematically it could be expressed as $V = V_1 = V_2 = V_3$.

Current in parallel circuit

Again referring to Fig 2 and applying Ohm's law, the individual branch currents in the parallel circuit could be determined.

$$\text{Current in resistor } R_1 = I_1 = \frac{V_1}{R_1} = \frac{V}{R_1}$$

$$\text{Current in resistor } R_2 = I_2 = \frac{V_2}{R_2} = \frac{V}{R_2}$$

$$\text{Current in resistor } R_3 = I_3 = \frac{V_3}{R_3} = \frac{V}{R_3}$$

$$\text{as } V_1 = V_2 = V_3.$$

Refer to Fig 2 in which the branch currents I_1 , I_2 and I_3 are shown to flow into resistance branches R_1 , R_2 and R_3 respectively.

Open and short circuit in series and parallel network

Objectives: At the end of this lesson you shall be able to

- state about short circuit in series circuit and its effect in series circuit
- state the effect of an open circuit in series circuit and its causes
- state the effect of shorts and open in parallel circuit.

Short circuits

A short circuit is a path of zero or very low resistance compared to the normal circuit resistance.

In a series circuit, short circuits may be partial or full (dead short) as shown in Fig 1 and Fig 2 respectively.

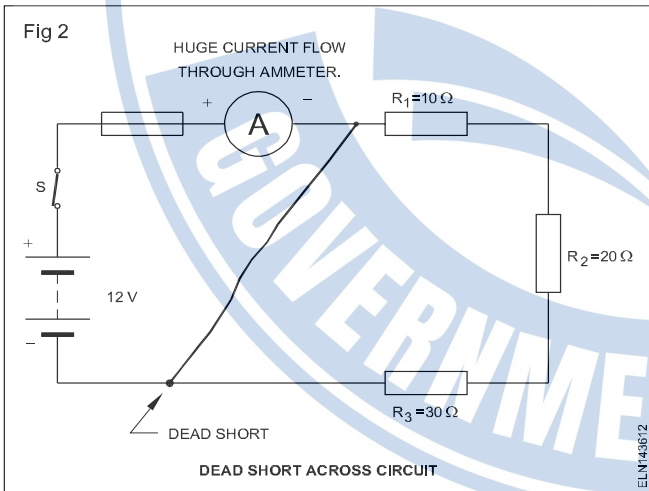
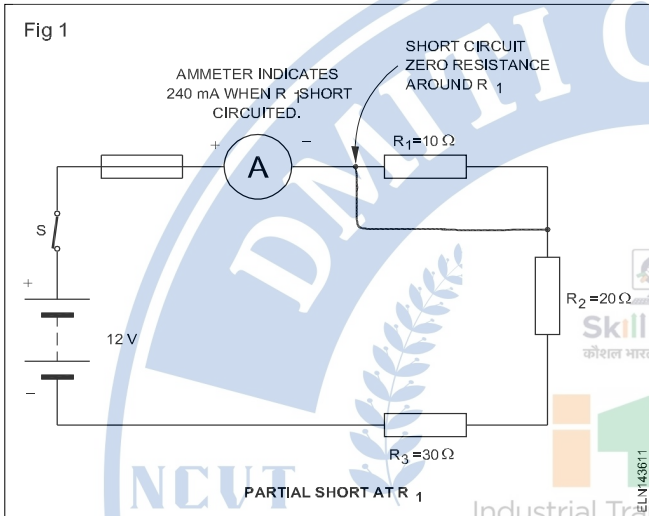

Short circuits cause an increase in current that may or damage the series circuit.

Effects due to short circuit

Excess current due to short circuit can damage the circuit components, power sources, or burn the insulation of connecting wires. Fire is also caused due to intense heat generated in the conductors.

Protection against dangers of short circuit

Dangers of short circuit can be prevented by means of fuses and circuit breakers in series with the circuit.

Detecting short circuit

When the ammeter in the circuit indicates excessive current then it indicates a short circuit in the circuit. The location of short in a circuit can be detected by connecting a voltmeter across each of the elements (resistors) and circuit source. If the voltmeter indicates zero volts or reduced voltage across the element, it is short circuited as shown in Fig 3.

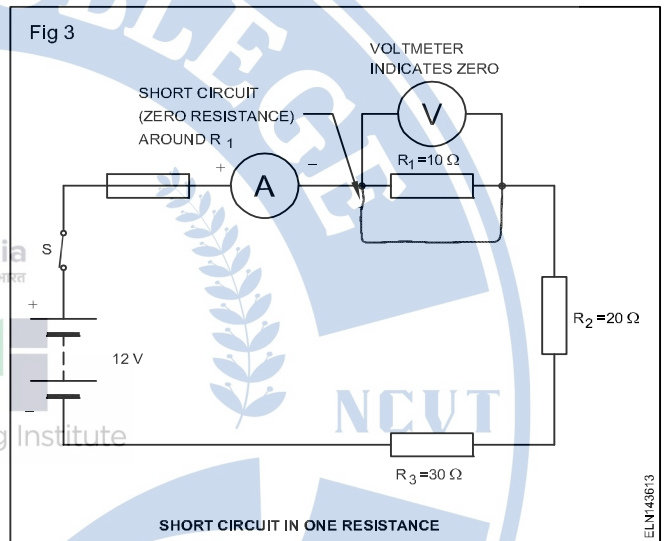

Open circuit in series circuit

An open circuit results whenever a circuit is broken or is incomplete, and there is no continuity in the circuit.

In a series circuit, open circuit means that there is no path for the current, and no current flows through the circuit. Any ammeter in the circuit will indicate no current as shown in Fig 4.

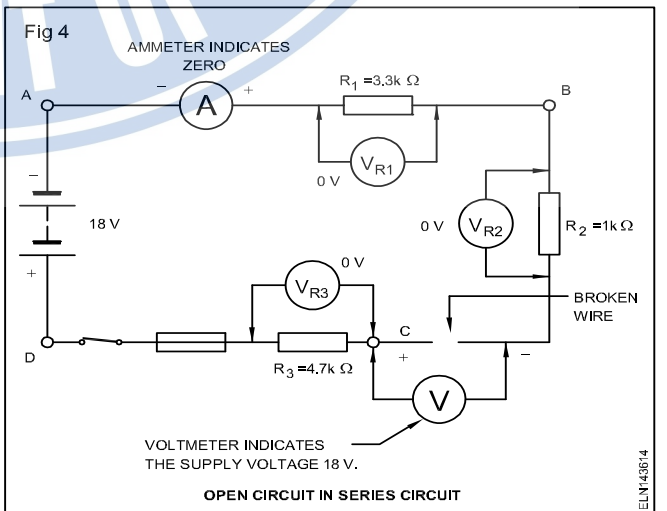

Causes for open circuit in series circuit

Open circuits, normally, happen due to improper contacts of switches, burnt out fuses, breakage in connection wires and burnt out resistors etc.

Effect of open in series circuit

- No current flows in the circuit.
- No device in the circuit will function.
- Total supply voltage/ source voltage appear across the open.

Determination the location of break in the circuit has occurred

Use a voltmeter on a range that can accommodate the supply voltage; connect it across each connecting wire in turn. If one of the wires is open as shown in Fig 4, the full supply voltage is indicated on the voltmeter. In the absence of a current, there is no voltage drop across any of the resistors. Therefore, the voltmeter must be reading full supply voltage across the open part of the circuit

Voltmeter reading

$$= 18 \text{ V} - V_{R_1} - V_{R_2} - V_{R_3}$$

$$= 18 \text{ V} - 0 \text{ V} - 0 \text{ V} - 0 \text{ V} = 18 \text{ V}.$$

If the circuit was open due to a defective resistor, as shown in Fig 5 (resistors usually open when they burn out), the voltmeter would indicate 18 V when connected across this resistor, R_2 .

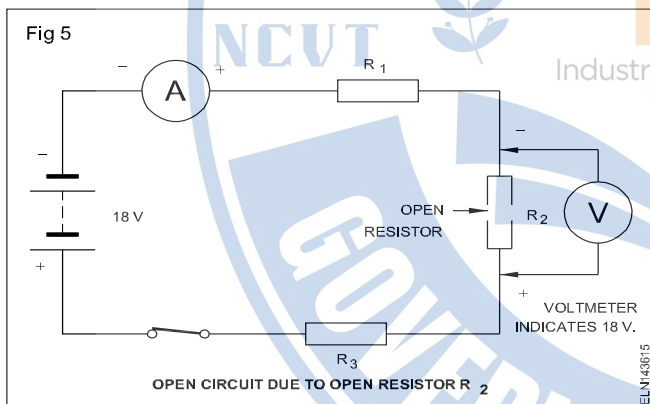

Alternatively, the open circuit may be found using an ohmmeter. With the voltage removed, the ohmmeter will show no continuity (infinite resistance), when connected across the broken wire or open resistor. (Fig 6)

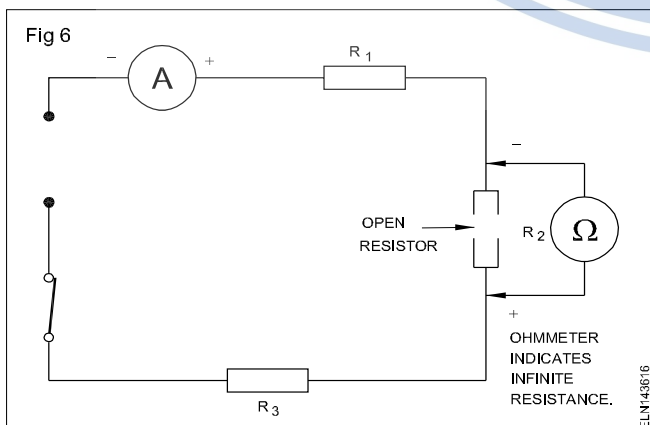

Shorts and opens in parallel circuits

The two possible defects that can occur in an electrical circuit they are:

- short circuit
- open circuit

Shorts in parallel circuit:

Fig 7 shows a parallel circuit with short between points 'a' and 'b'.

This causes reduction of circuit resistance almost to zero.

Therefore, the voltage drop across 'ab' will be almost zero (by Ohms law).

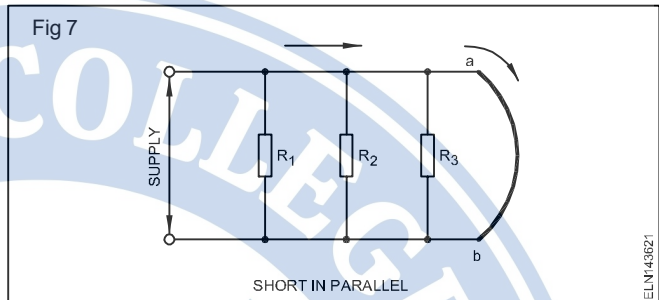

Thus current through the resistors R_1 , R_2 , R_3 will be negligible and not their normal current.

The result is that a very high current in the order of hundred times of the normal current will flow through the short circuit.

A short circuit exists when current can flow from the positive terminal of the power source through connecting wires and back to the negative terminal of the power source without going through any load. (Fig 8)

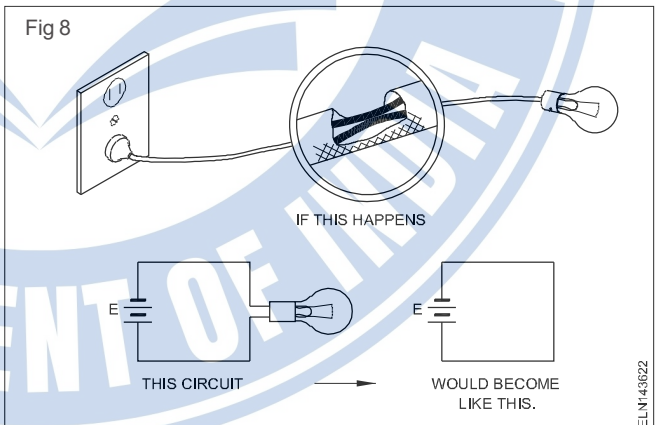

Short circuit may cause burning of the circuit elements like cables, switches etc.

To avoid burning of circuit components safety devices like 'fuse', circuit breakers etc. are used to open the circuit. (Figs 9a & 9b).

For a fuse to protect a parallel circuit, it should be placed in the circuit where the total current flows or else each branch must have a fuse. (Fig 10(a&b))

Fig 9

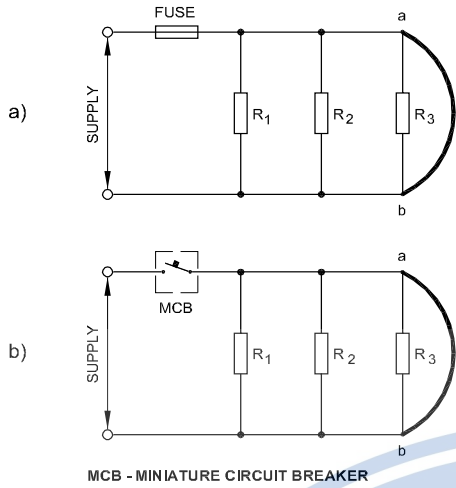

Opens in parallel circuit

An open in the common line at point A as shown in Fig 11 causes no current flow in that circuit whereas an open in the branch at point B causes no current flow only in that branch. (Fig 12)

However, the current in branches R_1 and R_3 will continue to flow so long as they are connected to the voltage source.

Full voltage of the source will be available at open circuit terminals. It is dangerous to meddle with the terminals which are open.

Fig 10

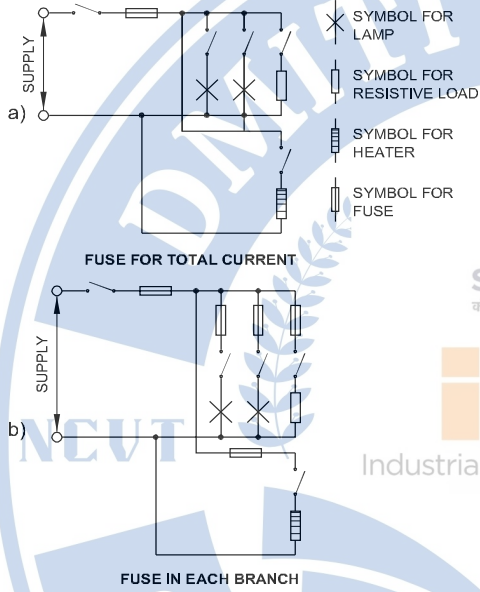

Fig 11

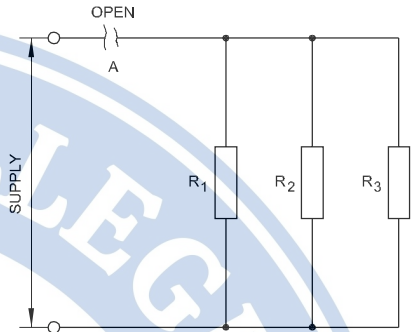
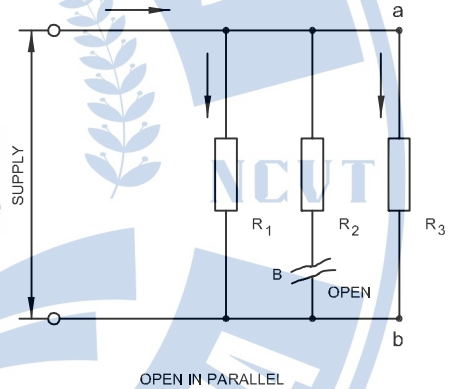

Fig 12



Laws of resistance and various types of resistors

Objectives: At the end of this lesson you shall be able to

- state the laws of resistance, compare resistances of different materials
- state the relationship between the resistance and diameter of a conductor
- calculate the resistance and diameter of a conductor from the given data (i.e. dimensions etc.)
- explain various types of resistors.

Laws of resistance: The resistance R offered by a conductor depends on the following factors.

- The resistance of the conductor varies directly with its length.
- The resistance of the conductor is inversely proportional to its cross-sectional area.
- The resistance of the conductor depends on the material with which it is made of.
- It also depends on the temperature of the conductor.

Ignoring the last factor for the time being, we can say that

$$R = \frac{\rho L}{a}$$

where 'ρ' (rho - Greek alphabet) - is a constant depending on the nature of the material of the conductor, and is known as its **specific resistance** or **resistivity**.

If the length is one metre and the area, 'a' = 1 m², then R = ρ.

Hence, specific resistance of a material may be defined as 'the resistance between the opposite faces of a metre cube of that material'. (or, sometimes, the unit cube is taken in centimetre cube of that material) (Fig 1).

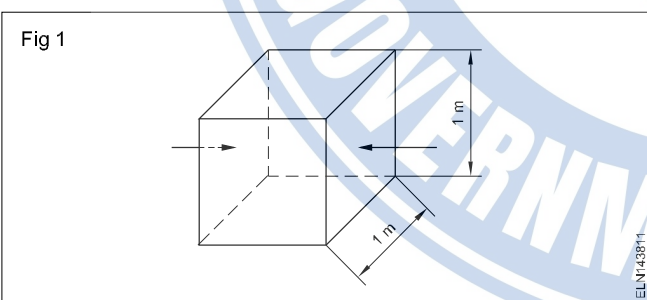

We have $\rho = \frac{aR}{L}$

In the SI system of units

$$\rho = \frac{a \text{ metre}^2 \times R \text{ ohm}}{L \text{ metre}}$$

$$= \frac{aR}{L} \text{ ohm - metre}$$

Hence the unit of specific resistance is ohm metre (Ωm).

Comparison of the resistance of different materials: Fig 2 gives some relative idea of the more important materials as conductors of electricity. All the conductors shown have the same cross-sectional area and the same amount of resistance. The silver wire is the longest while that of copper is slightly short and that of aluminium is shorter still. The silver wire is more than 5 times longer than the steel wire.

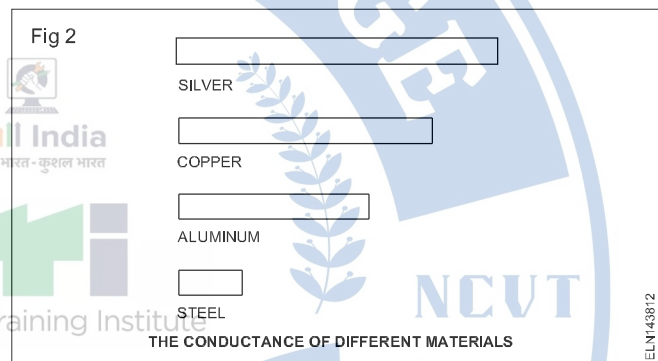

Since different metals have different conductance ratings, they must also have different resistance ratings. The resistance ratings of the different metals can be found by experimenting with a standard piece of each metal in an electric circuit. If you cut a piece of each of the more common metals to a standard size, and then connect the pieces to a battery, one at a time, you would find that different amounts of current would flow. (Fig 3)

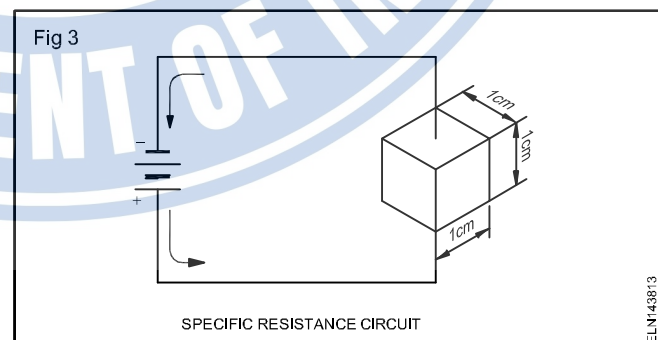

The bar graph (Fig 4) shows the resistance of some common metals as compared to copper. Silver is a better conductor than copper because it has less resistance. Nichrome has 60 times more resistance than copper, and copper will conduct 60 times as much current as Nichrome, if they were connected to the same battery, one at a time.

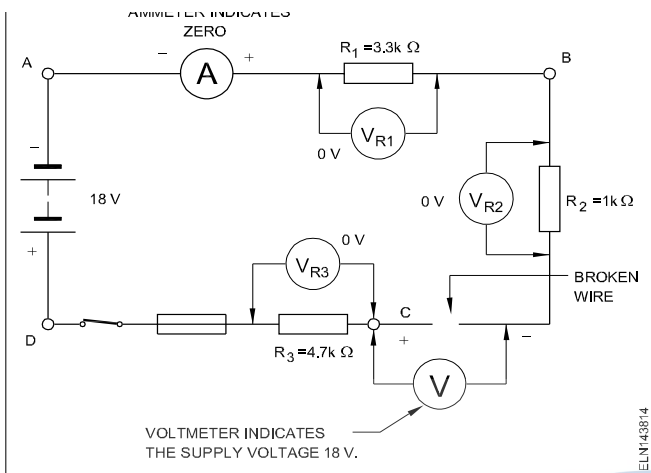

The other factor that influences the resistance is the nature of the material. Hence, we may now say that resistance of a wire

$$= \frac{\text{length}}{\text{area}} \times (\text{a constant}) \rho \text{ given material}$$

$$R(\text{ohms}) = \frac{L(\text{metres})}{\text{a metre}^2} \times \rho$$

So that $\rho = Ra \div L$ ohm/ meter

where ρ (greek letter, pronounced 'rho') represents the constant.

L is the length of the wire in metres

a is the area in square metres.

We can reduce all this into a simple statement: the larger the wire, the lower its resistance; the smaller cross sectional area of the wire, the higher its resistance.

We can summarize with the universal rule: the electrical resistance of any metallic conductor is inversely proportional to its cross-sectional area.

In general, we may, say that the resistance of a given length of a conductor is inversely proportional to its cross-sectional area (Fig 5)

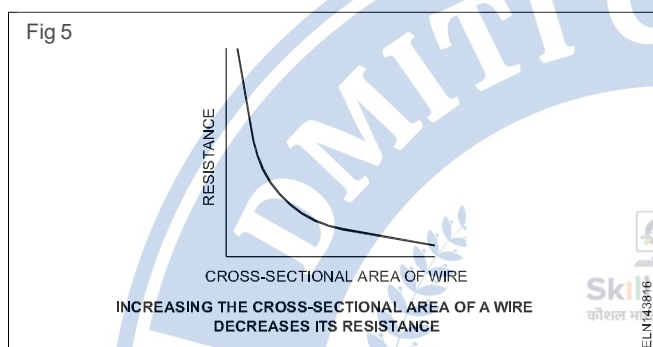

Resistors

Objective: At the end of this lesson you shall be able to

- explain the construction and characteristics of various types of resistors

Resistors: These are the most common passive component used in electrical and electronic circuits. A resistor is manufactured with a specific value of ohms (resistance). The purpose of using a resistor in circuit is either to limit the current to a specific value or to provide a desired voltage drop (IR). The power rating of resistors may be from fractional watts to hundreds of Watts.

There are five types of resistors

- 1 Wire-wound resistors
- 2 Carbon composition resistors
- 3 Metal film resistors
- 4 Carbon film resistors
- 5 Special resistors

1 Wire-wound resistors

Wire-wound resistors are manufactured by using resistance wire (nickel-chrome alloy called Nichrome) wrapped around an insulating core, such as ceramic porcelain, bakelite pressed paper etc. Fig 1, shows this type of resistor. Wire wound resistors are used for high current application. They are available in wattage ratings from one watt to 100 watts or more.

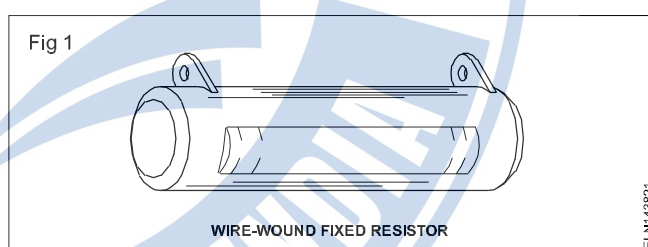

Fig 1 WIRE-WOUND FIXED RESISTOR

2 Carbon composition resistors

These are made of fine carbon or graphite mixed with powdered insulating material as a binder in the proportion needed for the desired resistance value. Fig 2 shows the construction of carbon composition resistor.

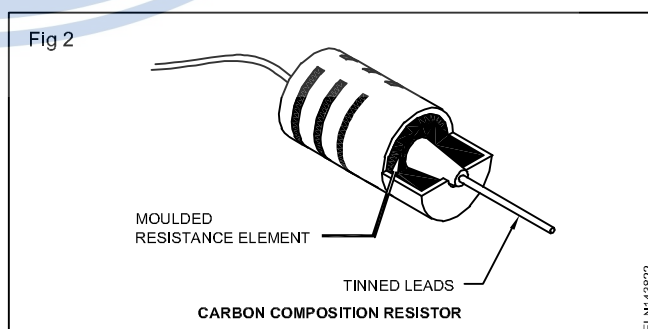
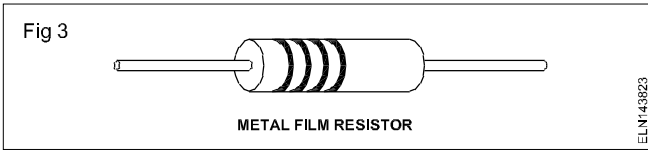

Fig 2 MOULDED RESISTANCE ELEMENT TINNED LEADS CARBON COMPOSITION RESISTOR

3 Metal film resistors (Fig 3)

Metal film resistors are manufactured by two processes. Thick film resistors are pasted with metal compound and powdered glass which are spread on the ceramic base and then backed (Fig 3).



Metal film resistors are available from 1 ohm to 10 MΩ, upto 1W.

4 Carbon film resistors (Fig 4)

In this type, a thin layer of carbon film is deposited on the ceramic base/tube. A spiral groove is cut over the surface to increase the length of the foil by a specialised process.

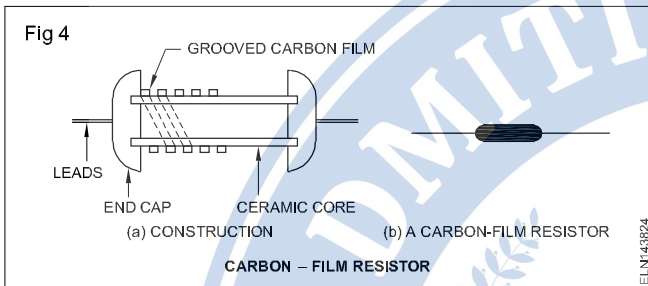

Carbon film resistors are available from 1 ohm to 10 meg ohm and up to 1 W and can work from 85°C to 155°C.

The resistors can also be classified with respect to their function as

- 1 Fixed resistors
- 2 Variable resistors

Fixed resistors : The fixed resistors is one in which the nominal value of resistance is fixed. These resistors are provided with pair of leads. (Fig 1 to 4)

Variable resistors (Fig 5) : Variable resistors are those whose values can be changed. Variable resistors includes those components in which the resistance value can be set at the different levels with the help of sliding contacts. These are known as potentiometer resistors or simply as potentiometers.

Resistance depends upon temperature, voltage, light : Special resistors are also produced whose resistance varies with temperature, voltage, and light.

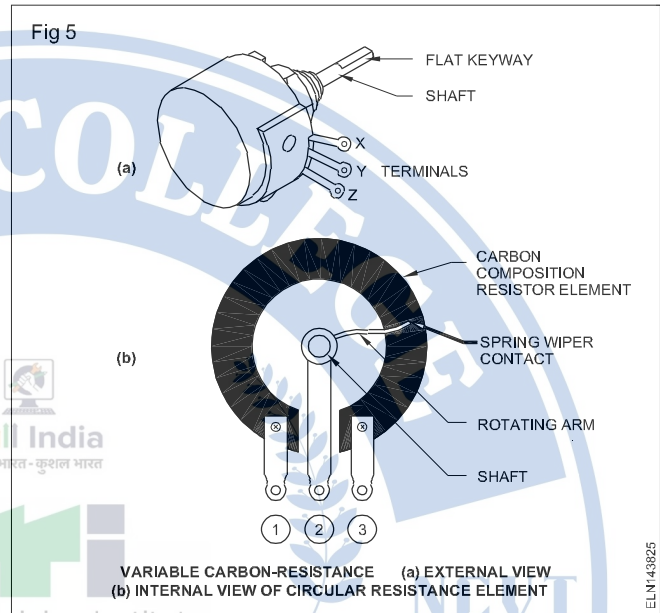

Marking codes for resistors

Objectives: At the end of this lesson you shall be able to

- interpret the coded marking of colours on the resistors
- interpret the letter and digit codes for resistance values
- state the tolerance value for resistors.

Resistance and tolerance value of colour coded resistors : Commercially, the value of resistance and tolerance value are marked over the resistors by colour codes (or) letter and digital codes.

The colour codes for indicating the values to two significant figure and tolerances are given in Table 1 as per IS 8186.

Table 1

Values to two significant figures and tolerances corresponding to colours

Colour	First Band/ Dot	Second Band/ Dot	Third Band/ Dot	Fourth Band/ Dot
	First Figure	Second Figure	Multiplier	Tolerance
Silver	—	—	10 ⁻²	± 10 %

Gold	—	—	10 ⁻¹	± 5 %
Black	—	0	1	—
Brown	1	1	10	± 1 %
Red	2	2	10 ²	± 2 %
Orange	3	3	10 ³	—
Yellow	4	4	10 ⁴	—
Green	5	5	10 ⁵	—
Blue	6	6	10 ⁶	—
Violet	7	7	10 ⁷	—
Grey	8	8	10 ⁸	—
White	9	9	10 ⁹	—
None	—	—	—	± 20 %

The two significant figures and tolerances colour coded resistors have 4 bands of colours coated on the body as in Fig.1.

The first band shall be the one nearest to one end of the component resistor. The second, third and four colour bands are shown in Fig 1.

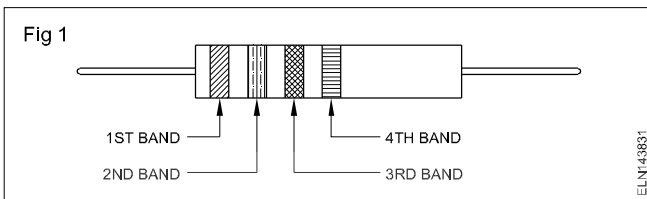

The first two colour bands indicate the first two digits in the numeric value of resistance. The third colour band indicates the multiplier. The first two digits are multiplied by the multiplier to obtain the actual resistance value. The fourth colour band indicates the tolerance in percentage.

Example

Resistance value : If the colour band on a resistor are in the order- Red, Green, Orange and Gold, then

First colour	Second colour	Third colour	Fourth colour
Red	Violet	Orange	Gold
2	7	1000(10 ³)	±5%

the value of the resistor is 27,000 ohms with +5% tolerance.

Tolerance value : The fourth band (tolerance) indicates the resistance range within which is the actual value falls. In the above example, the tolerance is ±5%. ±5% of 27000 is 1350 ohms. Therefore, the value of the resistor is any value between 25650 ohms and 28350 ohms. The resistors with lower value of tolerance (precision) are costlier than normal value of resistors.

Methods of measuring low and medium resistance

Objectives: At the end of this lesson you shall be able to

- state the different methods of measuring resistance
- describe the ammeter & voltmeter method.

Methods of measuring low resistance: The following three methods are used to measure low resistance:

- Voltmeter and ammeter method.
- Comparison of unknown with standard using potentiometer.
- Kelvin bridge
- Shunt type Ohmmeter

Ammeter and voltmeter method: This method, which is the simplest of all, is very commonly used for the measurement of low resistance.

In Fig 1, R_m is the resistance to be measured and V is a high resistance voltmeter of resistance R_v . A current from a steady direct current supply is passed through R in series with a suitable ammeter. Then assuming the current through the unknown resistance to be the same as that measured by the ammeter A , the formula is given as

$$R_m = \frac{\text{Voltmeter reading}}{\text{Ammeter reading}}$$

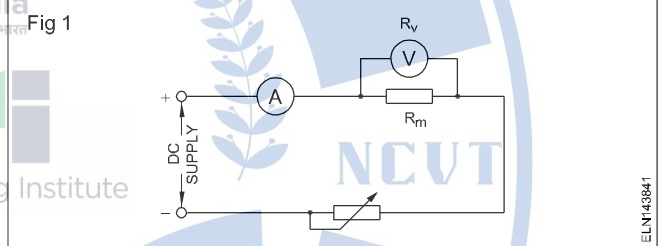

R_m = Measured value

Medium resistance: The following three methods are used to measure medium resistance.

- Series type Ohmmeter
- Voltmeter and ammeter method
- Wheatstone bridge method

Ohmmeter

Objectives: At the end of this lesson you shall be able to

- explain the principle, construction and use of a series type ohmmeter
- explain the principle, construction and use of a shunt type ohmmeter.

Measurement of resistances

Medium resistances could be measured by instruments like Kelvin's bridge, Wheatstone bridge, Slide wire bridge, Post Office box and Ohmmeter.

However, for measuring high resistances, instruments like megohmmeter or megger are used.

Ohmmeter

The ohmmeter is an instrument that is used for measuring resistance. There are two types of ohmmeters: the series ohmmeter is used for measuring medium resistances and the shunt type ohmmeter is used for measuring low and medium resistances. The ohmmeter in its basic form

consists of an internal dry cell, a PMMC meter movement and a current limiting resistance.

Before using an ohmmeter in a circuit, for resistance measurement, the current in the circuit must be switched off and also any electrolytic capacitor in the circuit should be discharged. Remember that the ohmmeter has its own source of supply.

Series type ohmmeter: construction

A series type ohmmeter shown in Fig 1 essentially consists of a PMMC (Permanent magnet moving coil) ('d' Arsonval) movement 'M', a limiting resistance R_1 and a battery 'E' and a pair of terminals A and B to which the unknown resistance ' R_x ' is to be connected. The shunt resistance R_2 connected in parallel to meter 'M' is used for adjusting the zero position of the pointer.

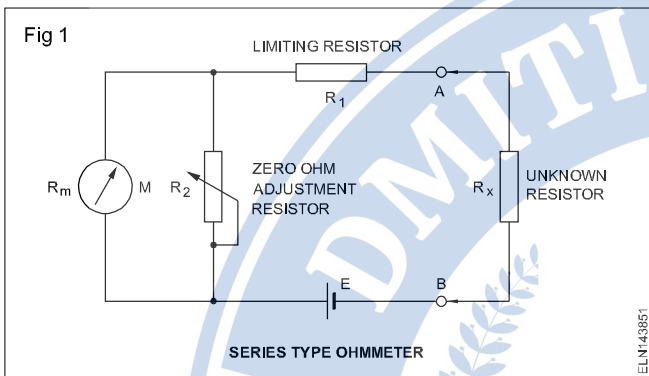

Working

When the terminals A and B are shorted (unknown resistor $R_x = \text{zero}$), maximum current flows in the circuit. The meter is made to read full scale current (I_{fsd}) by adjusting the shunt resistance R_2 . The full scale current position of the pointer is marked zero (0) ohm on the scale.

When the ohmmeter leads (A & B terminals) are open, no current flows through the meter movement. Therefore, the meter does not deflect and the pointer remains in the left hand side of the dial. The left side of the dial is marked as infinity (∞) resistance which means that there is infinite resistance (open circuit) between the test leads.

Intermediate marking may be placed in the dial (scale) by connecting different known values of R_x to the instrument terminals A and B.

The accuracy of the ohmmeter depends greatly upon the condition of the battery. The voltage of the internal battery may decrease gradually due to usage or storage time. As such the full scale current drops and the meter does not read zero when the terminals A and B are shorted.

The variable shunt resistor R_2 in Fig 1 provides an adjustment to counteract the effect of reduced battery voltage within certain limits. If the battery voltage falls below a certain value, adjusting R_2 may not bring the pointer to zero position, and hence, the battery should be replaced with a good one.

As shown in Fig 2, the meter scale will be marked zero ohms at the right end and infinity ohms at the left end.

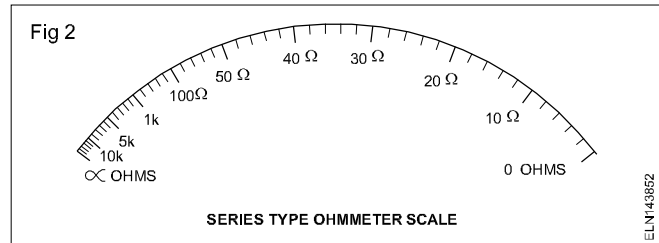

This ohmmeter has a non-linear scale because of the inverse relationship between resistance and current. This results in an expanded scale near the zero end and a crowded scale at the infinity end.

Shunt type ohmmeter

Fig 3 shows the circuit diagram of a shunt type ohmmeter. In this meter the battery 'E' is in series with the zero ohm, adjustment resistor R_1 and the PMMC meter movement. The unknown resistance R_x which is connected across the terminals A and B forms a parallel circuit with the meter. To avoid draining of the battery during storage, the switch S is of a spring-loaded, push-button type.

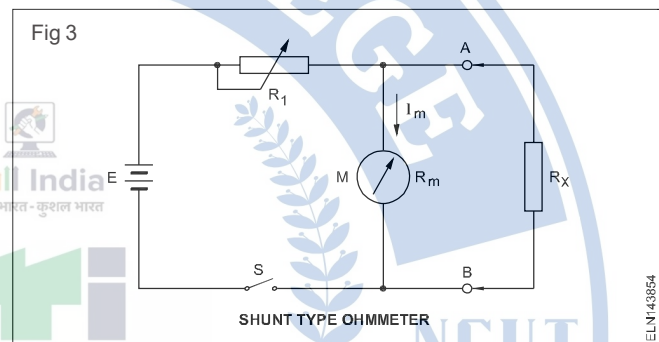

Working

When the terminals A and B are shorted (the unknown resistance $R_x = \text{zero ohm}$), the meter current is zero. On the other hand if the unknown resistance $R_x = \infty$ (keeping A and B open) the current flows only through the meter, and by proper selection of the value R_1 , the pointer can be made to read its full scale.

The shunt type ohmmeter, therefore, has the zero mark at the left hand side of the scale (no current) and the infinite mark at right hand side of the scale (full scale deflection current) as shown in Fig 4. When measuring the resistance of the intermediate values the current flow divides in a ratio inversely proportional to the meter resistance and the unknown resistance. Accordingly the pointer takes an intermediate position.

Use

This type of ohmmeter is particularly suitable for measuring low value resistors.

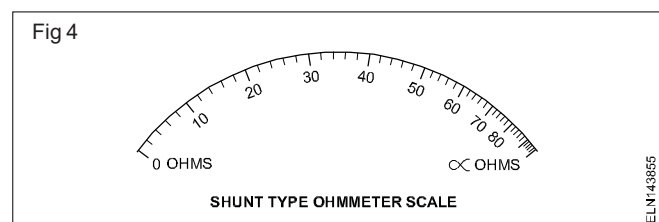

Wheatstone bridge - principle and its application

- Objectives:** At the end of this lesson you shall be able to
- state wheatstone bridge circuit, construction, function and uses.
 - determine the unknown resistance by the wheatstone bridge.

For determining the unknown resistance by Wheatstone Bridge

- The current flowing through the bridge connection should be zero.
- The values of the other three resistances should be precisely known.

How to find no current flows through the bridge connection?: An instrument, that can indicate the flow of even a few micro amperes (millionth of an ampere), called galvanometer, is used. There are galvanometers that give full scale deflection for 25 microamperes.

In the professional Wheatstone bridges, the galvanometer is provided with a parallel resistance and switch. The bridge connection is made only by pressing a push button. This enables the user to check a momentary deflection of the meter. In the case of excessive deflection, adjustment of the variable resistor is done. Final and precise adjustment of the variable resistance is made keeping the shunt resistor of the galvanometer open.

The three arms of the bridge are made of standard/precision resistors. The contact resistance is kept very very low to increase the accuracy of the measurement made by the Wheatstone bridge.

In short, the use of the galvanometer is to ensure that the current through the bridge connection is zero, i.e. both parallel branches have equipotential points connected by the bridge connector.

This arrangement is named after its inventor and is called the Wheatstone Bridge.

The Wheatstone Bridge is used for measurements in the range of about 1.0 ohm to 1.0 megohm. In Fig 1, resistors P, Q and S are internal to the instrument. R is the resistor of unknown value to be measured.

The instrument is adjusted until the ratio $\frac{Q}{P} = \frac{R}{S}$

This is indicated by a zero reading on the galvanometer with its switch in the closed position.

The resistors P and Q are called ratio arms. P and Q are varied in steps to give a range of values and the resistance value of 'S' is set by the decade resistance S.(Fig 2)

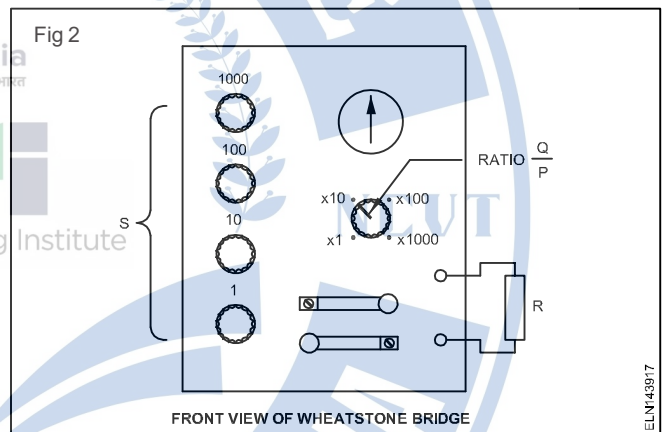
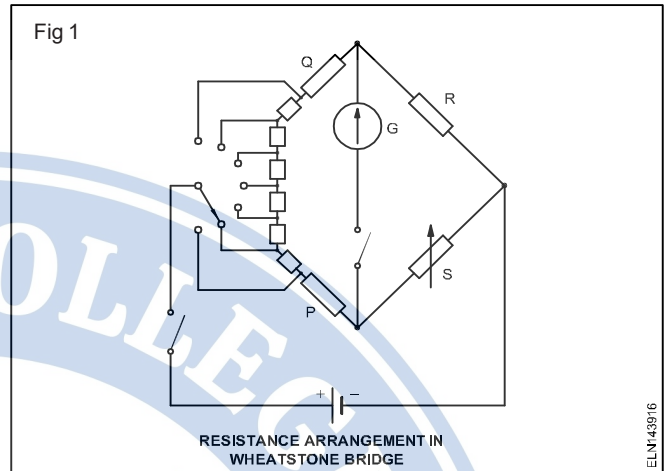

$R = \frac{Q}{P}$ multiplied by S.

The ratio $\frac{Q}{P}$ is arranged to be 1, 10, 100 or 1,000 for ease of calculation.

S is the variable resistance. Four decade resistances are connected in series. The value of S can be set in steps of one ohm from 1.0 ohm to 9999 ohms by suitably setting the four decade resistance units.

For example P = 10 ohm, Q = 100 ohm, S = 7ohm.

Then, $R_x = \frac{SXQ}{P} = \frac{7 \times 100}{10} = 70\Omega$

Effect of variation of temperature on resistance

Objectives: At the end of this lesson you shall be able to

- explain on what factors electrical resistance of a conductor depends
- state the temperature co-efficient of resistance.

The resistance of material largely depends on temperature and varies according to the material.

When resistance r is a constant depending on the nature of the material of the conductor and known as its specific resistance or resistivity. Dependency of resistance on temperature is explained in detail below:-

Effect of temperature on resistance: Actually, the relative values of resistance that were given earlier apply to the metals when they are at about room temperature. At higher or lower temperatures, the resistances of all materials change.

In most cases, when the temperature of a material goes up, its resistance goes up too. But with some other materials, increased temperature causes the resistance to go down.

The amount by which the resistance is affected by each degree of temperature change is called the temperature coefficient. And the words positive and negative are used to show whether the resistance goes up or down with the temperature.

When the resistance of the material goes up as temperature is increased, it has a positive temperature coefficient. It is appropriate in the case of pure metals such as silver, copper, aluminium, brass etc. (Fig 1)

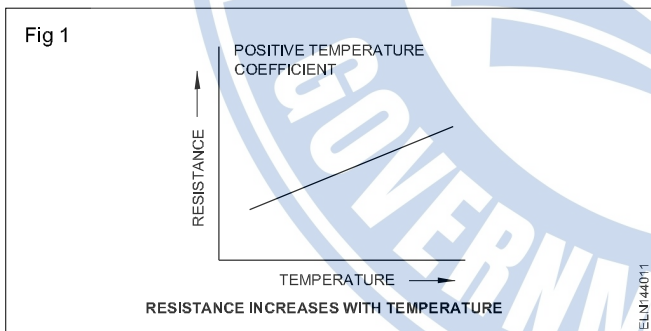

In the case of certain alloys such as eureka, manganin, etc. increase in resistance due to increase in temperature is relatively less and irregular.

When a material's resistance goes down as the temperature is increased, it has a negative temperature coefficient. (Fig 2)

This applies in the case of electrolytes, insulators such as paper, rubber, glass, mica etc. and partial conductors such as carbon.

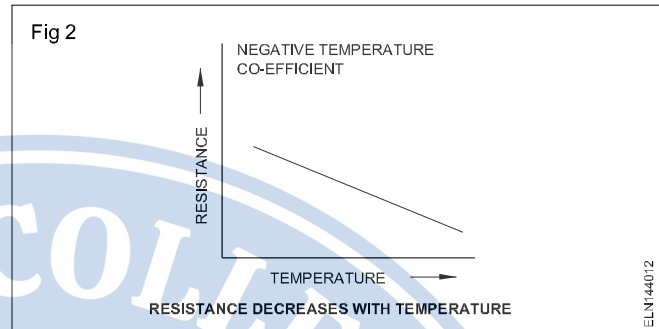

Temperature coefficient of resistance (α) of a conductor: Let a metallic conductor, having a resistance of R_0 at 0°C , be heated to $t^\circ\text{C}$ and let its resistance at this temperature be R_t . Then, considering normal ranges of temperature, it is found that the increase in resistance depends:

- directly on its initial resistance
- directly on the rise in temperature
- on the nature of the material of the conductor

$$\text{Hence } (R_t - R_0) = R_0 t \alpha \dots(i)$$

where α (alpha) is constant and is known as the temperature coefficient of resistance of the conductor.

Rearranging Eq.(i), we get

$$\alpha = \frac{R_t - R_0}{R_0 \times t} = \frac{\Delta R}{R_0 \times t}$$

$$\text{If } R_0 = 1\Omega, t = 1^\circ\text{C}, \text{ then } \alpha = \Delta R = R_t - R_0.$$

Hence, the temperature-coefficient of a material may be defined as: the change in resistance in ohm per $^\circ\text{C}$ rise in temperature.

$$\text{From Eq.(i), we find that } R_t = R_0(1 + \alpha t) \dots(ii)$$

In view of the dependence of α on the initial temperature, we may define the temperature coefficient of resistance at a given temperature as the change in resistance per ohm per degree centigrade change in temperature from the given temperature.

In case R_0 is not given, the relationship between the known resistance R_1 at $t_1^\circ\text{C}$ and the unknown resistance R_2 at $t_2^\circ\text{C}$ can be found as follows:

$$R_2 = R_0(1 + \alpha_0 t_2) \text{ and}$$

$$R_1 = R_0(1 + \alpha_0 t_1).$$

Therefore $\frac{R_2}{R_1} = \frac{1 + \alpha_0 t_2}{1 + \alpha_0 t_1}$

Resistivities and temperature coefficients

Material Metals-Alloys	Resistivity in ohm-metre at 20°C $\times 10^{-8}$	Temperature coefficient at 20°C $\times 10^{-4}$
Aluminium	2.8	40.3
Brass	6 – 8	20
Carbon	3000 –7000	–(5)
Constant or Eureka	49	(+0.160 –0.4)
Copper (annealed)	1.72	39.3
German silver	20.2	2.7
Iron	9.8	65
Manganin (84% Cu; 25% Mn; 4% Ni)	44 – 48	0.15
Mercury	95.8	8.9
Nichrome (60% Cu; 25% Fe; 15% Cr)	108.5	1.5
Nickel	7.8	54
Platinum	9 –15.5	36.7
Silver	1.64	38
Tungsten	5.5	47

Insulators

Insulators	Resistivity in ohm-metre at 20°C	Temperature coefficient at 20°C
Amber	5×10^{14}	
Bakelite	10^{10}	
Glass	$10^{10} - 10^{12}$	10^{12}
Mica	10^{15}	
Rubber	10^{16}	
Shellac	10^{14}	
Sulphur	10^{15}	

Example: The resistance of a field coil measures 55 ohms at 25°C and 65 ohms at 75°C. Find the temperature-coefficient of the conductor at 0°C.

$$R_t = R_0(1 + \alpha_0 t)$$

$$R_{25} = 55 = R_0(1 + 25\alpha_0) \quad \dots \text{Eqn.1}$$

$$R_{75} = 65 = R_0(1 + 75\alpha_0) \quad \dots \text{Eqn.2}$$

Dividing Eqn.2 by Eqn.1 we get

$$\frac{R_{75}}{R_{25}} = \frac{65}{55} = \frac{1 + 75\alpha_0}{1 + 25\alpha_0}$$

$$\frac{13}{11} = \frac{1 + 75\alpha_0}{1 + 25\alpha_0}$$

Cross multiplying we get

$$13[1 + 25\alpha_0] = 11[1 + 75\alpha_0]$$

$$13 + 325\alpha_0 = 11 + 825\alpha_0$$

$$13 - 11 = 825\alpha_0 - 325\alpha_0$$

$$2 = 500\alpha_0$$

$$\alpha_0 = \frac{2}{500} = 0.004 \text{ per } ^\circ\text{C}.$$

Series and parallel combination circuit

Objective: At the end of this lesson you shall be able to
• solve series-parallel circuit problems.

Formation of series parallel circuit

Apart from the series circuit and parallel circuits, the third type of circuit arrangement is the series-parallel circuit. In this circuit, there is at least one resistance connected in series and two connected in parallel. The two basic arrangements of the series-parallel circuit are shown here. In one, resistor R_1 and R_2 are connected in parallel and this parallel connection, in turn, is connected in series with resistance R_3 . (Fig 1)

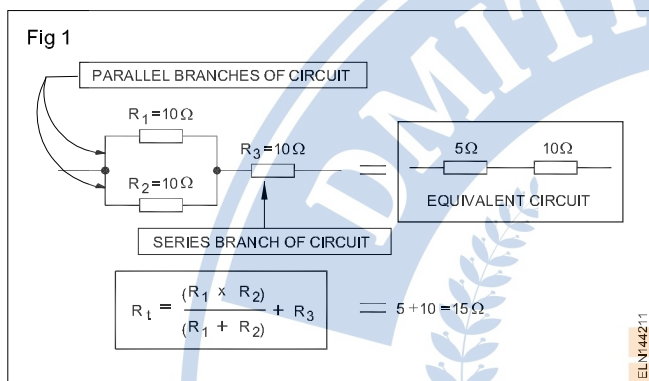

Thus, R_1 and R_2 form the parallel component, and R_3 the series component of a series-parallel circuit. The total resistance of any series-parallel circuit can be found by merely reducing it into a simple series circuit. For example, the parallel portion of R_1 and R_2 can be reduced to an equivalent 5-ohm resistor (two 10-ohm resistors in parallel).

Then it has an equivalent circuit of a 5-ohm resistor in series with the 10-ohm resistor (R_3), giving a total resistance of 15 ohms for the series-parallel combination.

A second basic series-parallel arrangement is shown in Fig 2 where basically it has two branches of a parallel circuit. However, in one of the branches it has two resistances in series R_2 and R_3 . To find the total resistance of this series-parallel circuit, first combine R_2 and R_3 into an equivalent 20-ohm resistance. The total resistance is then 20 ohms in parallel with 10 ohms, or 6.67 ohms.

Combination circuits

A series-parallel combination appears to be very complex. However, a simple solution is to break down the circuit into series/or parallel groups, and while solving problems, each

may be dealt with individually. Each group may be replaced by one resistance, having the value equal to the sum of all resistances.

Each parallel group may be replaced by one resistance value equivalent to the combined resistance of that group. Equivalent circuits are to be prepared for determining the current, voltage and resistance for each component.

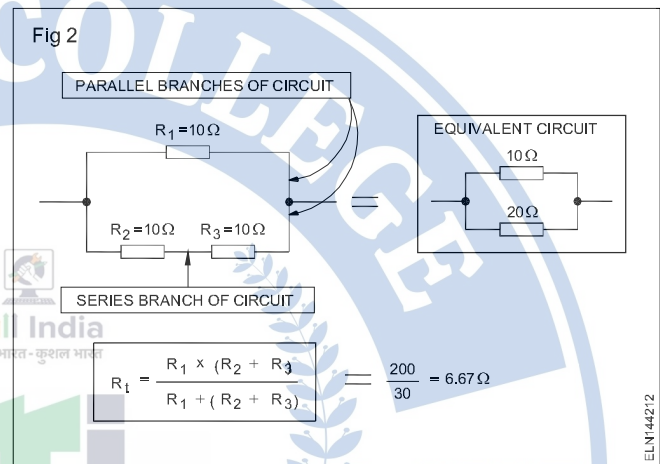

Application

Series-parallel circuits can be used to form a non-standard resistance value which is not available in the market and can be used in the voltage divider circuits.

Assignment

Determine the combined resistance of the circuit shown in Fig 3.

